

Cross Country Greenhouses

Traditional Series
Cottage & Cape Cod
Free Standing

GREENHOUSE INSTRUCTIONS



Manufactured for:



Contents

Foreword	2
User Notes	2
List of Drawings	3
Traditional Straight Series Component List	4
Foundations	5
New Pressure Treated Wood	6
Assembly of the Aluminum Frame	
A. Back Gable-End Assembly	7
B. Front Gable-End Assembly With Door	10
C. Sidewall Assembly	14
Aluminum Frame Installation	
1. Side Wall	15
2. Side Wall To Back Gable End	15
3. Side Wall To Front Gable End	15
4. Bolt Side Wall to Front and Back	15
5. Ridge	16
6. Glass bar With Sliders (#1 or #2 or more)	16
7. Vent Frame Angle	16
8. Glass bars	16
9. Fastening The Base/Sill To The Foundation	16
Truss Assembly Installation	20
Perlin Installation	23
10. Taping Glass bars with Foam	28
<i>Side Vents, Intake Shutter, Polycarbonate Roof and Exhaust Fan Installation (if necessary).</i>	<i>See Appendices B through F</i>
Glass and Cap Installation	
General Information	29
9. Side Glass	30
10. Roof Glass	31
11. End Walls Glass	32
12. Sealing The Greenhouse	33
Door And Vent Installation	
13. Door Installation	34
14. Vent Assembly	36
15. Vent Installation	36

Foreword

Your Traditional greenhouse is designed and constructed to the highest engineering standards and provides structural strength and maintenance-free service for year-round gardening pleasure.

The Traditional greenhouse must be built upon a firm, level surface. The greenhouse foundation or sill can be made from pre-treated timbers, concrete or bricks. Whatever your choice of material, the base must be square and level.

When selecting a site for your greenhouse, keep in mind that a flat, level site is essential so that the greenhouse can be easily installed and the complete structure is stable and secure. If possible, choose a site with proper water drainage.

Locating the greenhouse in a north-south position is most suitable for raising summer and autumn crops since the sun's rays will be on the greenhouse from daybreak until sunset. An east-west position is ideal for early spring and winter crops since the winter months, with shorter daylight hours, still allow six hours of light exposure to the greenhouse.

Try to locate your greenhouse for easy access, especially to the necessary power and water that is required for greenhouse gardening.

Please watch the enclosed video and follow the steps in this manual for your greenhouse installation. *Remember, if all else fails, read the instructions.*

User Notes

The Traditional greenhouse structure has been designed to withstand extreme weather conditions such as high winds and accumulated snowfall. Hanging baskets and sidewall shelving can also be attached to its sturdy frame. The greenhouse design also makes it possible to add extra sections at a later date.

Once a year the greenhouse needs to be completely washed inside and out. You should do this task when your greenhouse contains the least number of plants, generally just before the garden plants are brought in for wintering over. A recommended cleaning solution is a mixture of hot water with a disinfectant such as Lysol or Pinesol. *(Warm soapy water is to be used if there is a polycarbonate roof).* Any benches, shelving, plastic trays, pots and baskets should also be cleaned thoroughly. *Prevention is the best known method for controlling pests and diseases in the greenhouse.*

PLEASE NOTE: *The Illustrations found in this manual may not be specific to your greenhouse, however the detail of aluminum shapes are all consistent. The user notes are a generic instruction for all Traditional Series Greenhouses – assembly instructions are common, only the sizes number of pieces and sizes vary.*

List of Drawings

Foundation Styles	5
Back Gable End Line Drawing – <i>Details 1-5</i>	7
Back Gable End Inside View Picture	8
Front Gable End (With Door) Inside View Line Drawing – <i>Details 1-7</i>	10
Front Gable End (With Door) Inside View Picture	11
Assembly Outline Steps 1-5	17 - 19
Steps 6-9	24 - 27
Door Installation	35
Vent Assembly - Exploded View	38
Vent Detail	37
Vent Opener	Appendix A
Exhaust Fan	Appendix B
Side Vent	Appendix C
Glass Louvre	Appendix D
Diagonal Brace	Appendix E
Polycarbonate Roof Panels Installation	Appendix F
Intake Shutter	Appendix G
Cedar Bench	Appendix H
Greenhouse Bench	Appendix I
Roof Vent Screen	Appendix J
Side Vent Screen	Appendix K
Wire Shelving	Appendix L

Traditional Component List

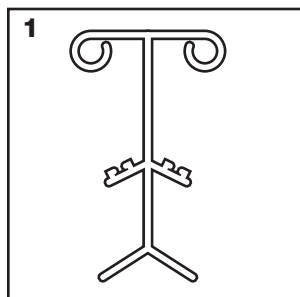

Ridge

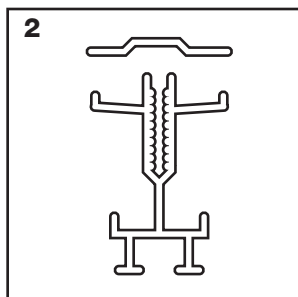

Glass Cap & Glass Bar

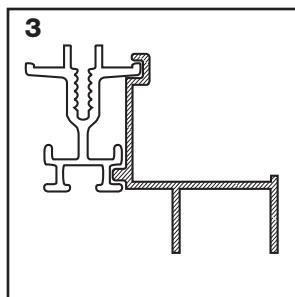

End Rafter

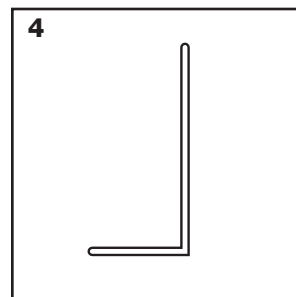

Ventframe Bottom

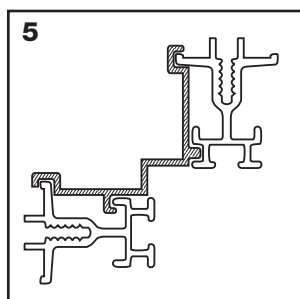

Corner Post

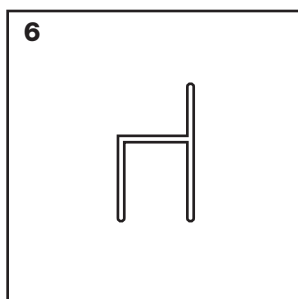

Plastic h came

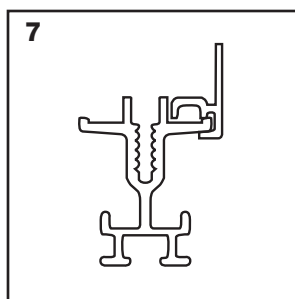

Vent Frame Sides

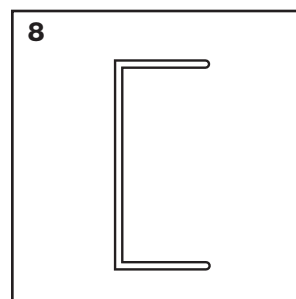

Perlin (if required)

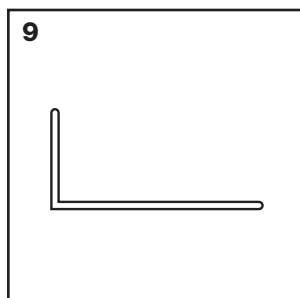

Base / Sill

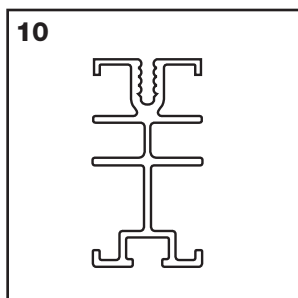

Door Frame

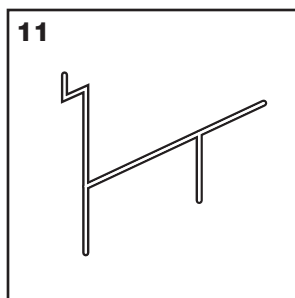

Gutter

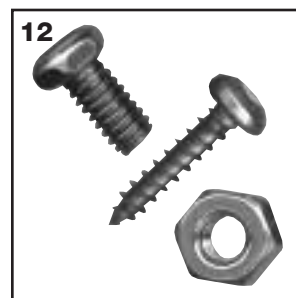

Screws and Bolts

Tools

- #2 Square head screw driver
- Measuring tape
- Level to check foundation
- 3/16" concrete bit (concrete foundation)
- 9/64" aluminum bit
- 15/64" aluminum bit fastening perlin to trusses (larger greenhouses)
- 7/16" wrench
- Razor blade cutter
- Caulking gun
- Ladder
- Hammer

Optionals

- Automatic Opener
- Circulating Fan
- Max/Min thermometer
- Benches
- Eyebolts
- Motorized Intake Shutter
- Exhaust Fan
- Thermostat
- Heater

Foundations

Check your local building codes for foundation requirements in your area.

CONCRETE FOUNDATIONS

When you prepare the concrete foundation, the size should be built to the exact greenhouse's outside dimensions.

PRE-TREATED WOOD FOUNDATIONS

A greenhouse that is approximately 100 sq. ft. (9.3 m²) can be fastened to a 4" x 4" pre-treated wood timber foundation. For larger greenhouses, a 6" x 6" wood timber foundation is recommended. These timbers are placed on a 4" (10 cm) deep and 8" (20 cm) wide gravel bed. Wood timbers can be stacked to increase the height of the greenhouse. *One advantage of the wood foundation is that it is not classified as a permanent structure. Therefore, if you move, the greenhouse can be dismantled and moved to another location.*

A SQUARE AND LEVEL FOUNDATION

Check the width and length of the foundation's outside dimensions. Then, square the foundation by measuring diagonally from opposite corners in the form of an "X". Next, use a long carpenter's level to check and adjust the foundation until it is level. Finally, measure where the door will be placed (in most cases it is 34¹/₂" wide). Mark these measurements on your foundation.

Foundation Styles

IMPORTANT NOTE: If pressure treated timbers are used, a 10mm polyethylene barrier must be used between the wood and the aluminum (see page 6)

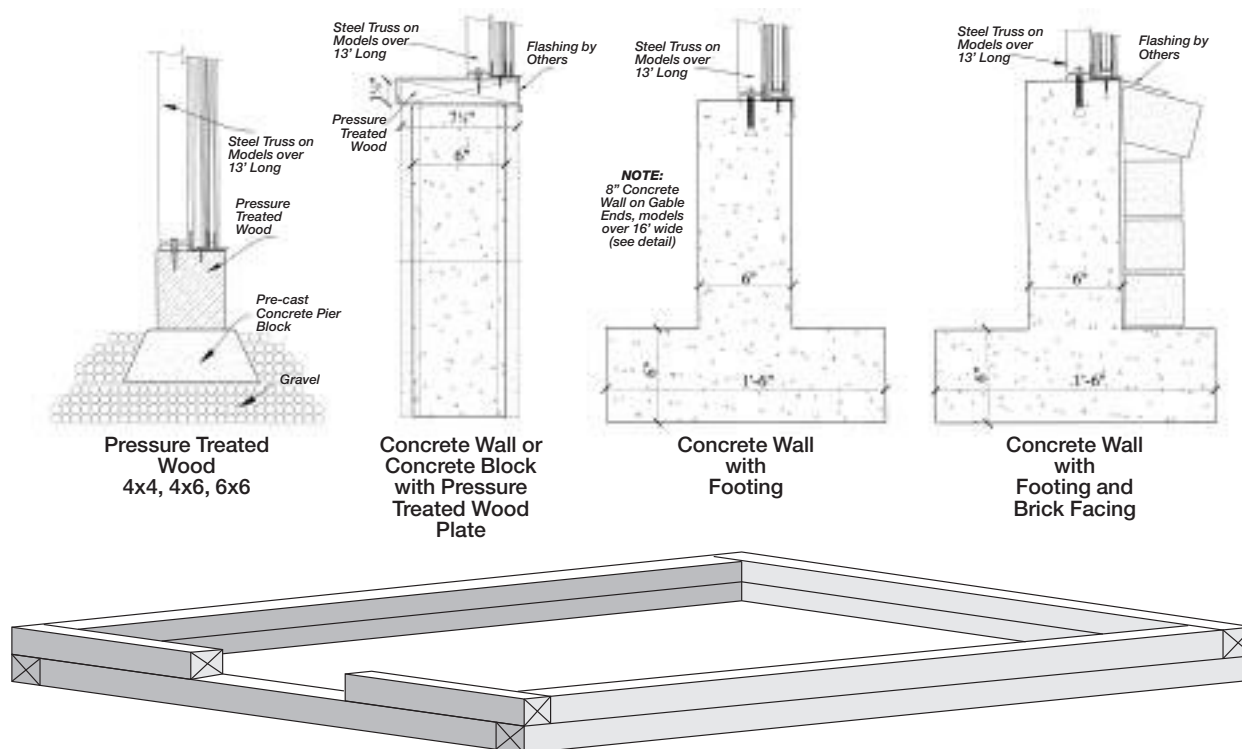

PRE-TREATED WOOD FOUNDATION

'New' Pressure Treated Wood

WHAT IS NEW ABOUT PRESSURE TREATED WOOD?

As of January 2005, the chemicals used in pressure treated wood have been changed. Previous wood was treated with arsenic. However due to the potential long term health hazards this has been discontinued. New pressure treated wood is treated with copper.

The copper in the 'new' wood will be CORROSIVE TO ALUMINUM as well as other metals.

What are 'Greenhouse Friendly' solutions to the new pressure treated wood?

- 1 If you are using the new pressure treated wood, you must place a barrier between the wood and your aluminum frame. Popular barriers include 10 mil thick plastic sheeting, steel weather flashing, a rubber or foam weather membrane, or a row of weather resistant non-treated wood such as cedar or hemlock.
- 2 Other weather resistant non-treated woods are popular alternatives to pressure treated wood. These contain no harmful chemicals and will outlast pressure treated wood. Cedar timbers are a popular choice for greenhouse foundations.
- 3 Concrete foundations have always been suitable foundation alternatives for greenhouses. They can vary from poured concrete slabs, poured concrete perimeter walls to concrete block walls. Although these are usually more costly than wood alternatives, they have the benefit of lasting a lifetime. As they are usually considered a permanent foundation, it is important to check with your building codes to determine what you are able to build.

If you have any questions about using the 'New' pressure treated wood in conjunction with our aluminum greenhouses, please contact our office at 1-888-391-4433.

Back Gable End Line Drawing Assembly Procedure

1



Base

2

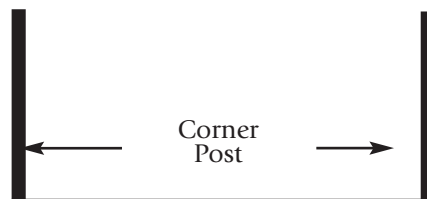

Corner Post

3

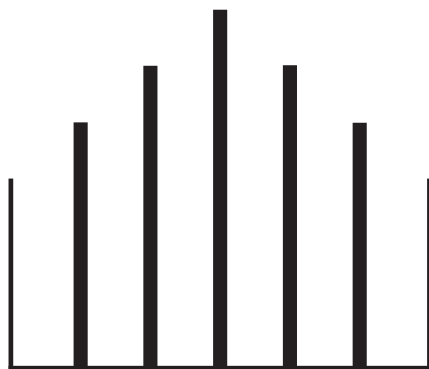

Glass Bars

4

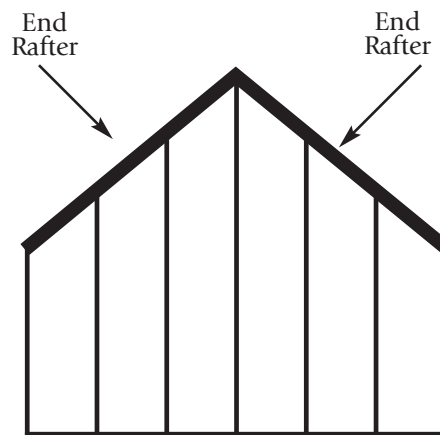

End Rafter

End Rafter

5

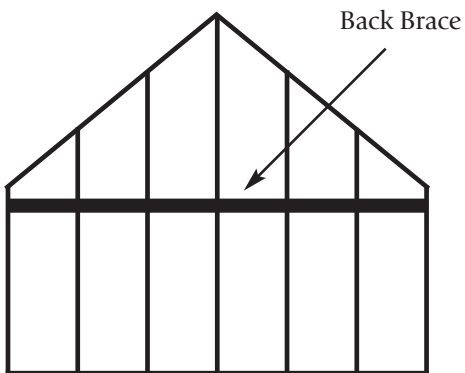

Back Brace

6

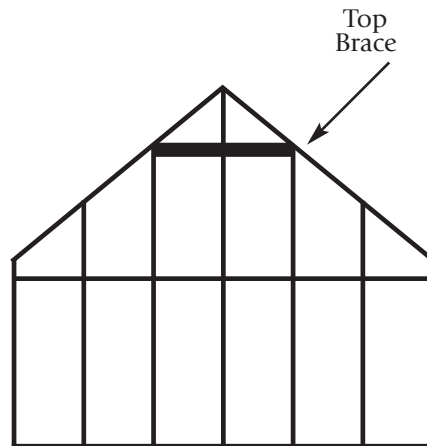

Top Brace

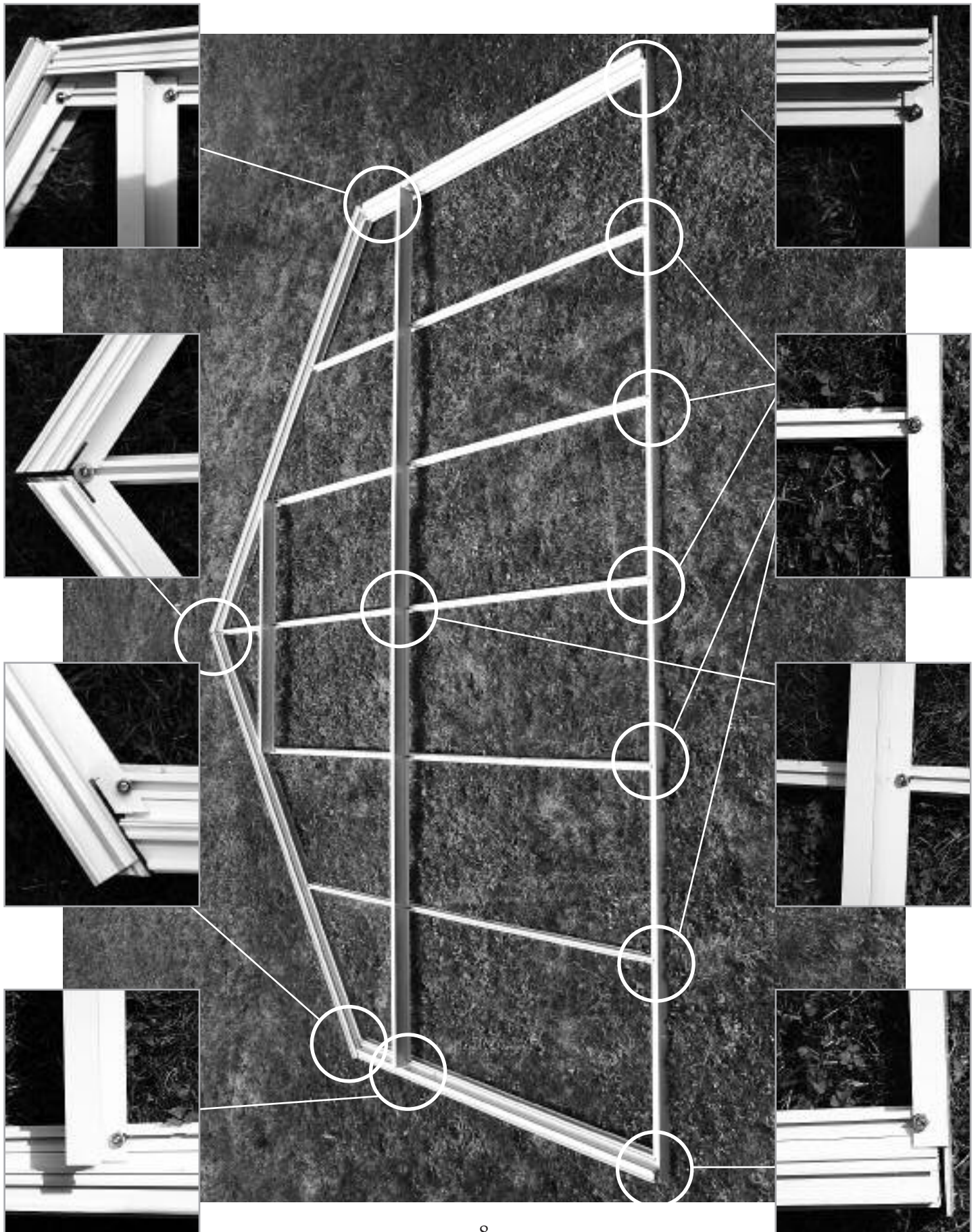

Back Gable End Assembly

Lay out the back pieces into the shape of an end wall. All glass bars have a track for the bolts. The track must face up towards you when you assemble the gable ends. Slide the bolts in to the ends or use the notches that are punched out in the glass bars. Refer to the line/detail drawings when assembling. (the sketches/drawings/pictures are viewed from inside the greenhouse).

1. The 1" x 2" angle / base (Page 4, #9) laying on the ground should have the 1" side (with the slot punches out) facing up (Page 7, #1). (See Pic A.)
2. Bolt the corner post (Page 4, #5) onto the base angle (Page 7, #2). (See Pic B.)
3. Bolt on all the end bars (Page 4, #2) to the base. Make sure that the longest bar is in the center of the back wall (Page 7, #3) and the angle of the other bars are sloping downward.
4. End Rafter (Page 4, #3). When fastening end rafters to the cornerpost, leave a 1/8" space for gutters. (Page 7, #4). Pic **C**.
5. Bolt the angle/channel cross brace approx. 60" from the base with 1/4" x 1/2" bolts (Page 7, #5). Pic **D**.
6. The short angle/channel cross brace is bolted on at the top (Page 7, #6).

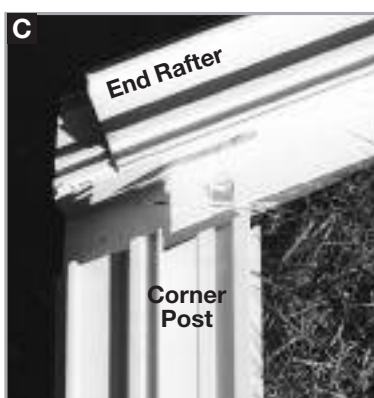
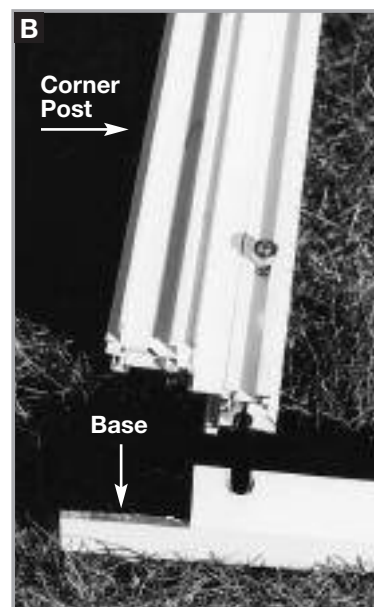

Front Gable End (with door) Line Drawing Assembly Procedure

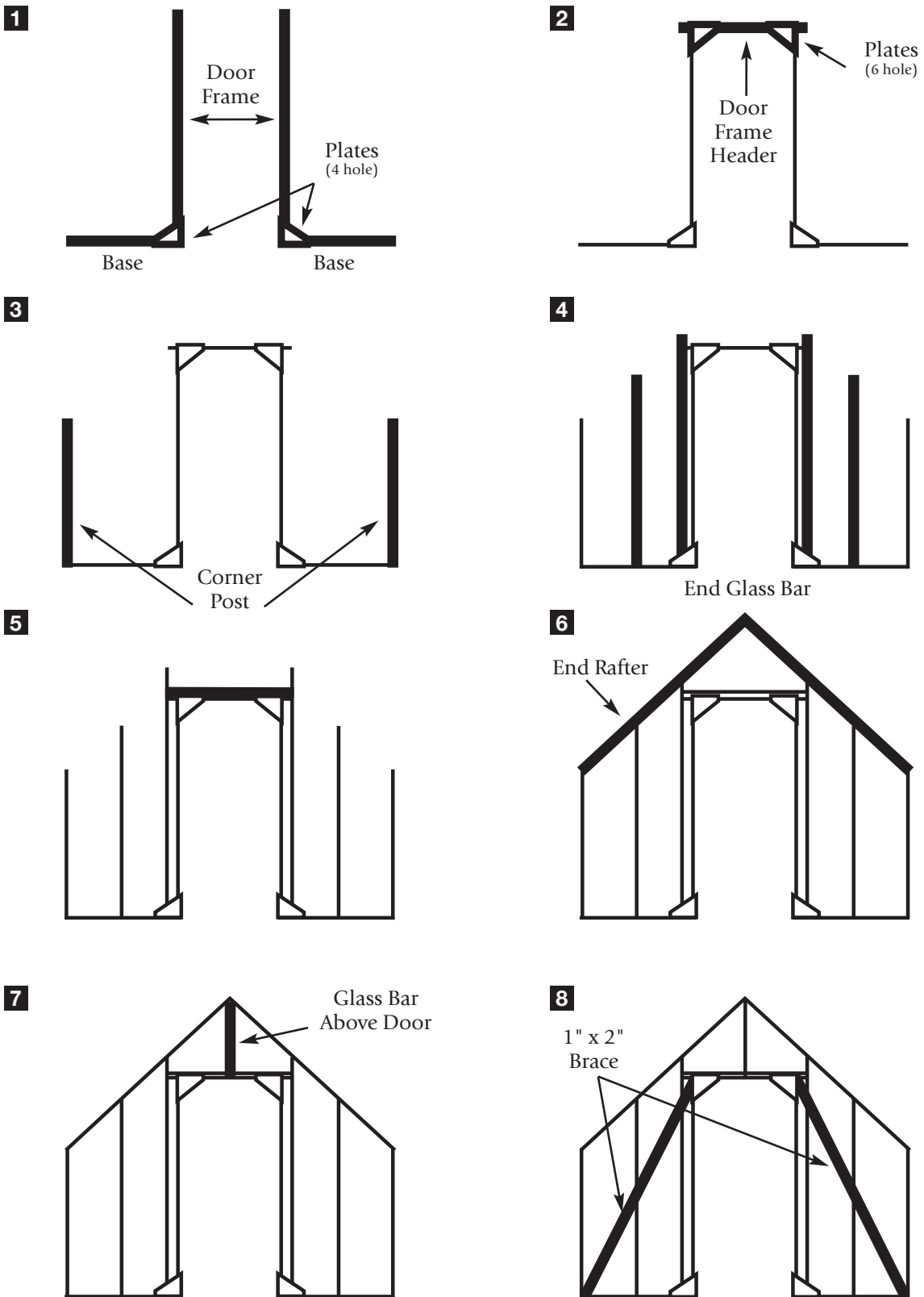

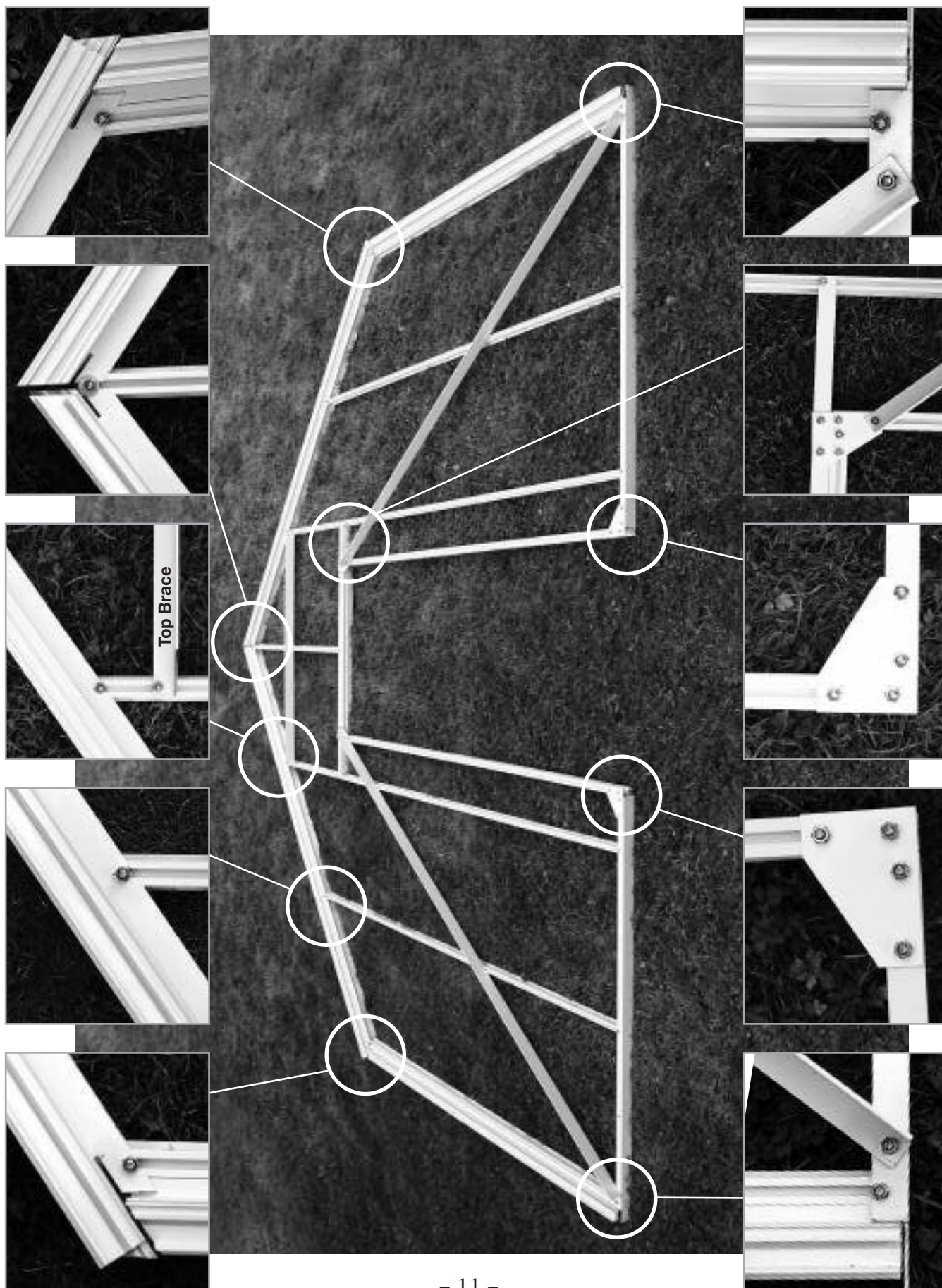

Front Gable End Assembly

Lay out the front pieces into the shape of an end wall. The doorframe and all glass bars have a track for the bolts. The track must face up towards you when you assemble the gable ends. Slide the bolts in to the ends or use the notches that are punched out in the glass bars. Refer to the line/detail drawings when assembling. (*the sketches/drawings/pictures are viewed from inside the greenhouse*).

1. Bolt the bottom plates (4 holes) to the base/sill and the doorframe sides using 1/4" x 1/2" stainless steel bolts (See Pic **A**). Before tightening the bolts, be sure that it is square (Page 10, #1). (If you ordered a greenhouse with a door drop, measure from the bottom of the doorframe to the underside of the base according to the specified distance.)

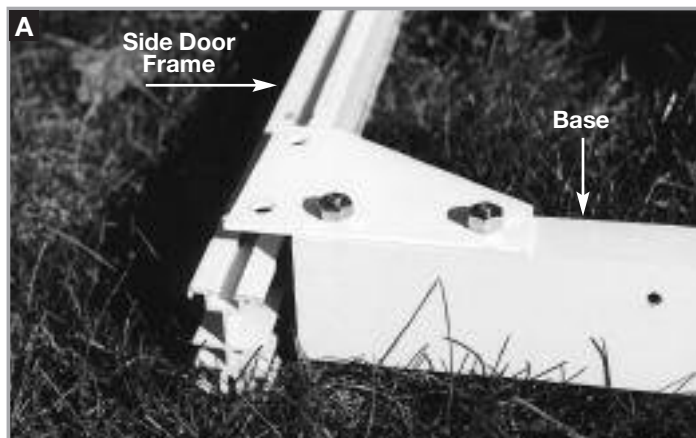

2. At the top of the doorframe, put on the doorframe header (which looks the same as the side pieces). Put the header *between* the two side pieces and bolt on the plates (6 holes). (See Pic **B**) The plates should stick up 1" above the doorframe. Note how the plates are put on. Before tightening the bolts, be sure to square up the doorframe (Page 10, #2).

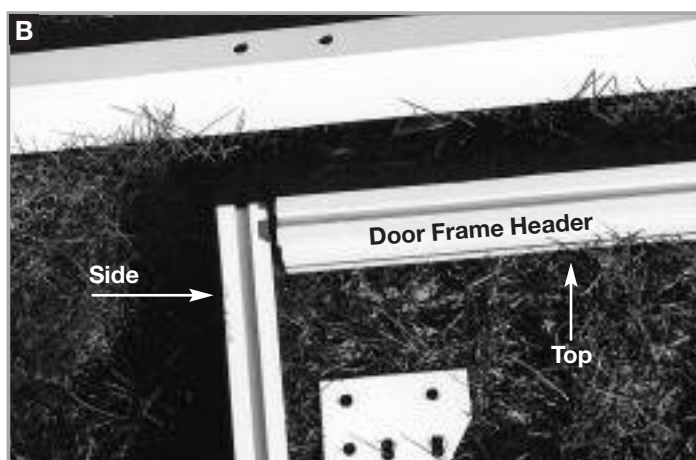

3. Take the corner post (angle cut on top) and bolt it to the base (Page 10, #3). Pic **D**

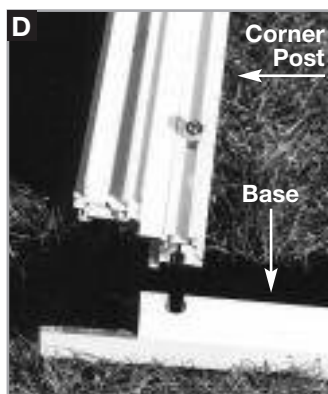

Front Gable End Assembly (contd.)

4. Take all the glass bars (next to the door frame - see #4 on Page 10) and bolt them to the base/sill. The angle cut should match the roof slope.

The 1" x 2" angle above the door (49³/₄" long) can now be bolted on. The 1/4" round holes should be facing up and lined up with the holes in the plates (The 2" side of the angle sits against the door header - See Pic **E** & **F**). Each end of the 1" x 2" angle has a slot punched out to accommodate the bolt that is lined up with the glass bars beside the door frame. Slide a bolt in the top of the glass bar and fasten the angle to it. (See Pic **G**). After the angle above the door is fastened to the glass bars and plates, slide the bolts in the top of the bars and fasten to the end rafter (See Pic **D** & **G**).

Next put in top brace (See page 11).

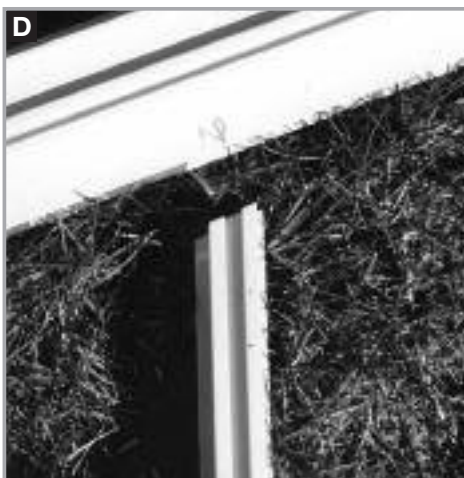

Sidewall Assembly

Lay out the sidewall with the gutter (See page 4 - #11) at the top - base at the bottom (See Pic **A**). You will notice that each sidewall glass bar has a straight and an angle cut. The straight end fits against the base (See Pic **B**) and the angle goes towards the gutter (See Pic **C**). Always face the bolt slot in the glass bar towards you.

1. Take all the glass bars and bolt them to the gutter (See Pic **D**). Start your bars approx. 2' in from the end of the gutter and base (See Pic **E**).
2. Bolt the glass bars to the base. Ensure bar fits tight to base and gutter.

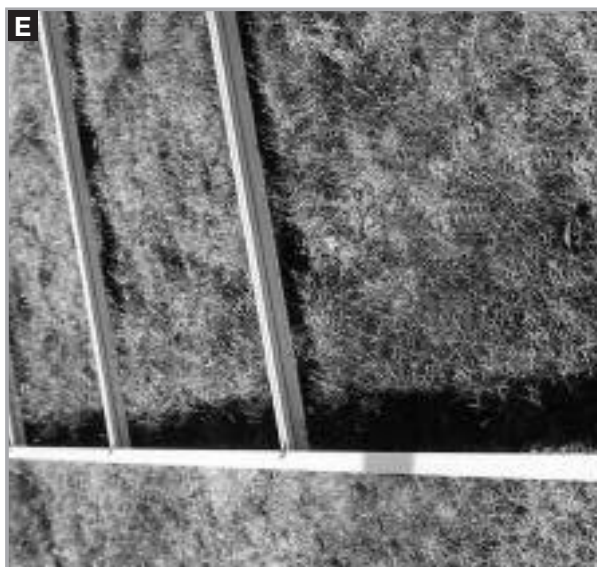
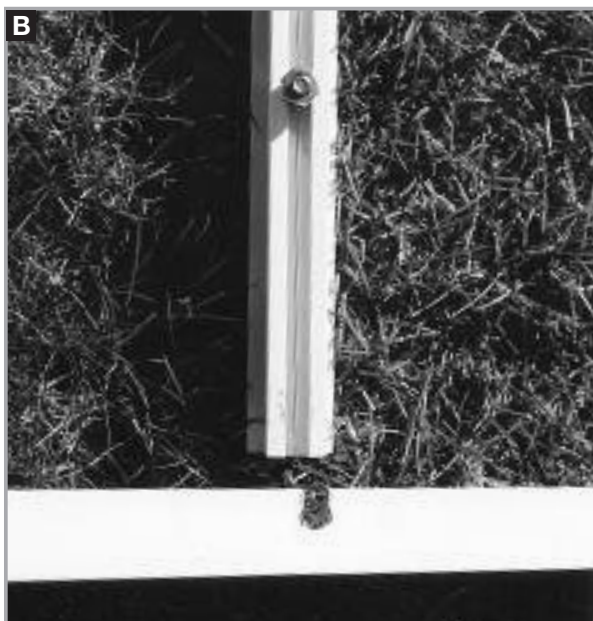
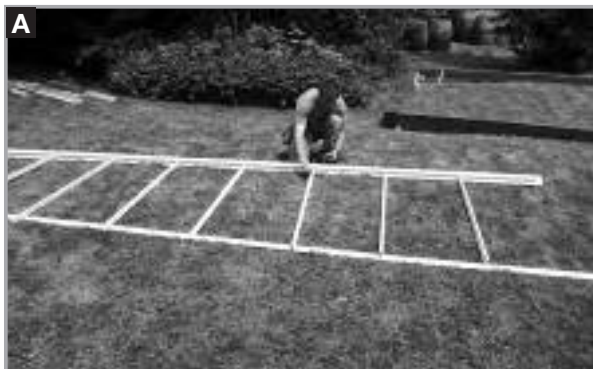

Aluminum Frame Assembly & Installation

1. BACK GABLE END (See page 17)

Take the end wall and slide a bolt into the corner post and end rafter (top and bottom) move it down and up approx. 3" and temporarily tighten the bolts.

2. Take the assembled sidewall and stand it up on your foundation. Slide the gutter (sidewall) in between the end rafter and the corner post. (There should be a 1/8" space - See Pic **A**). By sliding the gutter in as far as it goes, the punched out slots line up with the bolt track (See Pic **B**). Undo the bolts and slide it into the slots and tighten up. Do the same with the bottom base (See Pic **C**).

3. SIDEWALL (Page 18, Step 3)

Place the other sidewall on the foundation and slide the gutter into the back end rafter, fasten with bolts, bolt the base/sill to the corner post.

4. FRONT GABLE END

Follow the same procedure as the back gable end (Page 18, Step 4).



Aluminum Frame Assembly & Installation (contd.)

5. RIDGE (See Page 19 - Step 5).

For a small greenhouse, you can handle the ridge by yourself. Over 12' long it be easier with 2 people. Set the ridge on top of the end rafters in the middle of the greenhouse. Push the end rafter out and drop the ridge down 2" and slide it in-between as far as it goes. The bolt track in the glass bar lines up with the punch mark in the ridge. Undo the bolt and slide it up and fasten it (See Pic **E**).

5A. TRUSS ASSEMBLY INSTALLATION (See Appendix A).

5C. PERLIN INSTALLATION (See Page 23)

6. GLASS BAR WITH VENT SLIDERS (See Page 4 - #7)

Each glass bar has a small vent frame slider on it. They are marked 1/2/3/4 etc. On the ridge there will be the same markings. Slide a bolt in the top and 2 in the bottom of the glass bar. Put into place with the angle cut on top. Note that the numbers are the same so it can be lined up with the slots in the Ridge and gutter. Then fasten (See Pic **F**).

7. VENT FRAME BOTTOM SECTION (See Page 29)

(See Pic **G**) The vent frame bottom can now be placed between the glass bars that you have just installed. The 2" side of the angle faces towards the Ridge (See Pic **H**). Move the bolt up the glass bar and fasten it. Be sure the metal slider butts tight against the ridge lip.

8. REMAINING GLASS BARS (See Page 30)

All remaining glass bars can now be installed. Make sure that the top is tight against the ridge. Before you tighten the glass bar on the gutter, eyeball the gutter to see if it is straight. There is usually about a 1/8" space between the glass bar and the gutter.

9. Ensure greenhouse is square before fastening. Fasten the greenhouse base/sill to the foundation using #8 x 1" screws (if it is on concrete, drill holes using a concrete bit and push the plastic plugs into the holes). If possible, seal below the base before fastening the greenhouse to the foundation. (See Page 30)

Note: Make sure the greenhouse is fastened to the foundation with 1" screws.

10. Your greenhouse is now ready for putting on the 1/8" foam strips (Easier to foam before installing bars). Do not put the foam strips on the base or beside the door. Only use the foam on the glass bars & gutter. (See Page 28).

OPTIONALS

Side vents, intake shutters and exhaust fan installation. See Appendix A – F.

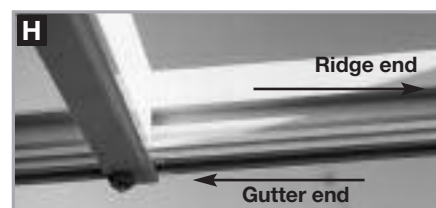

Assembly Outline

Step 1: Back Gable End

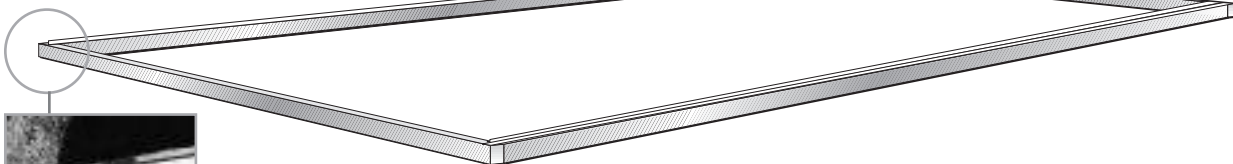
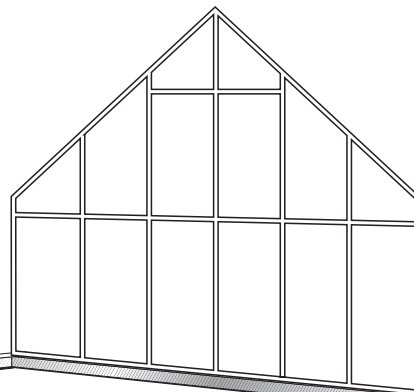

Step 2: Bolt Side Wall to Back Gable End

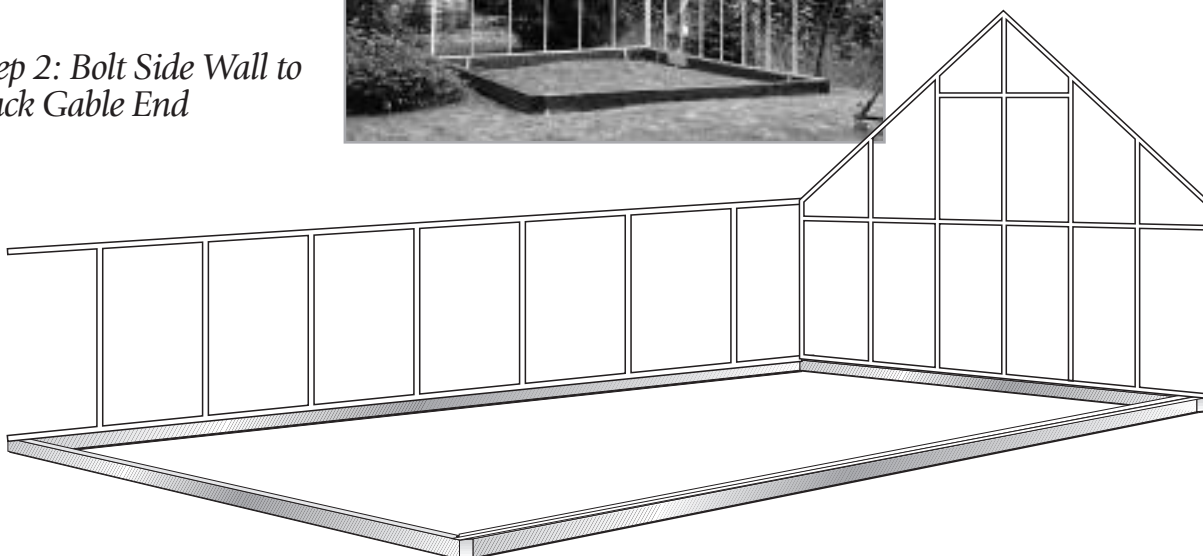

Step 3: Second Side Wall

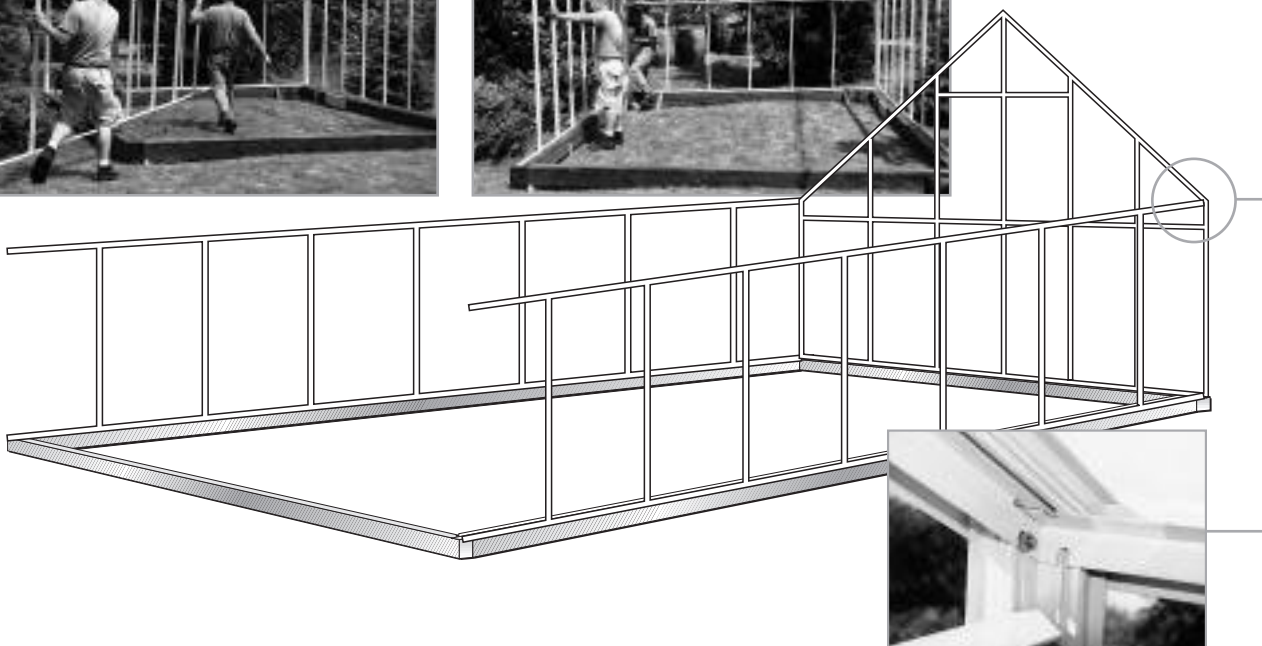
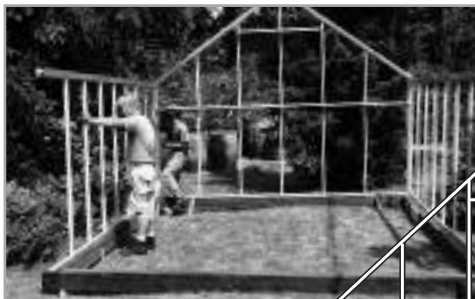

Step 4: Front

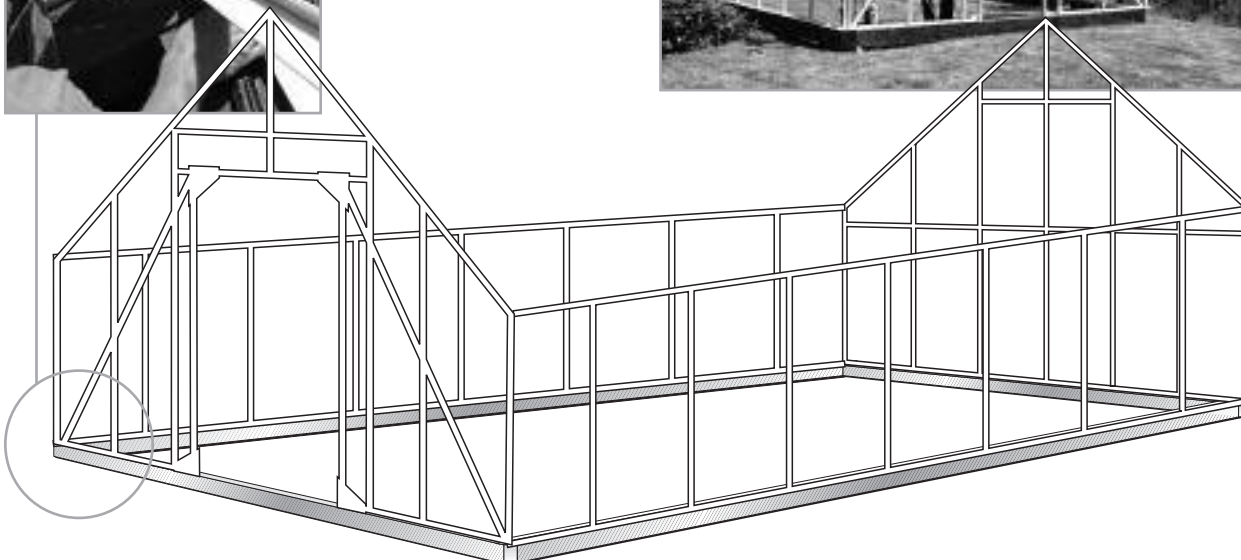

Step 5: Ridge

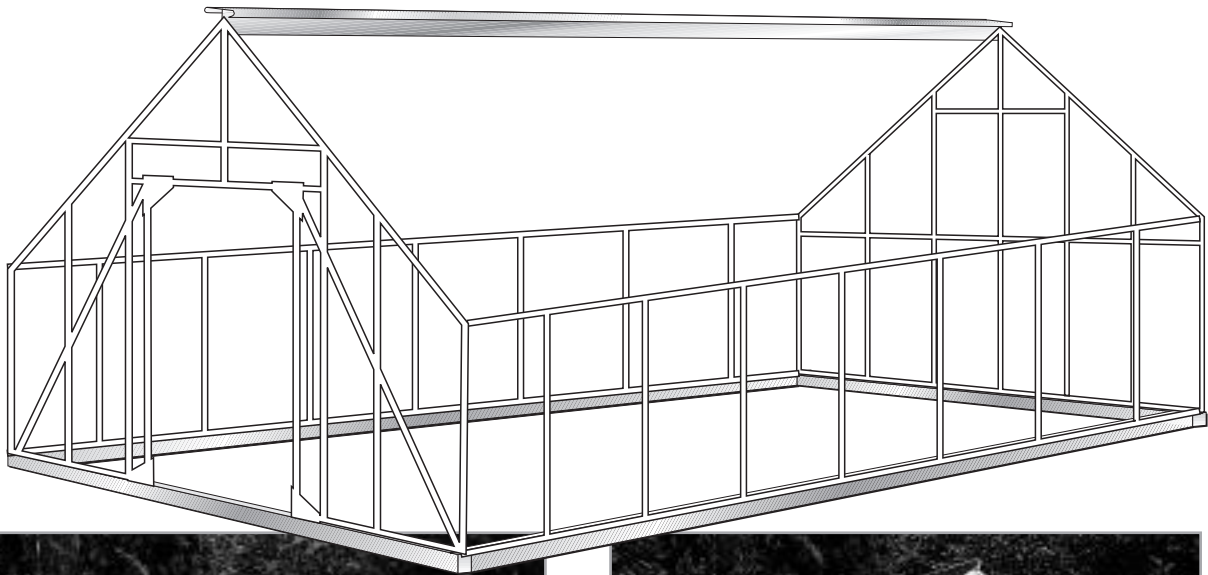

2' Aluminum Truss

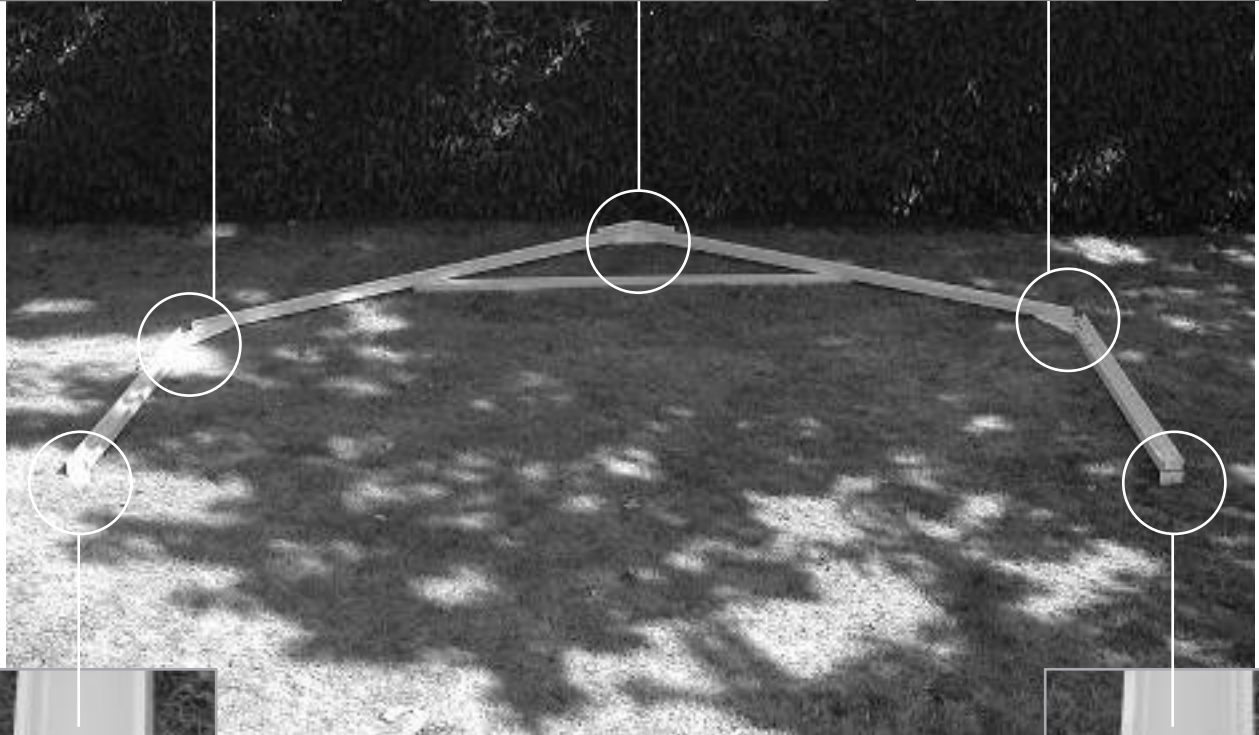
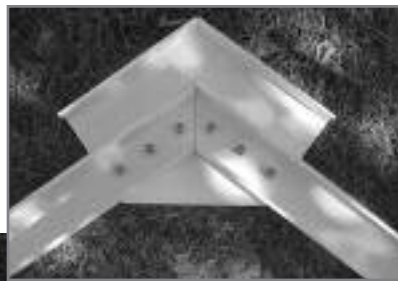

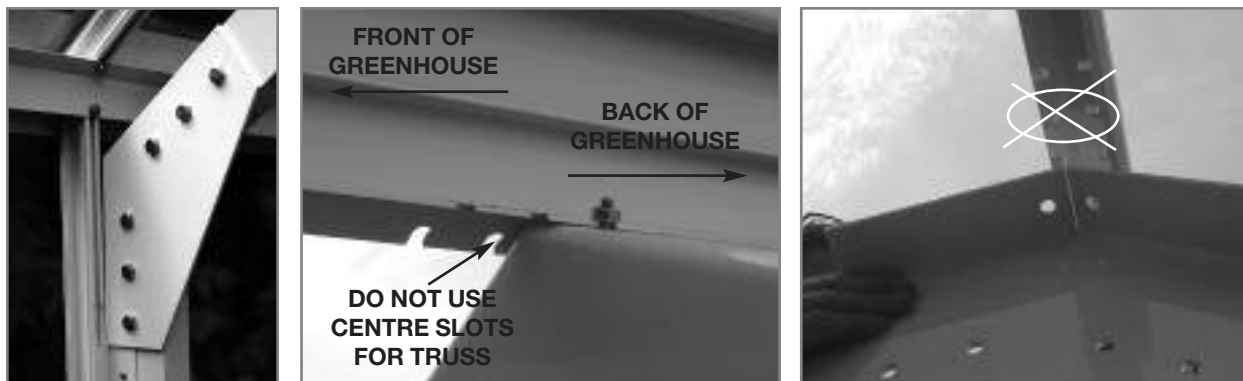

Do not use the centre slot on the ridge. This is for the glass bar. Use the front slots if the open side of the truss is facing the front of the greenhouse. Use the last slots of the closed side if facing the front of the greenhouse as it appears in the photos.





Step 5C: Perlin Installation

Larger greenhouses have perlin to increase strenght in roof structures.

A perlin can be a heavy or light channel. It usually sits on top of a truss and is bolted to the roofbars in the centre of the roof (*If you are using 2 perlins, balance the spacing between the Gutter and the ridge*).

Heavy perlin (*at least 1/4" thick*) requires 1/4" x 3/4" bolts. Smaller greenhouses use a light channel – bolts used are the same as the greenhouse bolts, 1/4" x 1/2."

Installation of a perlin is a simple matter of sliding the bolts into the roof bars and fastening the perlin (*see photos*).

Bolt Perlin with the open side facing up if you wish to use it for hanging baskets.

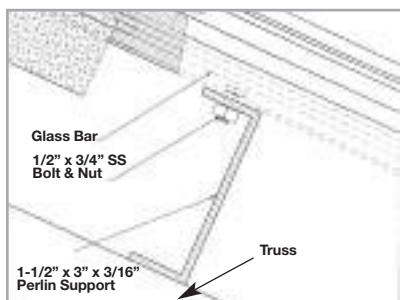

Step 5B: Truss Installation

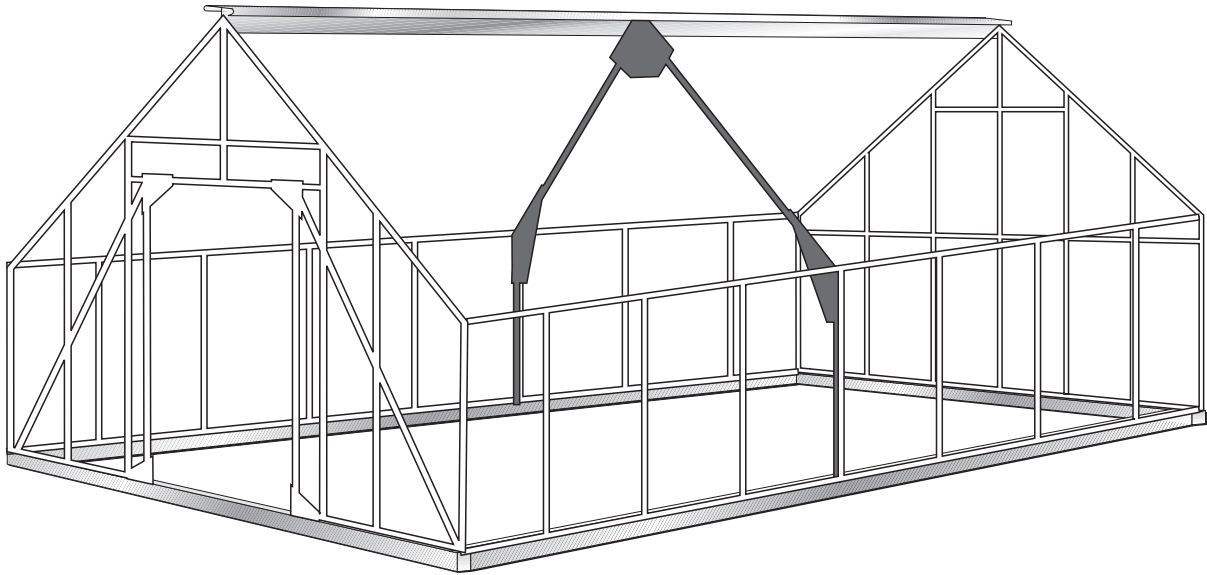

Step 5C: Perlin Installation

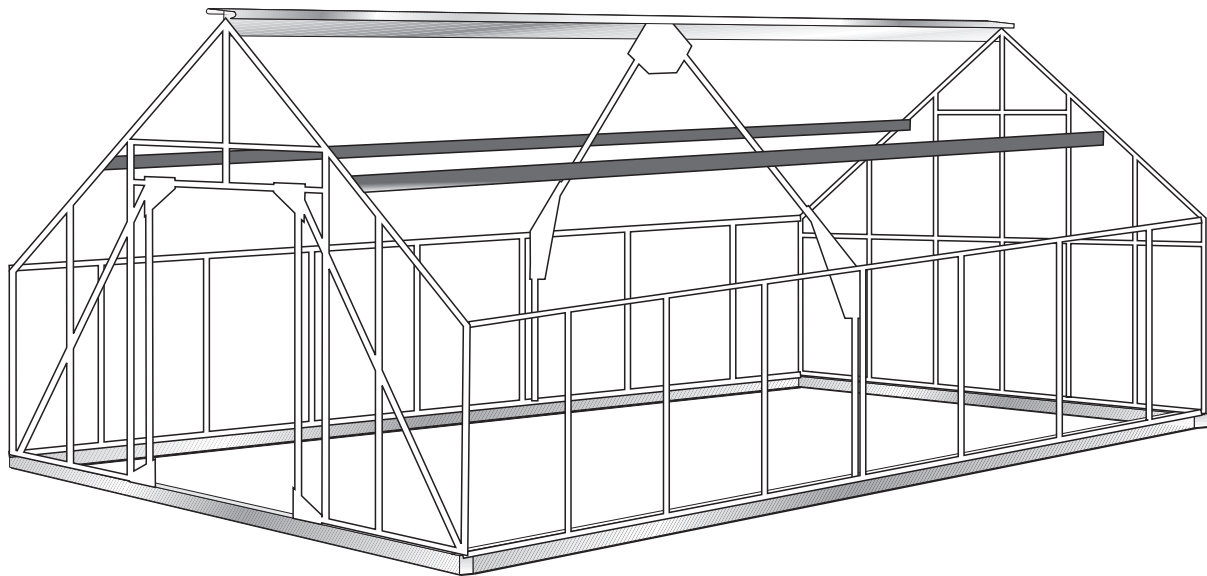

Step 6: Roof Glass Bar with Vent Frame Sliders

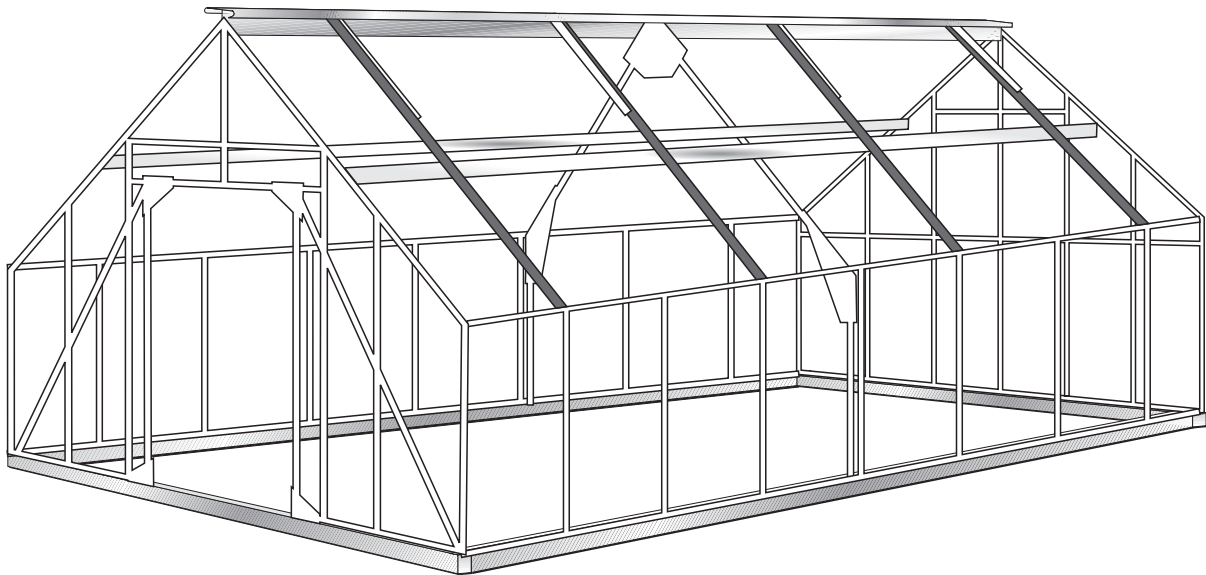

Step 7: Vent Frame Bottoms

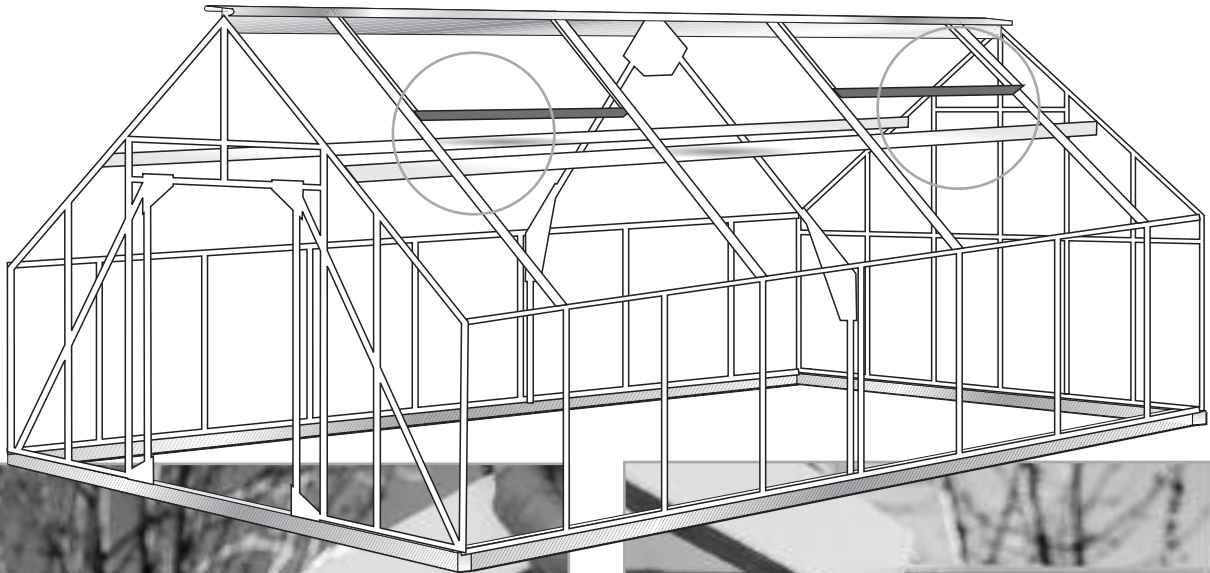

Step 8: Install all remaining roof bars

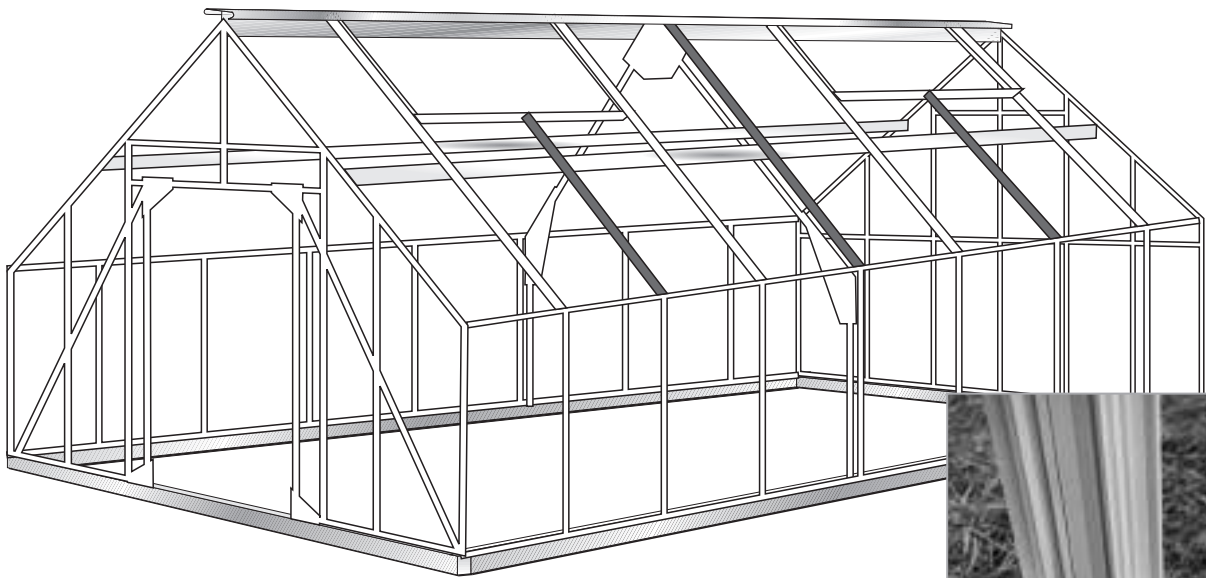

*Step 9:
Fasten the
greenhouse base/sill
to the foundation*

TAPING GLASSBARS WITH FOAM

Tape all the aluminum glassbars with 1/8" foam tape both sides. Take a roll of tape and start at one end and press on the bar. *Make sure that the aluminum is dry.* Slowly roll down the tape toward the outer edge and press it down at the same time (See Pictures). Be careful because sometimes the edge of the paper is quite sharp. Do not remove the paper until later.

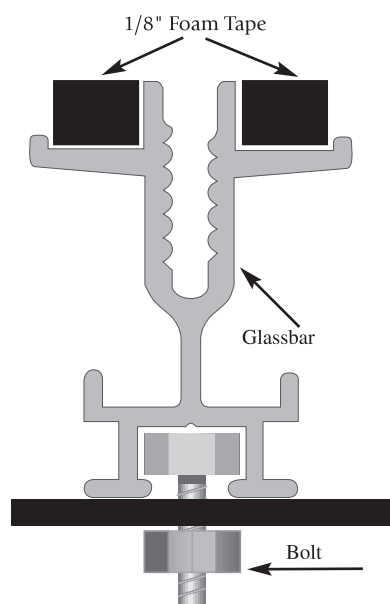
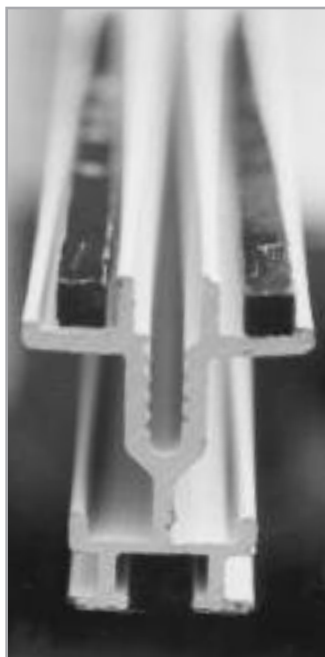

NOTE:

Taping the greenhouse can be done before you put the frame together.

If the weather is bad or dark outside, bring everything inside the garage and put the foam strips on the bars.

Make sure that the front / back / sides and roof bars don't get mixed up, it would make it much harder to put it together.

Glass & Cap Installation

GENERAL INFORMATION

Important points to consider:

- Square up (or adjust) the frame to fit the glass. If the foundation is square and level, the greenhouse will automatically be square when all the glass is in. Don't try to square up the whole greenhouse before you do the glass. Just do one side at a time.
- Always work one row across at a time.
- Don't over tighten screws ("finger tight" plus a quarter turn is sufficient).
- Position glass in between the inside edges of the bars.

Glass comes packaged in cardboard cases. When storing glass, put it upright against a wall or post. All glass is a 3mm / 24 oz. thickness (unless it is a special order). When handling glass, put one hand on the bottom and one hand on the side. Do not hold the glass flat on your hands. When laying out the glass for your greenhouse, do not lay the glass on your lawn while the sun is shining because the glass may/will burn the grass. (The following boxes ■ indicate the picture or illustration that will assist you with your assembly.)

GLAZING

Remove all paper from the foam strips. 1

SIDEWALLS (see the glass sketch for sizes)

- A. Take a piece of glass and hold it along the long side. Set the 24" width of the glass on your aluminum base against the glass bar and push it gently toward the greenhouse 2. If the greenhouse is not square, push the gutter over to square it. If it is a warm day, the foam will stick to the glass and you can walk away and get your aluminum cap. The cap (see sketch for

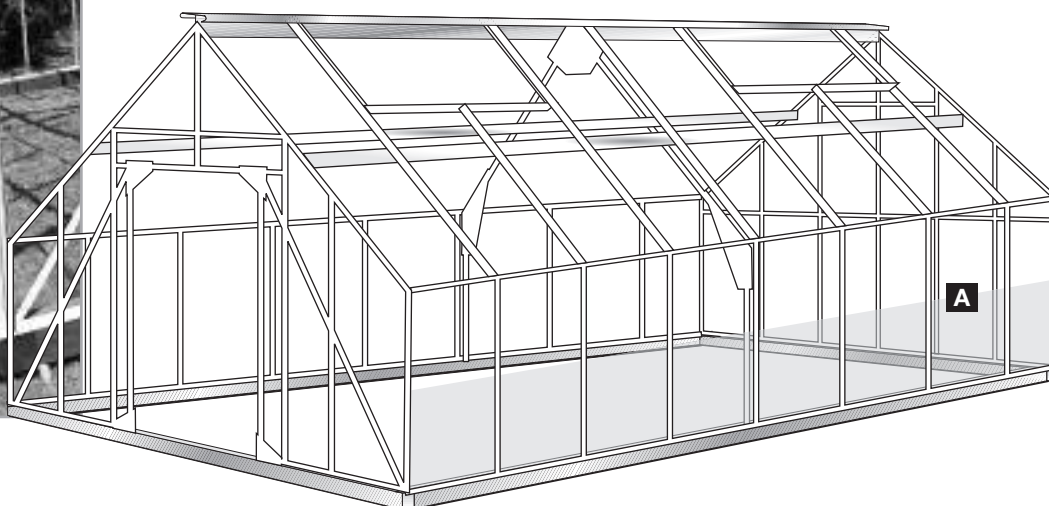

Glass & Cap Installation (contd.)

length) is pushed against the glass. **3** Use #8 x 3/4" screws to fasten the cap to the glassbar. Hold the cap against the glass and put in your screws. When the screw hits the cap, make a 1/4" turn. In other words, *do not tighten the screws too tightly*. Also, do not put a screw in the top hole of the cap. When the first piece of glass and cap is installed, go to the next bay. Finish off the bottom row on one side only.

- B. Install the next row of glass, push the glass underneath the gutter and set it on top of the bottom cap **4**. Take the aluminum cap (for length, see sketch). The bottom hole of the second row of caps line up with the top hole of the first row of caps. Again, do not tighten the screw too tight. On a standard greenhouse, this row will finish off the sidewall below the gutter. Always glaze both side walls before glazing the roof.



Please Note: If you must leave greenhouse partially glazed, please ensure frame is braced for possible damage by wind.

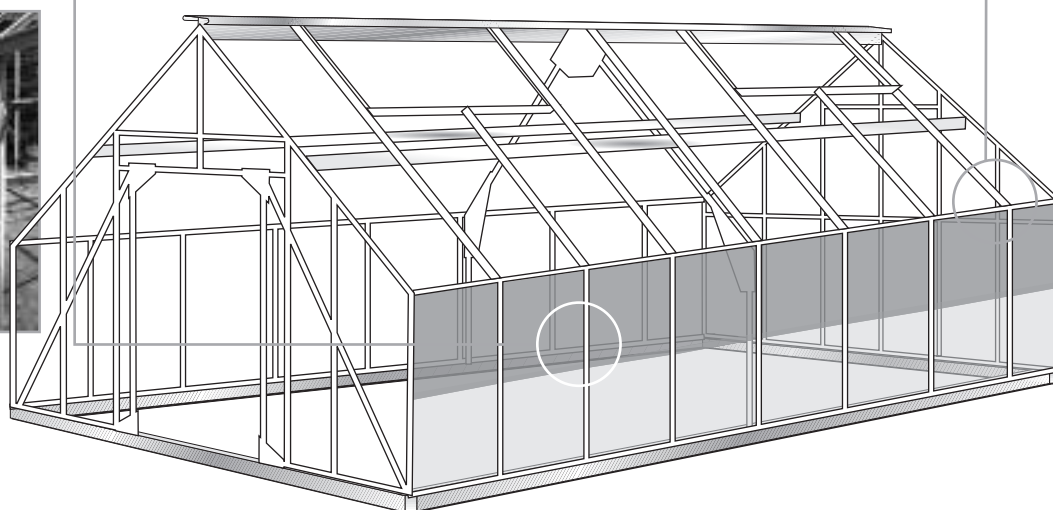
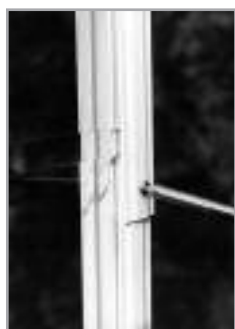

Installing the Roof Glass

INSTALLATION

- Install the glass by setting it in the horizontal gutter piece and letting it down slowly to the foam strip. If everything is square, level and plumb (straight), the glass should fit. If the glass does not fit - move the Ridge to either the right or left until a fit is obtained.
- Install the bottom row of glass on the roof first.
- Attach and fasten the Caps (caps are 1/2" shorter than the glass). (See Pic. A).
- Put in the second row of Roof Glass overlapping the first 1/2". Settle the glass against the cap. (See Pic. B).
- The second row of caps are 1" longer than the glass. When you put them on, the first hole in the cap lines up with the last hole in the previous cap.
- Before you lay down the second row of glass, cut a 8" (plus/minus) piece of foam and lay it against the first piece of glass and on top of the existing foam (it fills the space of the overlap).
- After you have finished the second row – the third row is installed the same way.
- Last row below the Ridge – the glass slips in underneath the Ridge flange.
- When the side of the roof is done, seal the glass below the Ridge and around the vent frame with silicone or caulking. Do the opposite side the same way.

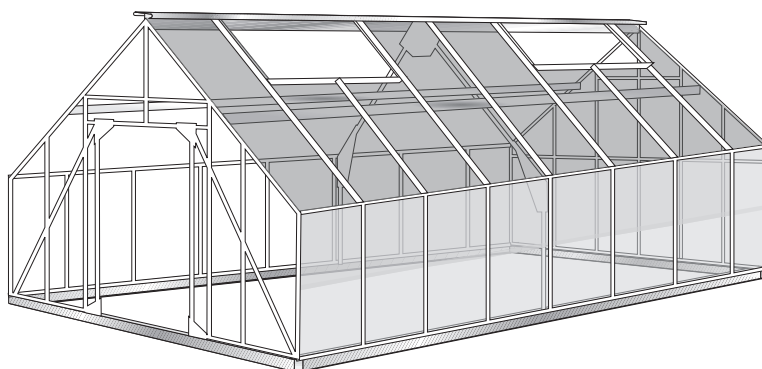

Installing Glass in the Door End

INSTALLATION

- Install the bottom row first. After setting the glass in place, attach the Glass Caps (see sketch for length).
- The second row and each succeeding row has the same size glass (as per sketch) but they overlap the previous row by 1/2" and are held in place by an Alum Cap (see Side Glazing).
- Do not caulk the bottom where the glass rests on the base. This allows for any condensation to seep out.
- The glass beside the door is pushed into the door frame. The second row of glass sits on a plastic "H" cane (See Pic **A** & **B**).
- Installing the Back Gable End Glass is the same as the front.

Note: Do not be afraid to adjust the frame to make it square with the glass. If the glass is off-square from one side of the door frame to the other, re-check your foundation for level.

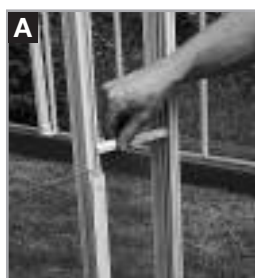

Sealing the Greenhouse

CAULKING: Mono 555 is used for sealing aluminum to the wood / concrete base.

SILICONE: is used when sealing aluminum to glass. The areas that need to be sealed with silicone are:

- Below the ridge **1**
- Around the door frame **2**
- Angle above the door **3** **4**
- Around the vent hinge and vent frame **5**
- Beside the door frame **6**
- *Caulk* the corners where the side and end base meets (on the outside of the greenhouse only).



Door Installation

(Refer to the drawing - Page 35) Take the door and set it inside the door frame. Lift it up as high as possible on the hinge side and put the screws through the existing holes in the door frame. Now the door will hang by itself.

Remove the clip from the "Z" bar and put one screw into the door frame to hold the "Z" bar. Open the door, take off the clips and put back the screws. Close the door and check that it is square. If the frame and the door are square, then fasten the "Z" bar to the frame. If not, move the "Z" bar up or down to square it. If this is not enough, loosen the bolts in the top plates and move the frame to make it square. When it is in place, tighten all the bolts.

Next install the door handle (see the instructions inside the box). To install the door catch angle, slide in two bolts into the back of the door frame. Bolt on a small angle (provided with the door handle). Face the angle towards the door, line it up with the center of the door handle, and then tighten the two bolts (see picture to the right). Take the door catch out of the door handle box and screw it on. Close the door and adjust the door sweep at the bottom of the door to eliminate potential gaps.

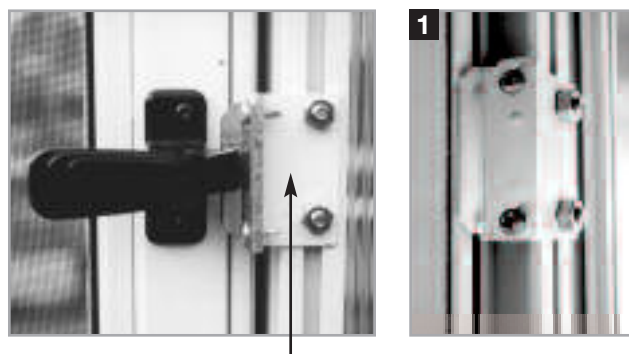

Door Catch Angle

NOTE: There are two types of manufactured doors. The door catch angle on the white door may have to be turned the opposite way as shown on picture 1.

Run a bead of silicone under the angle above the door and against the door frame. Also silicone the glass beside the door to ensure an airtight seal.



Door Installation

TRADITIONAL SERIES COTTAGE ROOF FREE STANDING MODEL • GREENHOUSE INSTRUCTIONS

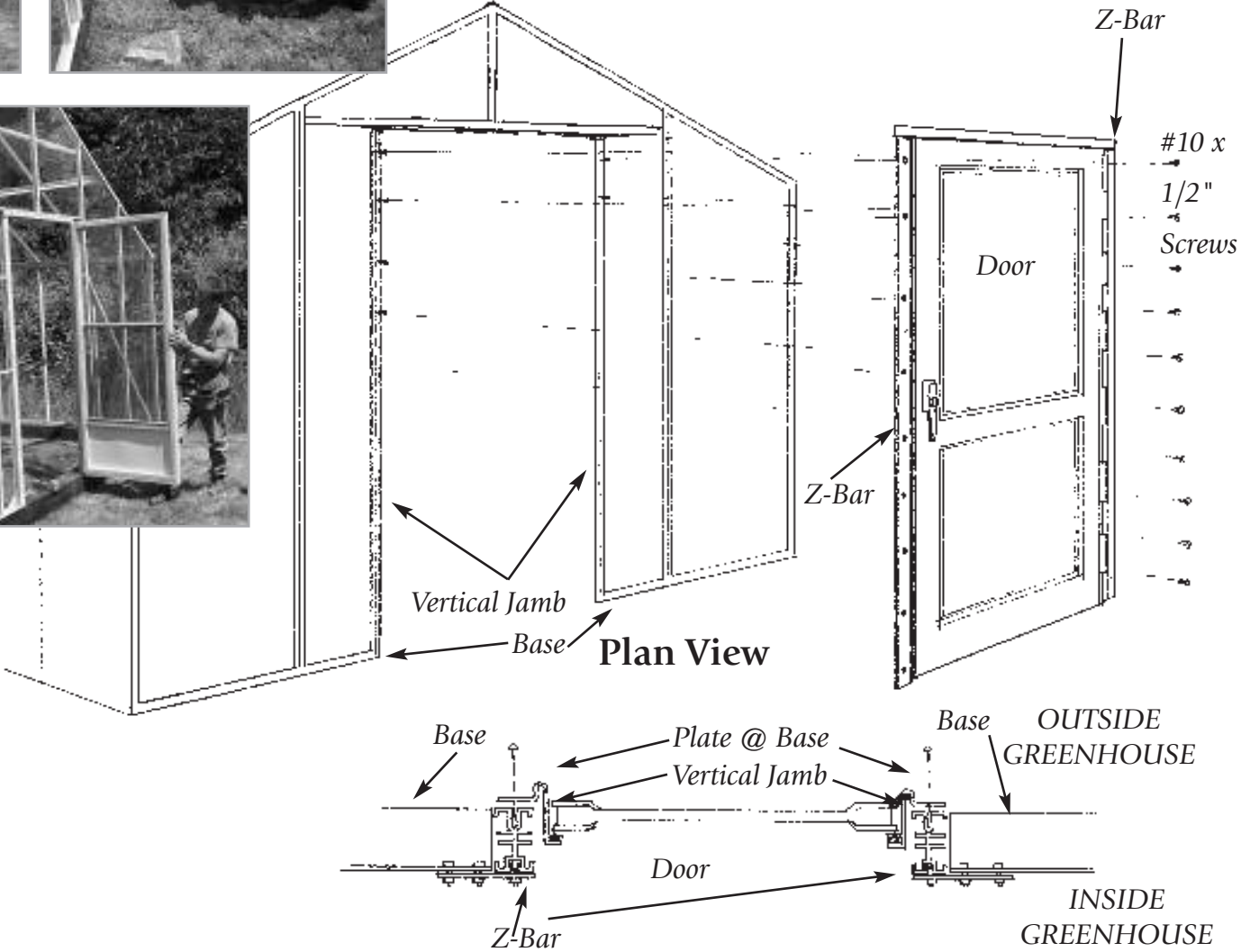

Vent Assembly

(See Photos on Page 37, Drawings on Page 38)

1. Lay down the vent gutter with the punches facing up towards you.
2. Glass bars with sliders are for the end. Lay them down with the bolt slot facing up.
3. Lay the vent hinge with the punches facing up towards you.
4. Slide the bolts into both ends of the end bar (1/4" x 3/8"). Take the gutter and line up the bolt with the first punch, slide the bolt down and tighten it. Do the same with the hinge, the other side and center bar. Make sure that the Glass bars fit tightly into the gutter and hinge after the vent is assembled.
5. Turn it over and square it up.
6. Put the 1/8" foam on the Glass bars and Gutter.
7. Take the glass and slide it up into the hinge track. Drop it down on the gutter. Do the same with the next piece of glass.
8. Take the caps and lay them on the bars, center them and screw them on with a 3/4" screw.
9. Take the silicone gun and seal where the glass slides into the hinge.

VENT INSTALLATION

Take the vent and slide it into the end of the ridge (See Pic. **A**).

After you remove the screw in the ridge, push it into place and put the screw back in (See Pic **B**). Now attach the manual opener if applicable. (See Pic **C**).



Glass Greenhouse Roof Vent Details

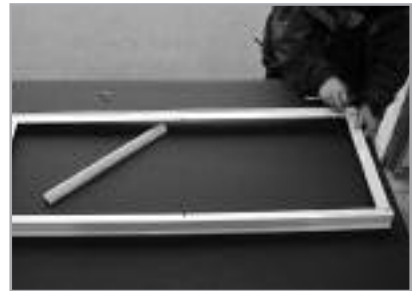
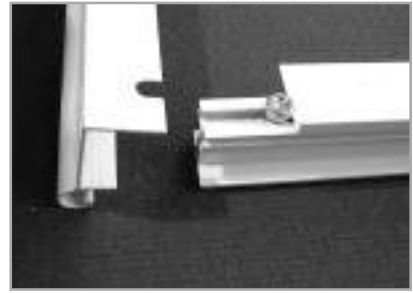

Vent Assembly Exploded View

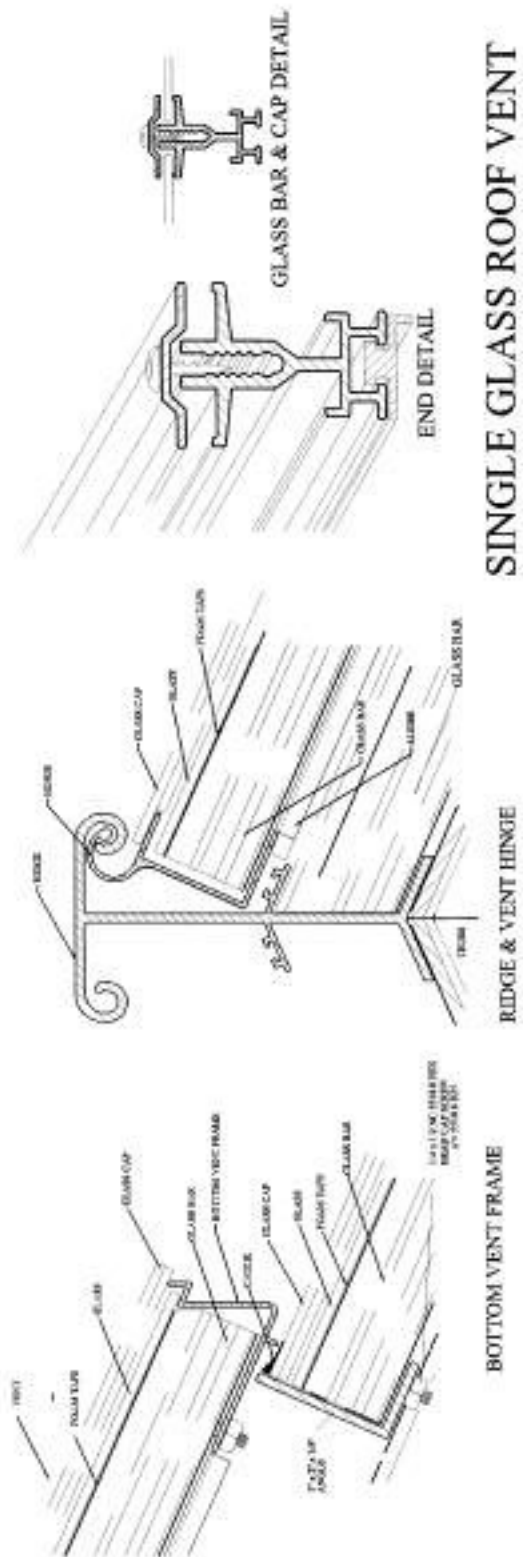
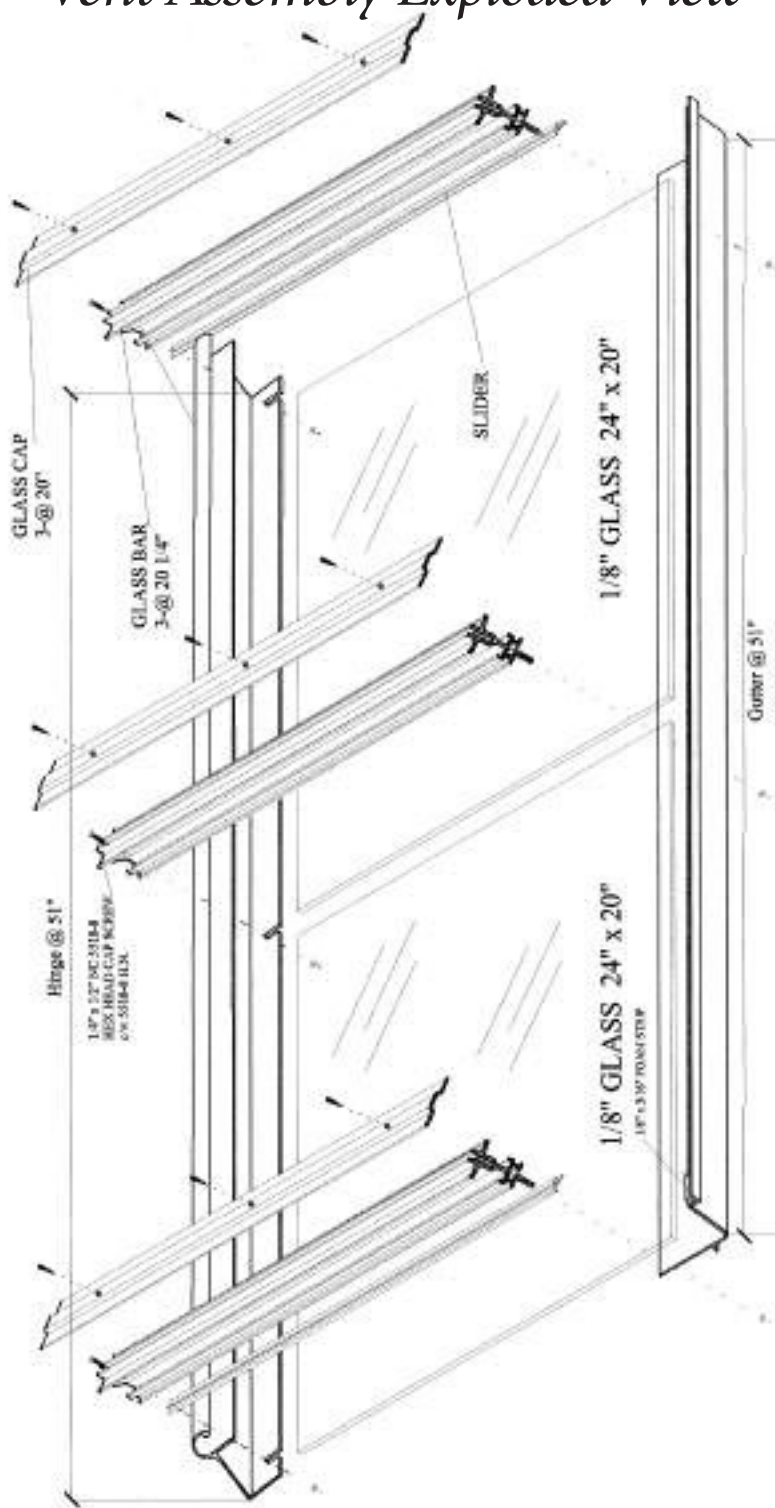

SINGLE GLASS ROOF VENT

Sketches

Free Standing Greenhouse Models No. 600 to 2000

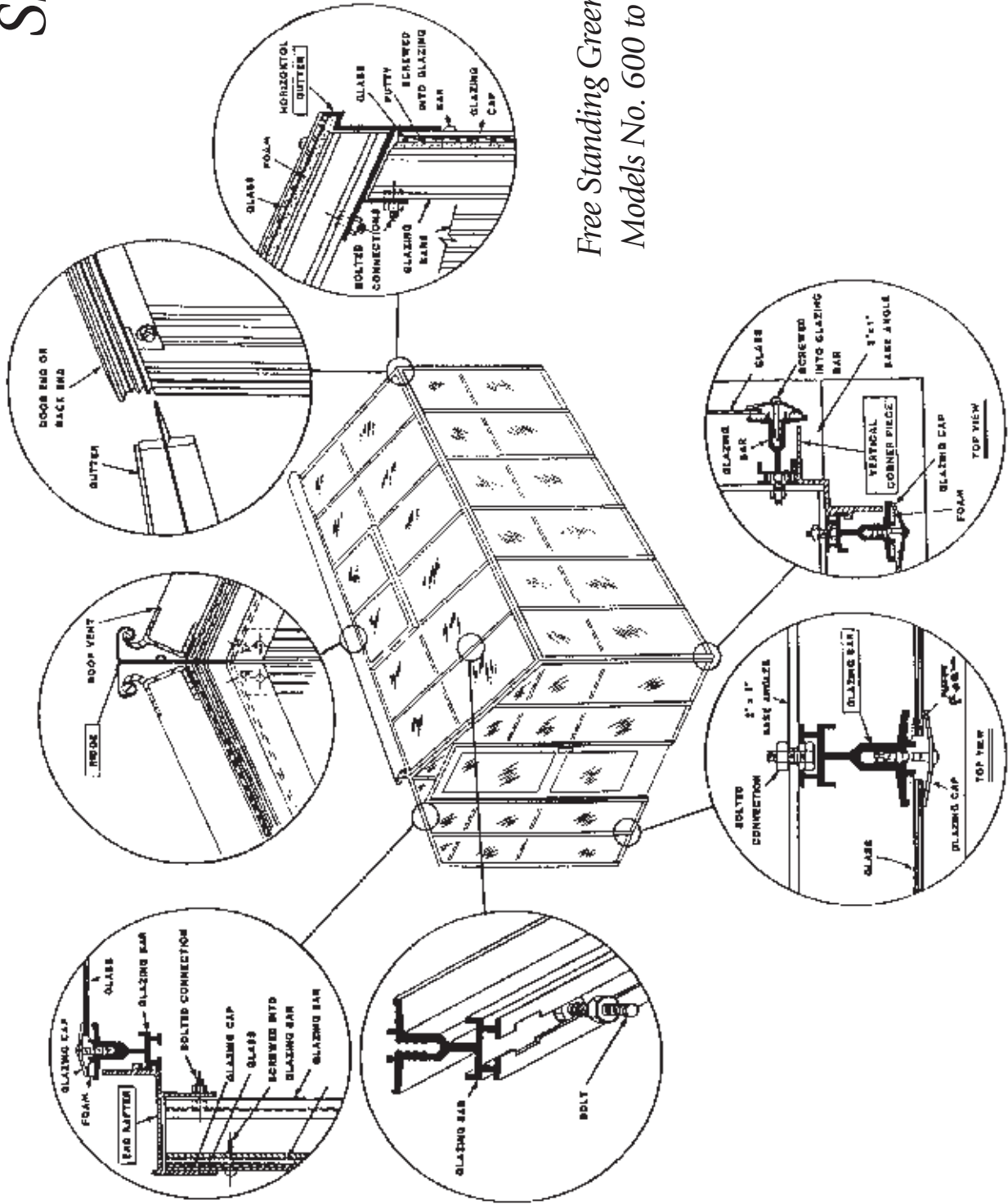

Appendix A – Vent Opener

INSTALLING THE BAYLISS AUTOMATIC VENT OPENERS

Detailed instructions are included in the box with the control (there are a few extra parts). Use #8 stainless steel screws to fasten the Bayliss and the vent sill (1) and the vent (2). All holes are already drilled.

After the Bayliss is fastened in place, install the threaded adjuster into the swivel block. This is made easier by lifting the vent with one hand until the piston rod only projects 1/2" through the swivel block.

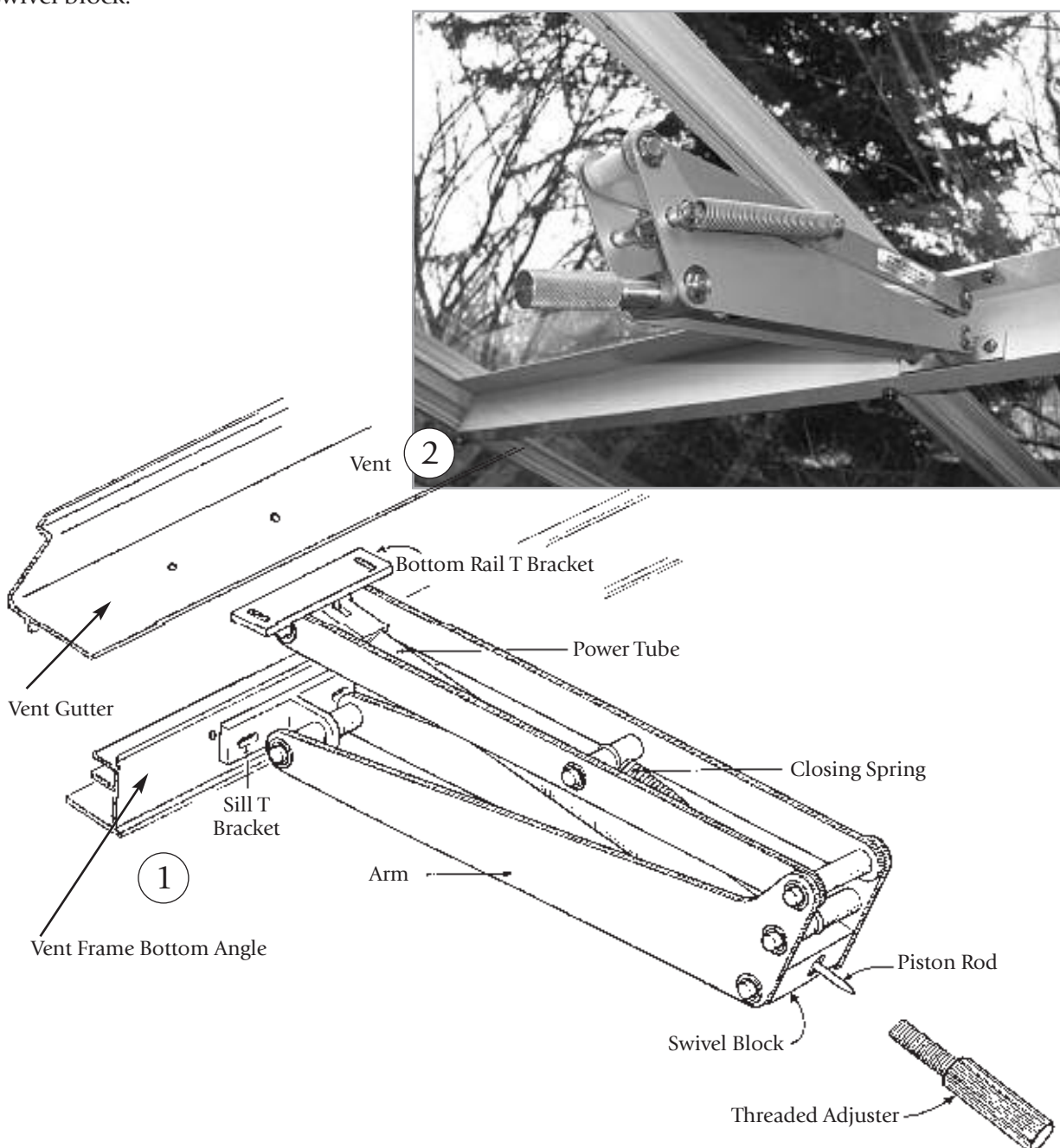

Appendix B – Exhaust Fans

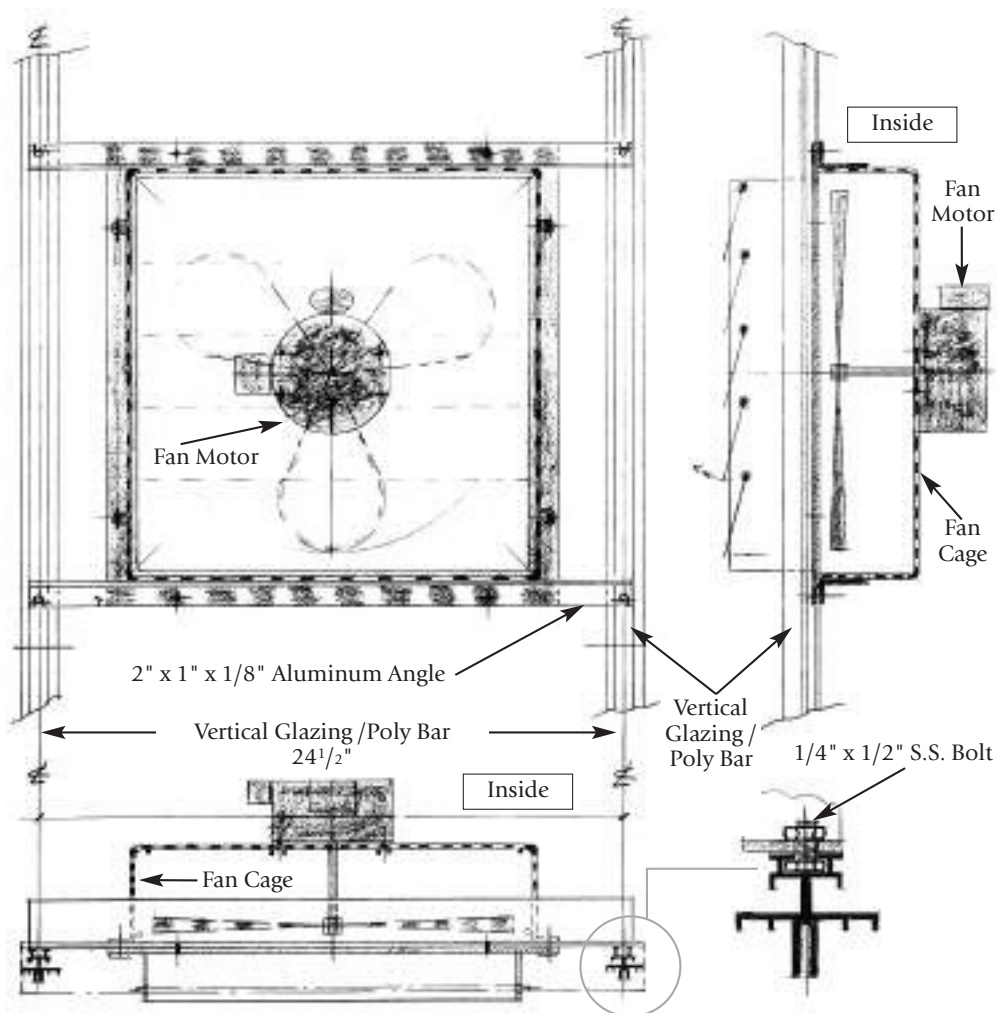

- Slide bolts into vertical bars beside fan bottom.
- Temporarily tighten.
- Insert fan in square cutout of acrylic piece.
- Slide bolts into slots on angle and tighten
- Seal around shutter on outside.



Appendix C – Side Vent

GLASS OR POLYCARBONATE SIDE VENT ASSEMBLY

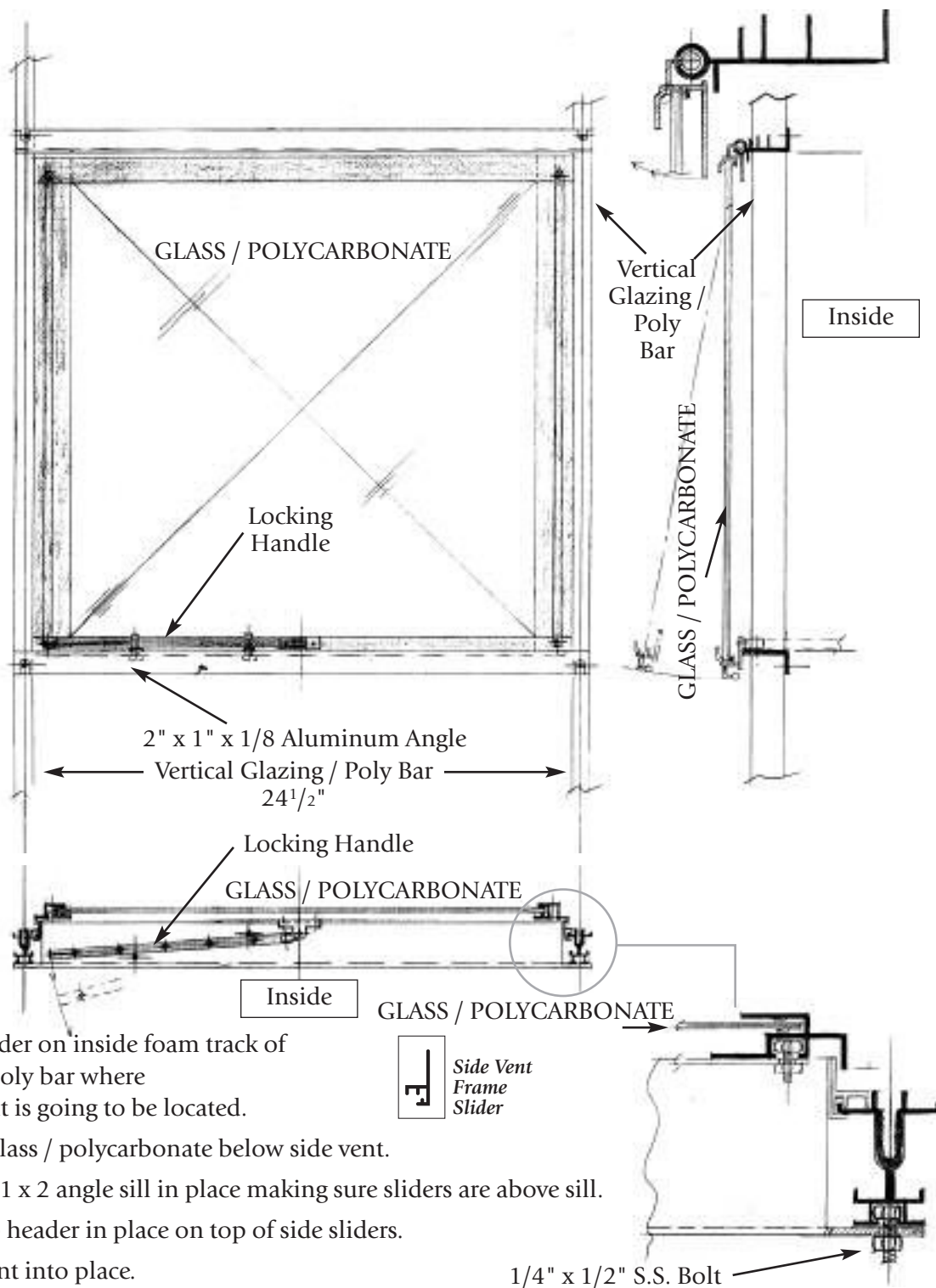

1. Slide slider on inside foam track of glass / poly bar where side vent is going to be located.
2. Install glass / polycarbonate below side vent.
3. Bolt on 1 x 2 angle sill in place making sure sliders are above sill.
4. Bolt top header in place on top of side sliders.
5. Slide vent into place.
6. Install automatic or manual opener.

Appendix D – Side Vent CONTINUED



Appendix D – Glass Louvre

GLASS OR POLYCARBONATE GLASS LOUVRE ASSEMBLY



Outside view

Inside view



Appendix E – Diagonal Brace

Diagonal Braces are used for larger greenhouses – 16" and up.

INSTALLATION

1. Unwrap the brace, loosen up the bolts on the ends and turn the angles. **#1**

2. Take the end of the brace with the straight angle and bolt it to the end wall. **#2**

3. The other end is fastened to the ridge. You can use a self-drilling screw (supplied) or pre-drill the hole using 9/16" drill bit. **#3**



Appendix F – Polycarbonate Panels & Cap Installation

GENERAL INFORMATION ABOUT HANDLING POLYCARBONATE

All polycarbonate sheets are covered with a thin sheet of plastic on both sides to prevent the sheets from becoming dirty and scratching during handling. One side is a clear plastic while the other side is blue or some other colour, depending on the manufacturer. This latter side should be installed so that it faces out. (**VERY IMPORTANT: The sheet is marked to indicate which side should face out.**)

Before you begin installing, lay out the sheets lengthwise so that it is easier to take the one you want to install. Do the same with the capping.

Remove all the paper on the foam strip on the greenhouse before you begin installing the panels. If the weather is warm and sunny, the foam strips will be sticky. Take a trigger spray bottle and fill it with soap and water. Just before you install the panels, spray the foam lightly so that the panels can be moved around.

Do not store polycarbonate bundles outside in the sun. Instead, store them in a cool dark place, such as a garage, until you are ready to use them.

To clean polycarbonate panels, use soap and water only – do NOT use any chemicals – they will damage the panels.

ROOF POLYCARBONATE PANEL INSTALLATION

NOTE: When you install the roof panels, start on the far side of the roof vent opening. Work towards the vent opening. When installing the last pieces in the roof you can reach it through the vent opening and do not have to move your ladder outside.

Start with the roof panels. Peel off the plastic. (See Picture 1, page 47) Remember to mark the corner so that you know which side is out (The blue plastic indicates the outside; the clear plastic indicates the inside). Put an aluminum "H" on the bottom of the sheet (Picture 2, page 47).

Then slide the panel into the top track (Picture 3, page 47) and the bottom of the panels with the "H" into the gutter. The long leg of the "H" faces outside (Picture 4). (The gutter should have NO foam on the ledge where the lip of the "H" rests) If the Poly Bars do not line

up with the panel, move the greenhouse ridge toward the front or back until the bars line up. This "squares up" the roof section. Spray the foam with water if it is sticky. The shorter pieces should be placed under the vents. Finish the one side of the roof.

Take the cap, hold it against the panel and position it in the center of the Poly Bar (Pictures 5, 6 & 7, page 47). Use #8 x 1/2" screws and screw it on the Poly Bars (You could use a portable drill with screwbit to do this job, just don't make it too tight). Continue to the next panel and follow the same procedure.

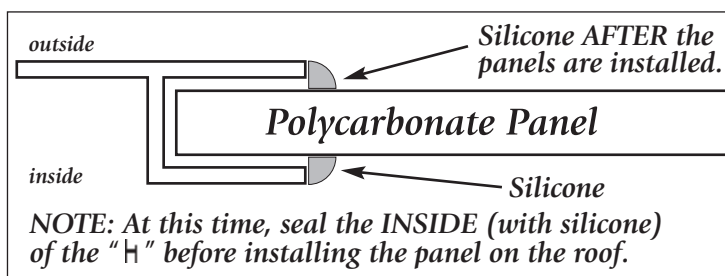

Appendix F – Polycarbonate Panels & Cap Installation CONTINUED



Appendix G – Motorized Intake Shutter

INTAKE SHUTTER ASSEMBLY

Inside View

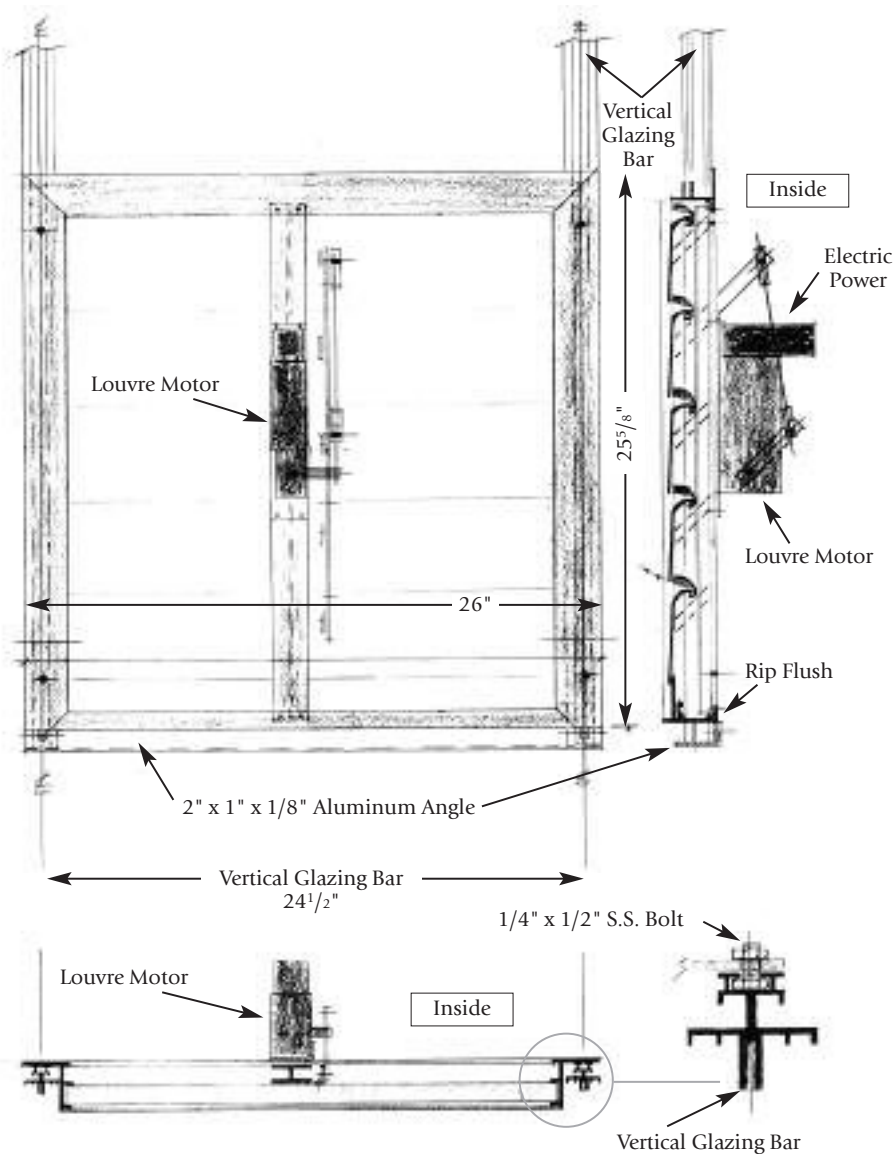

Outside View



Appendix H – Cedar Bench

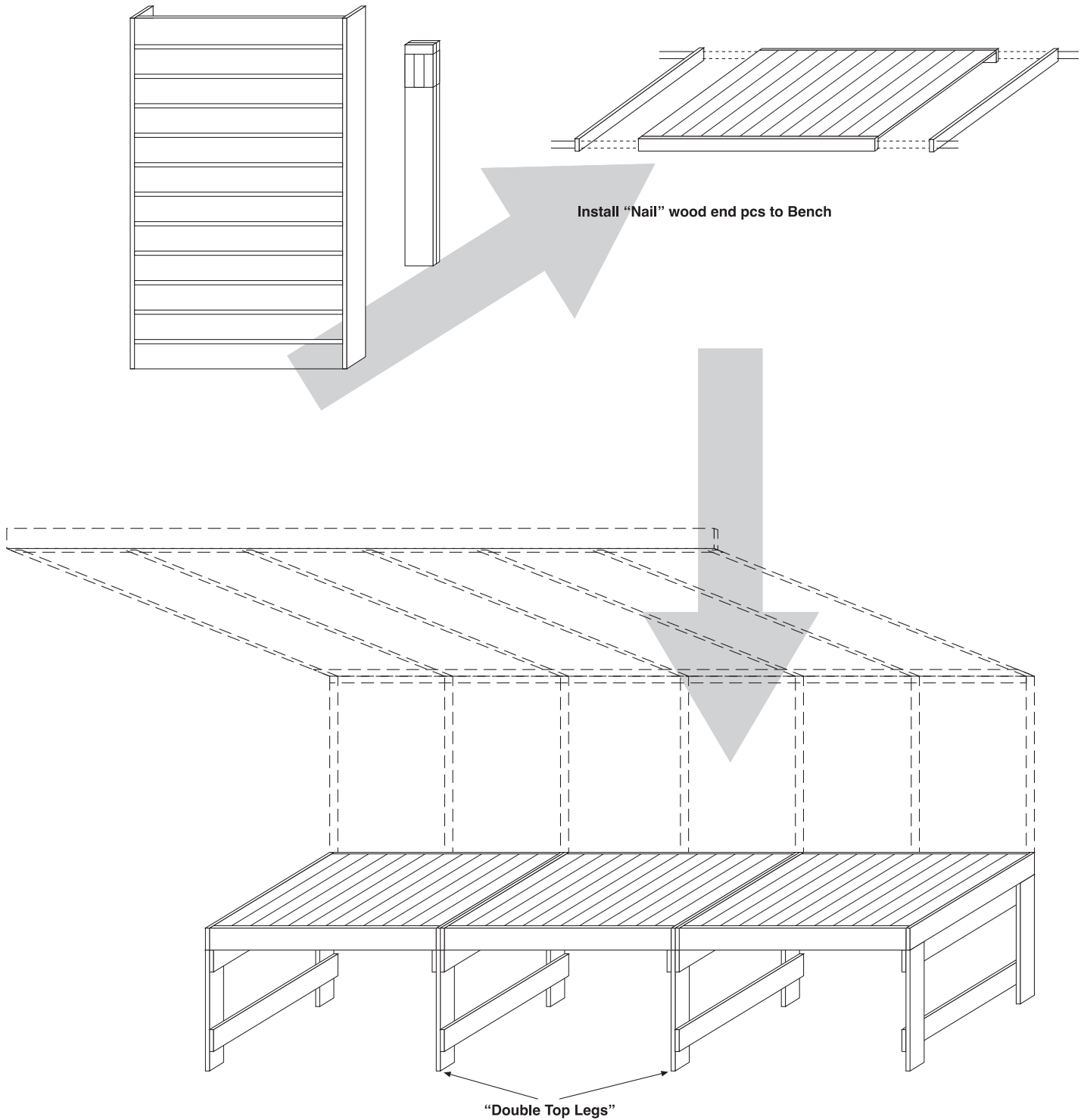

Appendix I – Greenhouse Bench

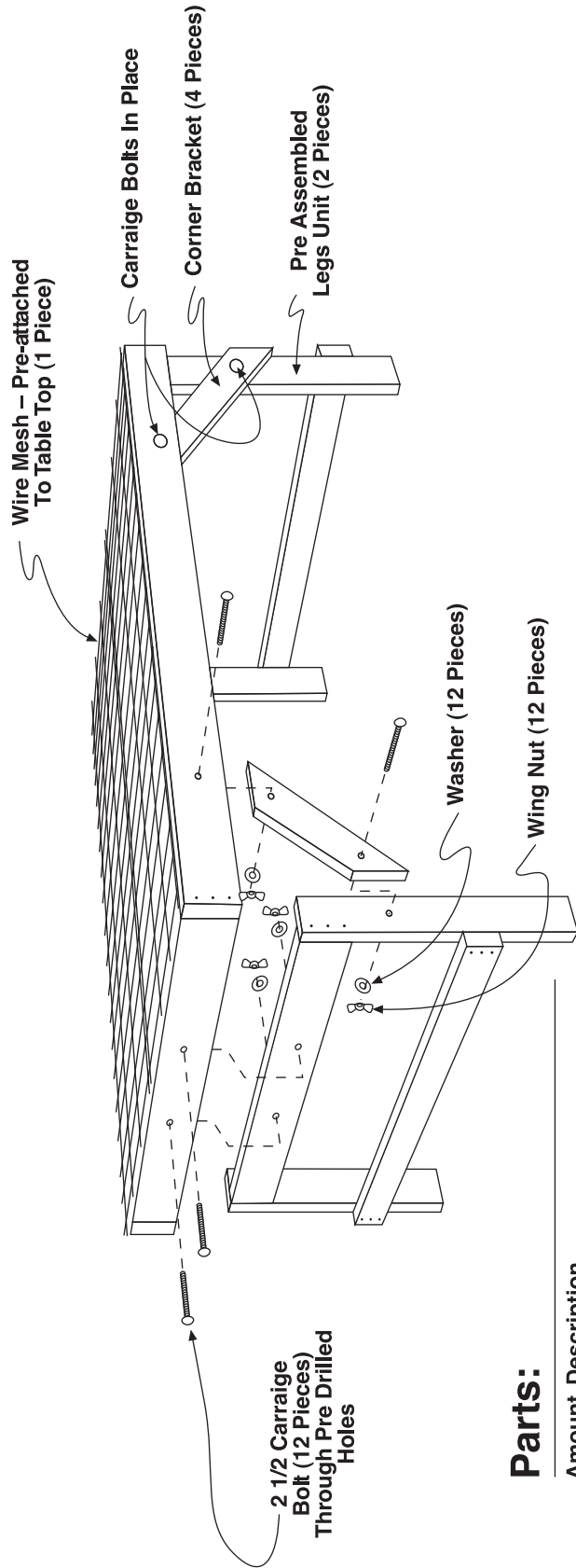

Parts:

Amount	Description
1	Table Top = W/ Pre-attached Wire Mesh Plastic Coated W/Guide Holes
2	Leg Units = Pre-assembled W/ Guide Holes
4	Corner Brackets = W/ Guide Holes
1 Bag	Contains: 12 – 2 1/2 Carrage Bolts 12 – Washers 12 – Wing Nuts

Appendix J – Roof Vent Screen

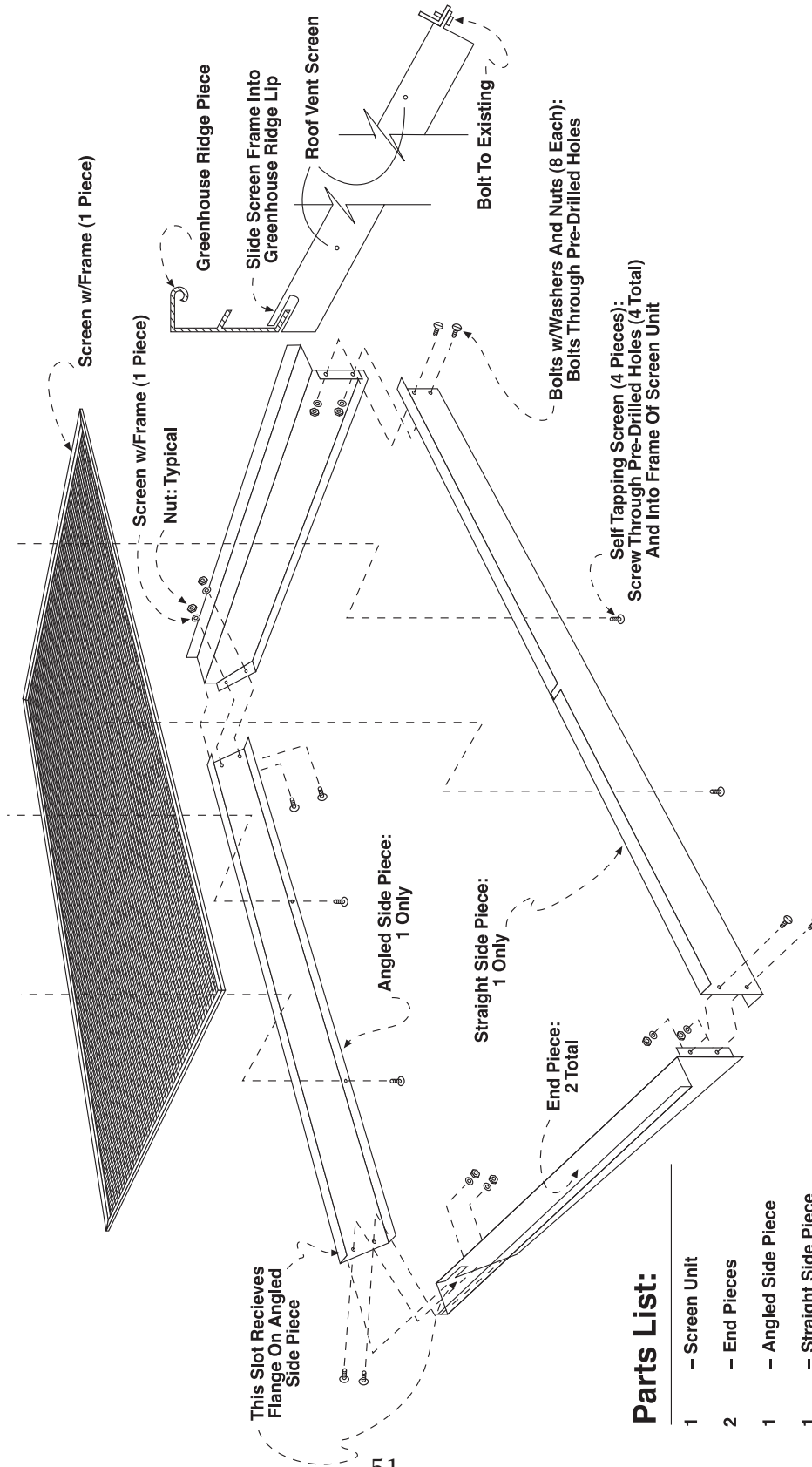

Parts List:

- 1 – Screen Unit
- 2 – End Pieces
- 1 – Angled Side Piece
- 1 – Straight Side Piece
- 1 Bag With:
 - 8 – Bolts
 - 8 – Washers
 - 8 – Nuts
 - 4 – Self Tapping Screws

Appendix K – Side Vent Screen

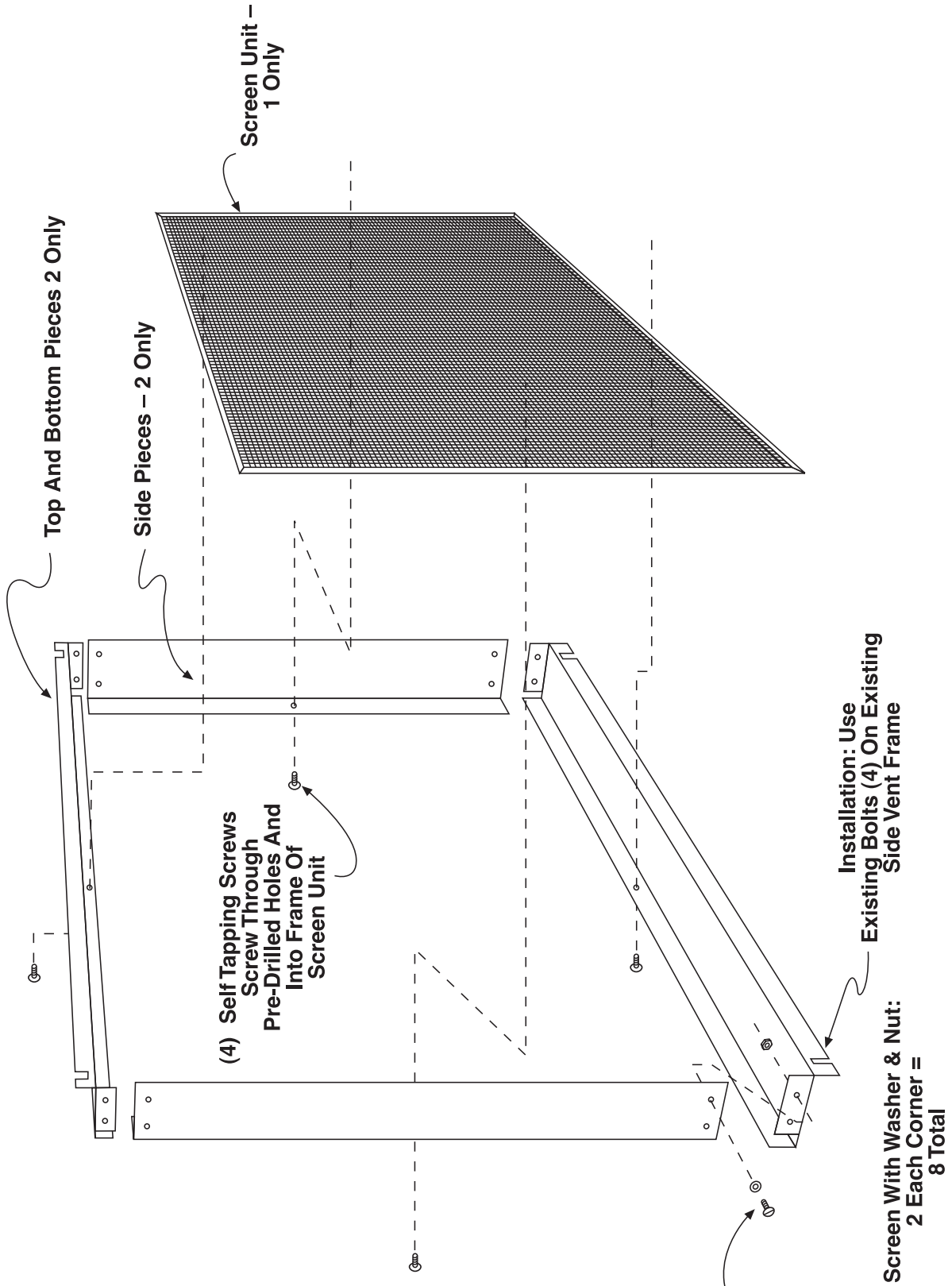

Appendix L – Wire Shelving

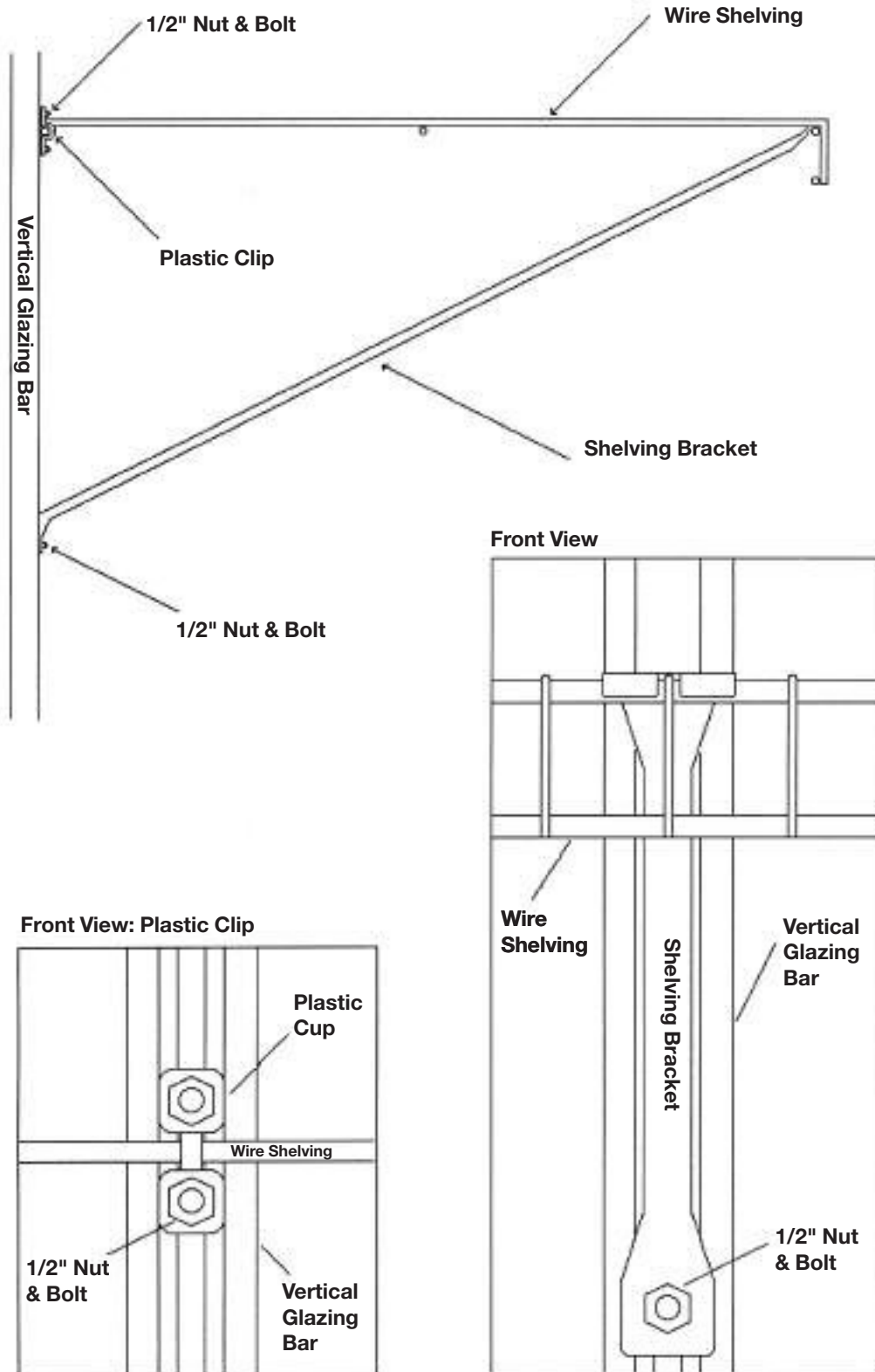



*At this point, stand back and enjoy your workmanship.
Your Traditional Cottage Roof Free Standing Greenhouse
should now be closed in and ready for use.*

Congratulations!