



Dual Fan and Shutter System Installation Guide

NOTE: 2 & 3 speed fans are not setup to be hard wired. You will need to cut the power supply cord and connect directly to the black (hot), white (neutral), and green (ground) wires inside the cord if you want to hard wire them.

- VARIABLE SPEED FANS ONLY -

Wiring information for each variable speed fan is located on a sticker on the motor.

If you will be hard wiring one of our variable speed fans, make note of the black, white, and green wire connections before disconnecting the power supply cord, and make sure the wire used to hard wire the fan is connected to the same terminals.

Our 1/2" watertight wiring connectors or 1/2" flexible conduit connectors can be screwed directly to any of the variable speed fan motors. Flexible conduit and connectors are included in our vent system wiring kit or can be purchased separately. 14 gauge or thicker wire is recommend when wiring the fan and any other venting supplies purchased from us.

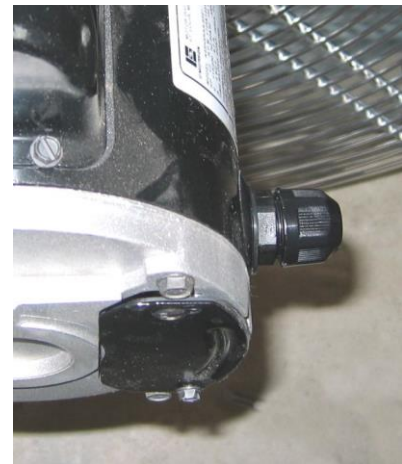

Exhaust Fan & Intake Shutter Dimensions

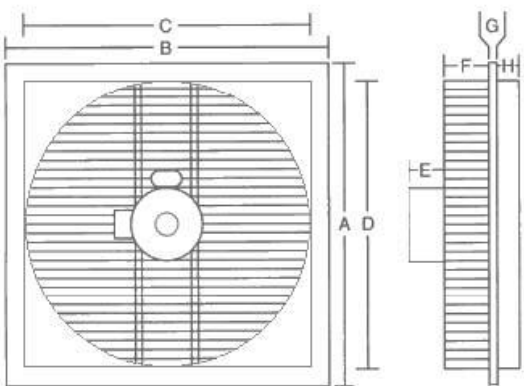

Variable Speed Fan Dimensions

| Fan Size | A | B | C | D | E | F | G | H | Opening Size |
|----------|-----|-----|---------|---------|----|----|------|----|--------------|
| 12" | 15" | 15" | 12 1/8" | 12 1/8" | 6" | 3" | 1/8" | 2" | 12 1/4" sq. |
| 16" | 19" | 19" | 16 1/8" | 16 1/8" | 6" | 3" | 1/8" | 2" | 16 1/4" sq. |
| 20" | 23" | 23" | 20 1/8" | 20 1/8" | 6" | 3" | 1/8" | 2" | 20 1/4" sq. |
| 24" | 27" | 27" | 24 1/8" | 24 1/8" | 6" | 3" | 1/8" | 2" | 24 1/4" sq. |

3 Speed Fan Dimensions

| Fan Size | A | B | C | D | E | F | G | H | Opening Size |
|----------|-----|-----|---------|---------|--------|--------|------|----|--------------|
| 12" | 15" | 15" | 12 1/8" | 12 1/8" | 1 1/2" | 5 1/2" | 1/8" | 2" | 12 1/4" sq. |
| 16" | 19" | 19" | 16 1/8" | 16 1/8" | 2" | 5 1/4" | 1/8" | 2" | 16 1/4" sq. |
| 20" | 23" | 23" | 20 1/8" | 20 1/8" | 2" | 5 1/4" | 1/8" | 2" | 20 1/4" sq. |
| 24" | 27" | 27" | 24 1/8" | 24 1/8" | 2 1/8" | 5 3/4" | 1/8" | 2" | 24 1/4" sq. |

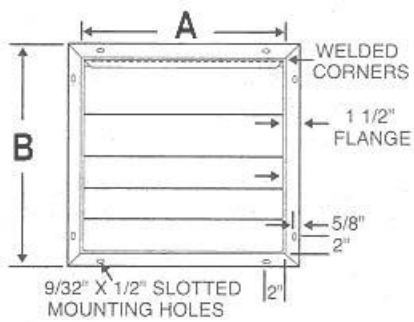

Front View

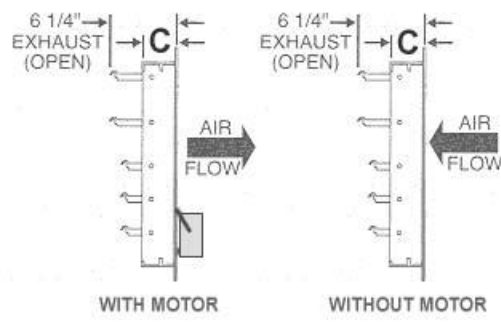

Side View

Intake Shutter Dimensions

| Shutter Size | A | B | C | Opening Size |
|--------------|----------|---------|---------|--------------|
| 12" | 12 1/16" | 15 1/8" | 2 5/16" | 12 1/4" sq. |
| 16" | 16 1/16" | 19 1/8" | 2 5/16" | 16 1/4" sq. |
| 20" | 20 1/16" | 23 1/8" | 2 5/16" | 20 1/4" sq. |
| 24" | 24 1/16" | 27 1/8" | 2 5/16" | 24 1/4" sq. |
| 30" | 30 1/16" | 33 1/8" | 2 5/16" | 30 1/4" sq. |

Intake Motor Installation

General Safety Information

1. Follow all local electrical and safety codes, as well as the National Electrical Code (NEC) and the Occupational Safety and Health Act (OSHA) in the United States.
2. Belimo shutter motors are double insulated, so an electrical ground connection is not necessary.
3. Always disconnect power source before working on or near a motor or its connected load. If the power disconnect point is out-of-sight, lock it in the open position and tag to prevent unexpected application of power.
4. Protect the power cable from coming in contact with sharp objects.
5. Do not kink power cable and never allow the cable to come in contact with oil, grease, hot surfaces, or chemicals.
6. Make certain that the power source conforms to the requirements of your equipment.

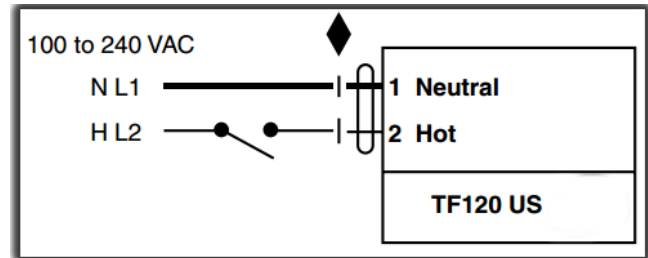

Shutter Motor Installation

1. Fasten motor bracket loosely to shutter frame with two motor plate bolts and nuts.
 2. With shutter closed and motor arm in closed position, loosen adjustable motor arm linkage.
 3. Connect motor arm linkage to tie bar and tighten securely.
 4. Tighten adjustable linkage that was loosened in Step 2 above.
- IMPORTANT:** Linkage bar must be on right side of tie bar.
5. Slide motor plate right or left to align linkage along side tie bar. Tighten motor plate securely to frame.
 6. Determine power supply voltage and wire shutter motor per appropriate wiring diagram. Be sure to insulate the unused lead.
 7. Discard one bolt and nut on aluminum unit.
- NOTE:** Unit not field serviceable and should be replaced as an assembly.

Mounting Motor and Arm Linkage

IMPORTANT NOTES:

1. Motors are fastened to the aluminum shutters with a single nut and bolt. Use the front slot on the motor bracket to mount it to the shutter.
2. Make sure the motor is off and the shutter louvers are completely closed when attaching the arm linkage to the tie bar.
3. The arm linkage section attached to the black shutter motor arm should not have to be adjusted. Only the slider on the arm linkage itself should be adjusted for a snug fit.

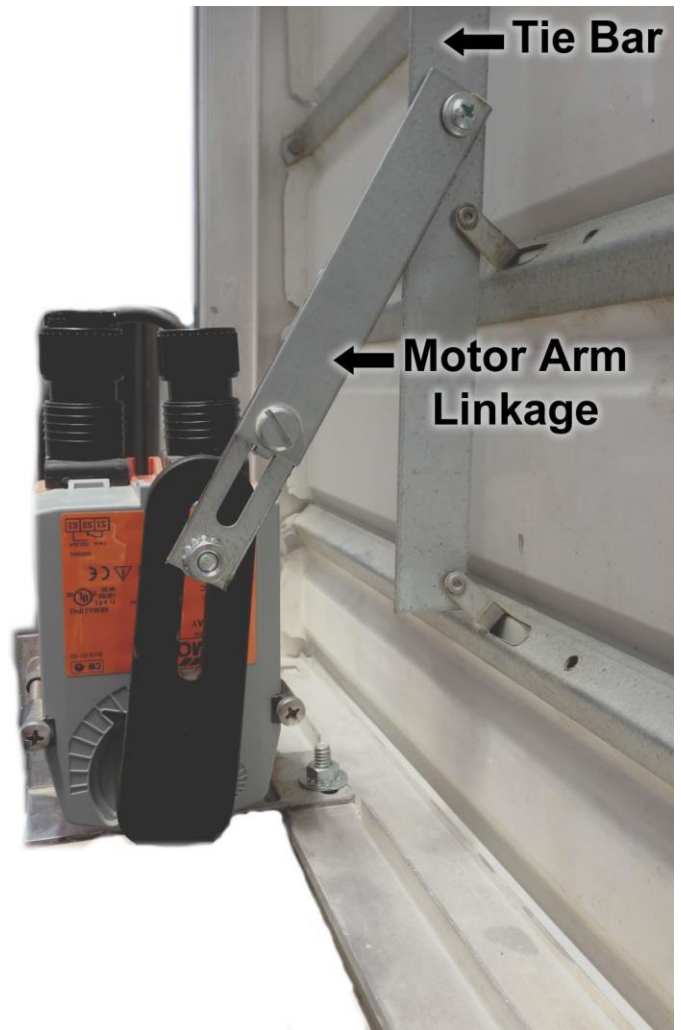

Setting the Rotation Limiter

The rotation limiter controls how far the arm on the shutter motor rotates. It should be set to the highest position to work properly with intake shutters. To do this, take a Phillips head screwdriver, and turn the screw counter clockwise to loosen the limiter screw (shown in picture to the right). Then slide the limiter as far up as it will go. Now tighten the limiter screw by turning it clockwise.



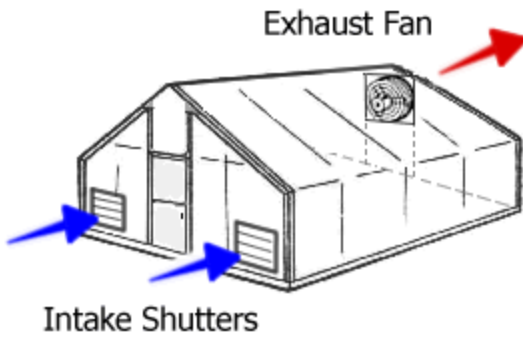

The picture to the left shows optimal fan and shutter placement in a greenhouse. The exhaust fan should be mounted near the peak so that it is exhausting the hottest air in the greenhouse. The intake shutters should be mounted on the opposite end of the greenhouse so that the cooler fresh air travels across the entire structure minimizing hot spots.

Fan & Shutter Installation

1. Select a location on the greenhouse to insert the fan and shutters (optimal placement is shown in above picture).
2. Draw an outline of the area to be cut in the plastic panels. Dimensions for fans and shutters are included with these instructions.
3. Use a drill or a razor to create an opening large enough to insert a fine saw blade inside the outlined area of the wall panel.
4. Cut out the remainder of the outlined area with the saw, and repeat for each shutter and/or fan.
5. Fasten the fan and shutter to the greenhouse frame. **DO NOT** mount the fan to the covering because it will not support the fan's weight. You can make mounting brackets if needed out of 1/8" thick 1" x 1" aluminum angle available at most hardware stores. Drill four holes in the brackets for mounting (2 center holes for fan or shutter and the 2 exterior holes for mounting to your frame).
6. Insert the fan and shutters into the openings cut in the plastic panel and attach the mounting brackets to the greenhouse (shutter motors should be mounted to the shutter before this step). All equipment should be mounted so that the louvers open to the outside of the greenhouse.
7. Seal around where the fan and shutters exit your structure with silicone or caulking designed for the material that the fan equipment is mounted through.



Thermostat & Speed Control Installation

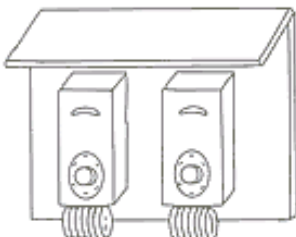

To get the desired temperature, thermostats should be located at plant height near the center of the greenhouse where they are not influenced by drafts or sidewall cooling. It is best if both the thermostat and speed control are located together and protected from direct contact with sunlight and water. One simple way to accomplish this would be to mount the controls to a piece of wood with a top on it like in the picture to the left. Wood should be painted white to shade it from the sun.

WIRING DIAGRAMS:

OPTION 1

Stage 1: Shutters open

Stage 2: Both fans run

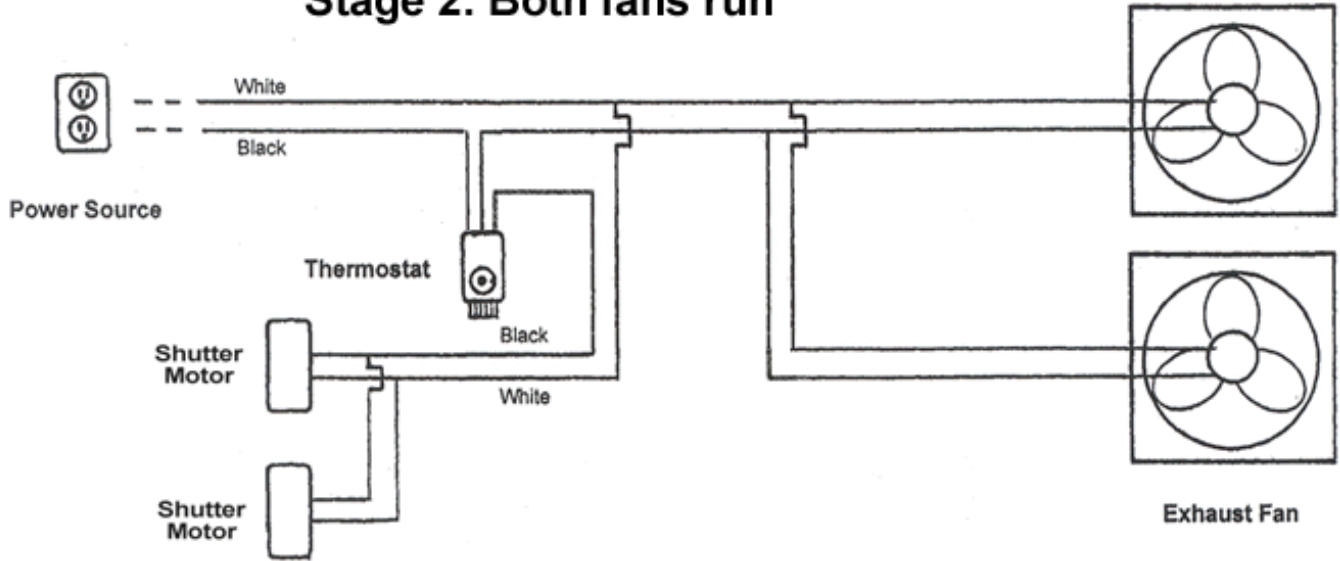

OPTION 2

Stage 1: Shutters open & 1 fan runs

Stage 2: 2nd fan runs

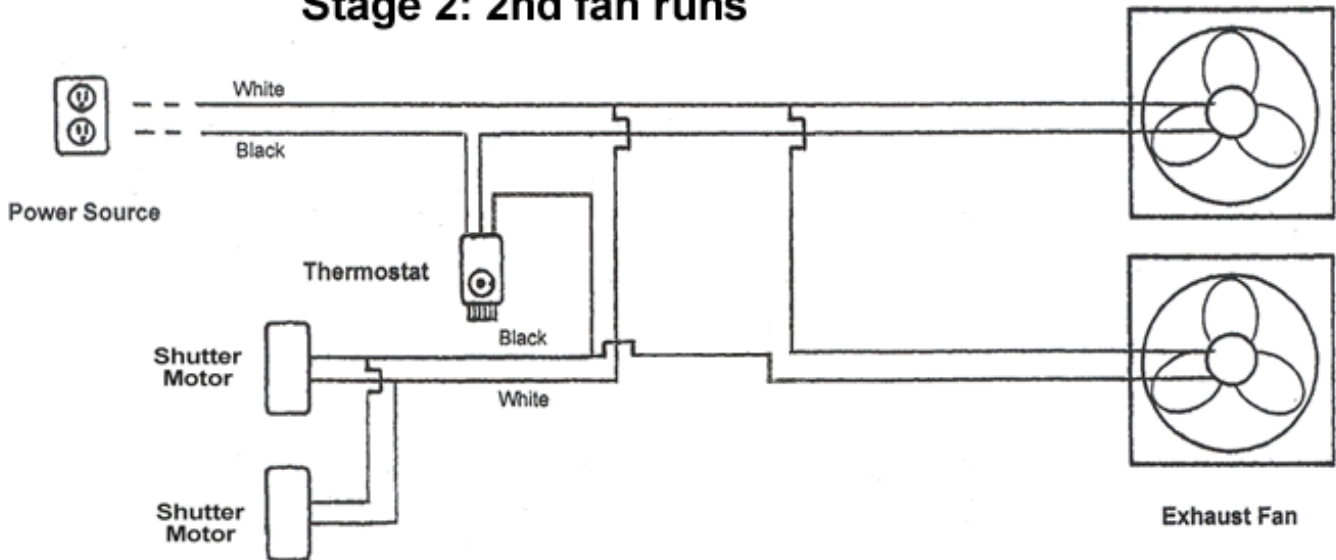

2 Stage Thermostat Wiring

OPTION 1:

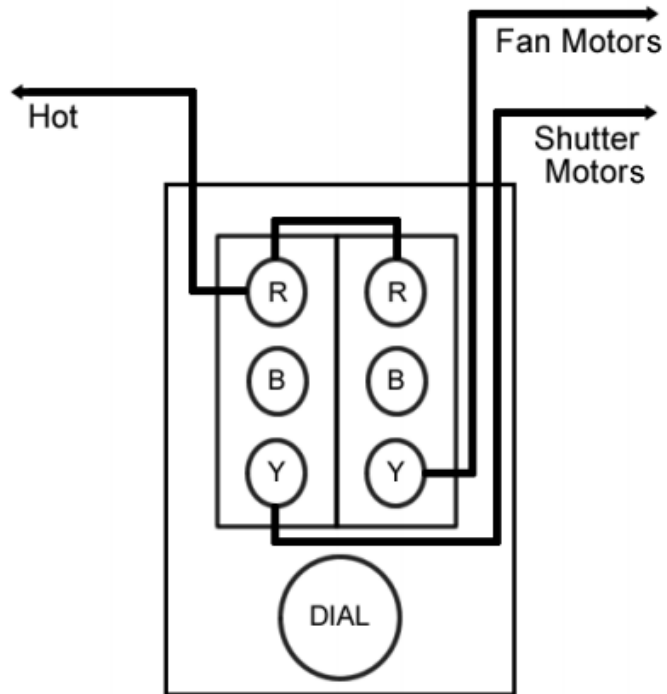

OPTION 2:

