

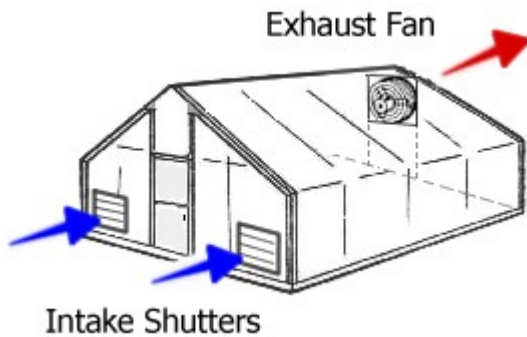

## Elite Plug-in Fan System Installation Guide



The picture to the left shows optimal fan and shutter placement in a greenhouse. The exhaust fan should be mounted near the peak so that it is exhausting the hottest air in the greenhouse. The intake shutters should be mounted on the opposite end of the greenhouse so that the cooler fresh air travels across the entire structure minimizing hot spots.

### Fan & Shutter Installation

1. Select a location on the greenhouse to insert the fan and shutters (optimal placement is shown in above picture).
2. Draw an outline of the area to be cut in the plastic panels. Dimensions for fans and shutters are included with these instructions.
3. Use a drill or a razor to create an opening large enough to insert a fine saw blade inside the outlined area of the wall panel.
4. Cut out the remainder of the outlined area with the saw, and repeat for each shutter and/or fan.
5. Fasten the fan and shutter to the greenhouse frame. **DO NOT** mount the fan to the covering because it will not support the fan's weight. You can make mounting brackets if needed out of 1/8" thick 1" x 1" aluminum angle available at most hardware stores. Drill four holes in the brackets for mounting (2 center holes for fan or shutter and the 2 exterior holes for mounting to your frame).
6. Insert the fan and shutters into the openings cut in the plastic panel and attach the mounting brackets to the greenhouse (shutter motors should be mounted to the shutter before this step). All equipment should be mounted so that the louvers open to the outside of the greenhouse.
7. Seal around where the fan and shutters exit your structure with silicone or caulking designed for the material that the fan equipment is mounted through.

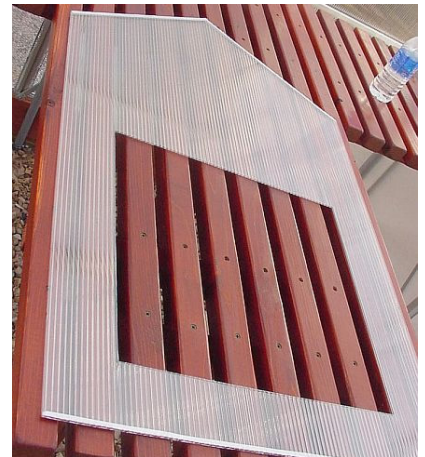

## Exhaust Fan Dimensions

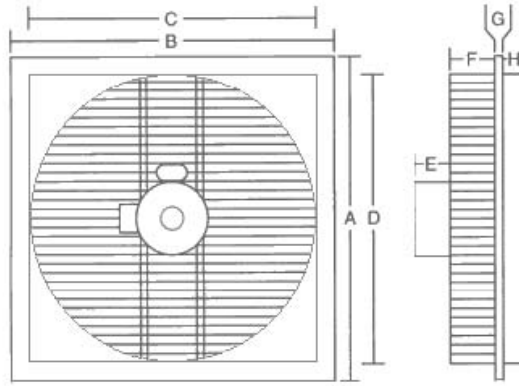

Fan Size	A	B	C	D	E	F	G	H	Opening Size
12"	15"	15"	12 1/8"	12 1/8"	1 1/2"	5 1/2"	1/8"	2"	12 1/4" sq.
16"	19"	19"	16 1/8"	16 1/8"	2"	5 1/4"	1/8"	2"	16 1/4" sq.
20"	23"	23"	20 1/8"	20 1/8"	2"	5 1/4"	1/8"	2"	20 1/4" sq.
24"	27"	27"	24 1/8"	24 1/8"	2 1/8"	5 3/4"	1/8"	2"	24 1/4" sq.

## Intake Shutter Dimensions

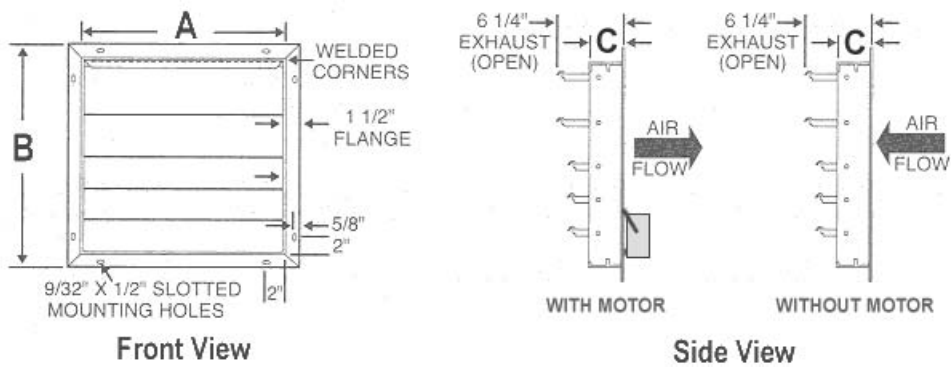

Shutter Size	A	B	C	Opening Size
12"	12 1/16"	15 1/8"	2 5/16"	12 1/4" sq.
16"	16 1/16"	19 1/8"	2 5/16"	16 1/4" sq.
20"	20 1/16"	23 1/8"	2 5/16"	20 1/4" sq.
24"	24 1/16"	27 1/8"	2 5/16"	24 1/4" sq.
30"	30 1/16"	33 1/8"	2 5/16"	30 1/4" sq.

## Mounting Motor and Arm Linkage

### IMPORTANT NOTES:

1. Motors are fastened to the aluminum shutters with a single nut and bolt. Use the front slot on the motor bracket to mount it to the shutter.
2. Make sure the motor is off and the shutter louvers are completely closed when attaching the arm linkage to the tie bar.
3. The arm linkage section attached to the black shutter motor arm should not have to be adjusted. Only the slider on the arm linkage itself should be adjusted for a snug fit.

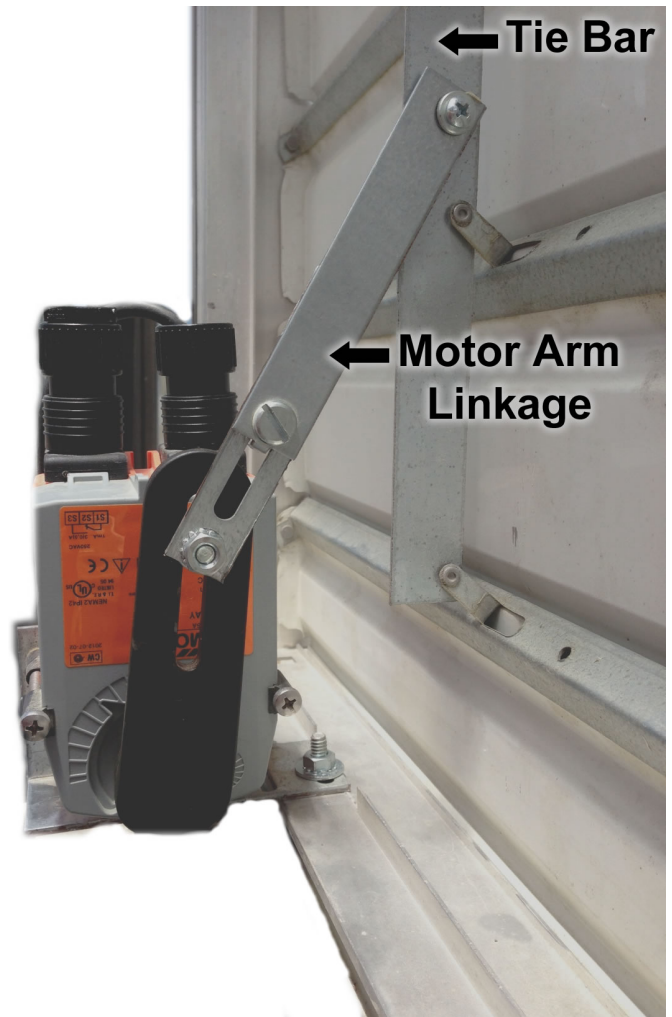

## Setting the Rotation Limiter

The rotation limiter controls how far the arm on the shutter motor rotates. It should be set to the highest position to work properly with intake shutters. To do this, take a Phillips head screwdriver, and turn the screw counter clockwise to loosen the limiter screw (shown in picture to the right). Then slide the limiter as far up as it will go. Now tighten the limiter screw by turning it clockwise.



# Plugging Everything In

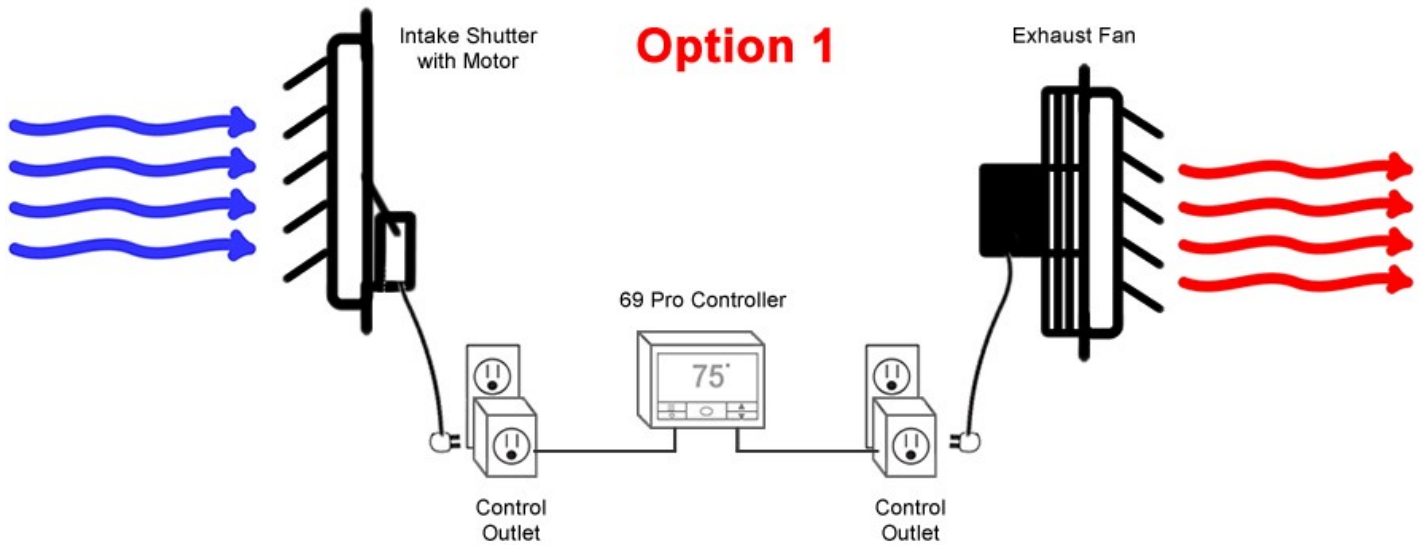

**or**  
**Option 2**

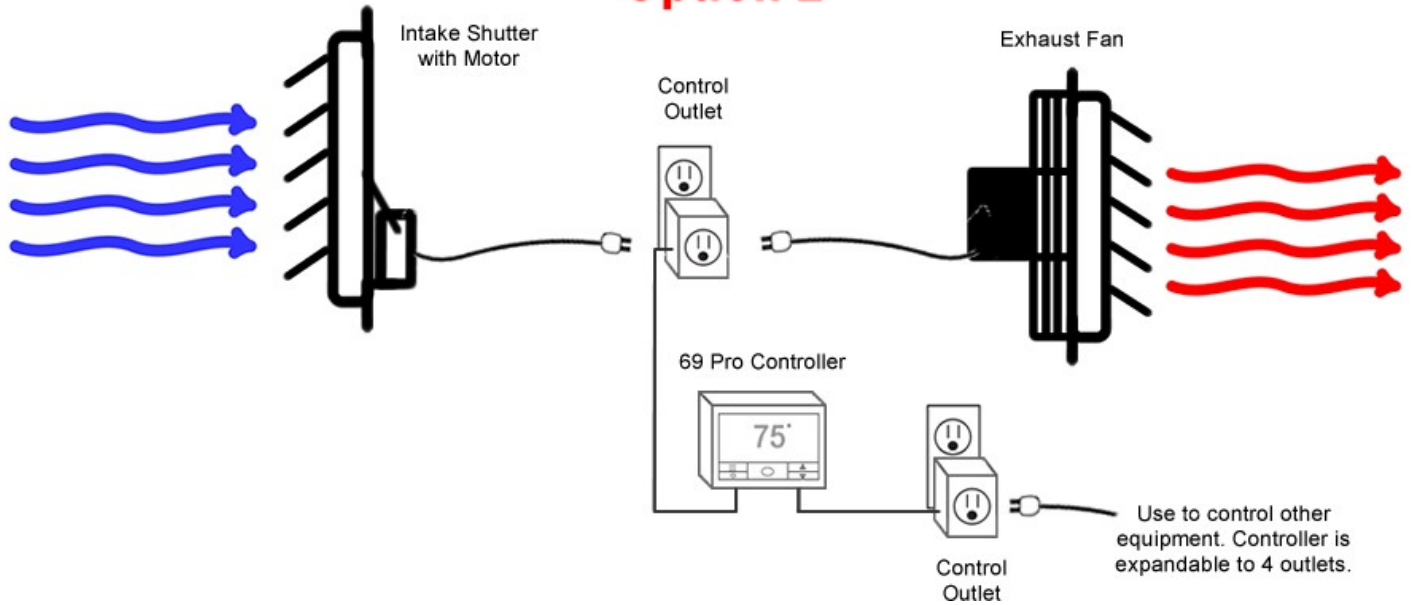

The included multi-outlet adapter can be used to plug multiple devices into a single control outlet (left picture below) or to plug multiple control outlets into a single power outlet (right picture below).





# AC Infinity 69 PRO Control System Setup Guide

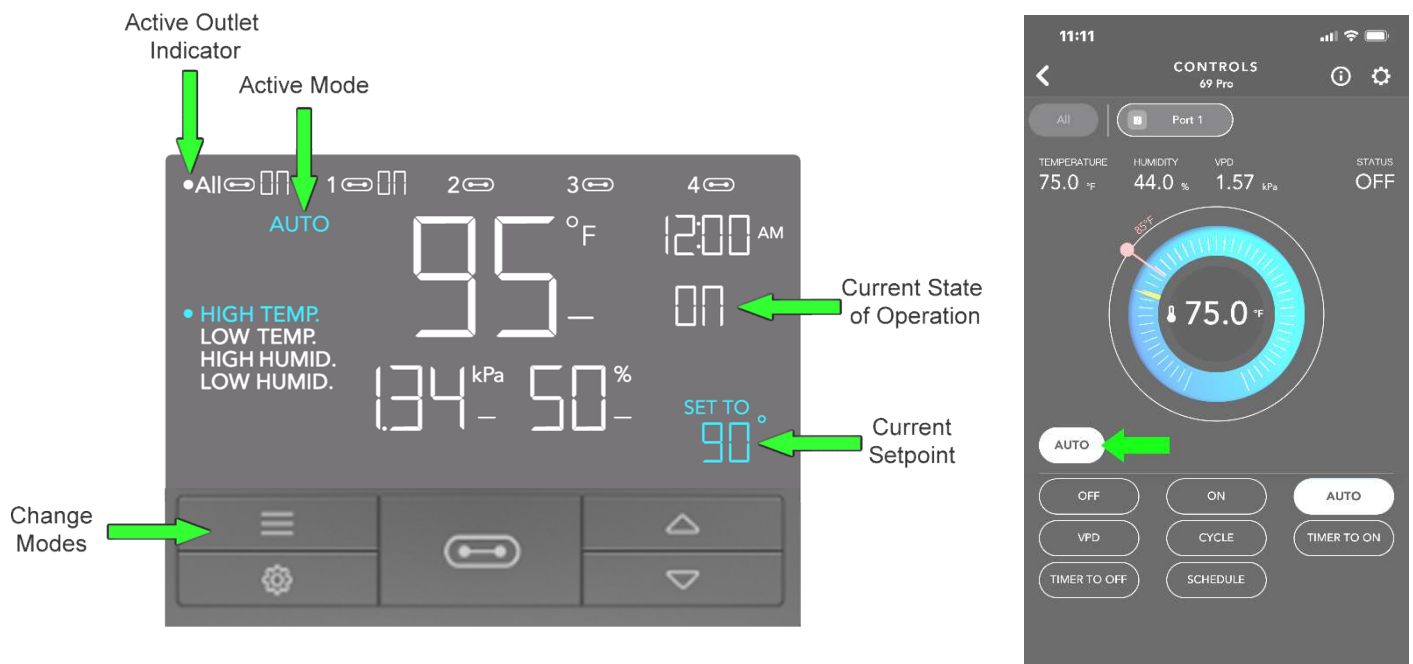

## Automating Your Devices Based on Temperature and/or Humidity

AUTO is the most commonly used mode. It is where you setup automation of your device(s) by temperature (cooling and heating devices) and/or humidity (misting, fogger, humidifier).

1. Press the mode button until the screen shows AUTO at the top left. The picture above to the left shows what the screen of your controller should resemble when in AUTO mode.
2. Continue pressing the mode button to select the desired AUTO mode (see below for mode details).
3. Use the UP and DOWN arrows to change the current setpoint.

When using the phone app,

1. Press the mode button highlighted in the picture above to the right.
2. Then select AUTO from the menu. You can now enable / setup triggers for the mode you want using the touchscreen.

### AUTO MODES

HIGH TEMP - Cuts device ON when temperature rises above the setpoint. Used for cooling.

LOW TEMP - Cuts device ON when temperature drops below the setpoint. Used for heating.

HIGH HUMID – Cuts device ON when humidity rises above the setpoint. Used for dehumidifying.

LOW HUMID – Cuts device ON when humidity drops below the setpoint. Used for humidifying.

Although you can activate more than one of the modes above at the same time, only one mode is used at a time for most applications. One instance where multiple modes could be used is if you want an exhaust fan system to come on when the temperature and/or humidity get too high in the greenhouse. In this scenario, you would set both HIGH TEMP and HIGH HUMID setpoints. Then the fan system would come on if either setpoints are triggered.

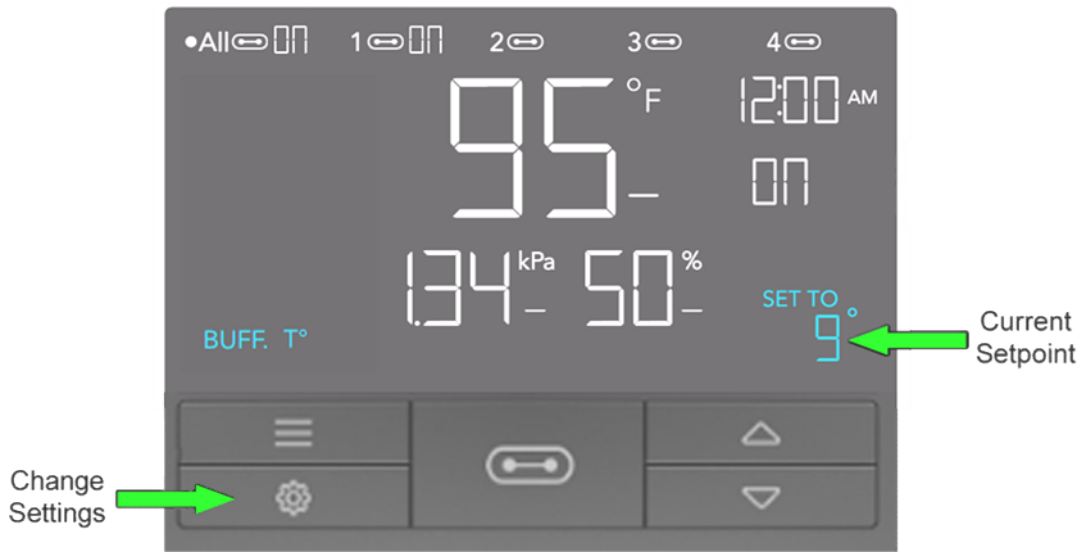

Now that you have selected your mode and set the desired setpoint, you will want to create buffer settings for temperature and/or humidity.

1. Press the settings button until you reach the desired setpoint to change (Temperature in the picture above to the left).
2. Then use the UP and DOWN buttons to select the desired setpoint. A minimum setting of 5 is recommended for either a temperature or humidity buffer in a greenhouse to reduce on/off cycling due to frequent fluctuation.

When using the phone app,

1. Press the change settings button in the top right corner of the screen (shown in picture below to the left) to take you the SETTINGS page (shown in the picture below the right).
2. Select the PORT tab, and choose the port you want to setup.
3. Press the – and + buttons to set buffer.

