

GROW MORE Greenhouses

Assembly Instructions

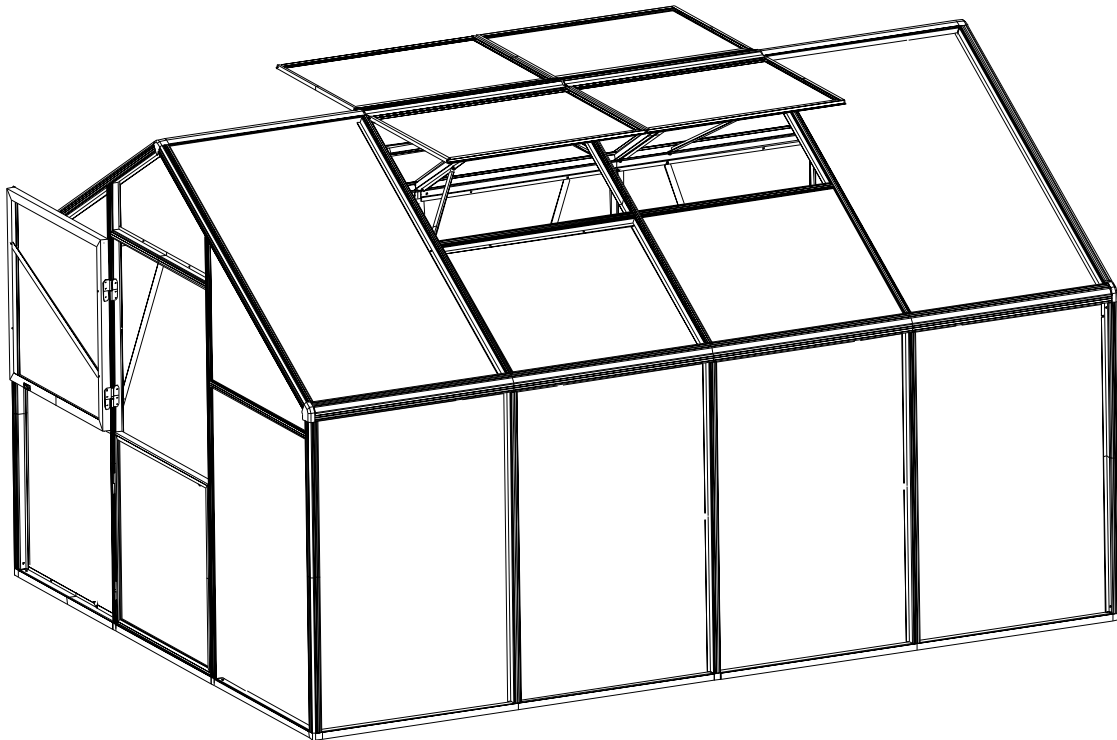

MODEL: GM10

GREENHOUSE SIZE: 13' 3 7/8" L x 10' 1/2" W x 8' H
406cm L x 306cm W x 243cm H

EXTENSION SIZE: 6' 6 3/4" L x 10' 1/2" W x 8' H
200cm L x 306cm W x 243cm H

PLEASE READ INSTRUCTIONS CAREFULLY BEFORE ASSEMBLY

Item No.	Model No.	Packing List				
		AL No.1	AL No.2	AL No.3	PC No.1	PC No.2
2553100	GM10	1CTN <input type="checkbox"/>	1CTN <input type="checkbox"/>		1CTN <input type="checkbox"/>	2CTNS <input type="checkbox"/>
2553150	GM10 ext			1CTN <input type="checkbox"/>		1CTN <input type="checkbox"/>

CONTENTS

1. Assembly Advice	Page 1
2. Product Features	Page 1 - 2
3. Parts List	Page 3 - 6
5. Base Assembly	Page 7 - 10
6. Door Assembly	Page 11 - 12
7. Roof Vent Assembly	Page 13
8. Framework & Panel Assembly	Page 14-30

Assembly and Maintenance Advice

1. For safety purposes, we strongly recommend that this product is assembled by at least two people.
2. Some components have sharp metal edges. Please be careful when handling metal components. Please wear gloves, shoes and safety goggles during assembly.
3. Lay all of the components on a soft carpet or blanket to avoid any scratches or damages.
4. DO NOT climb or stand on the roof. Heavy articles should not be leaned against the greenhouse.
5. Keep the roof and gutter clear of snow, dirt & leaves. Allowing snow to build up on the roof may damage the product.
6. Unlike steel, if the paint finish is scratched this will not harm the aluminium underneath.
7. When your product needs cleaning, use a mild detergent solution and rinse with cold clean water. Do not use acetone, abrasive cleaners or strong detergents to clean the panels.

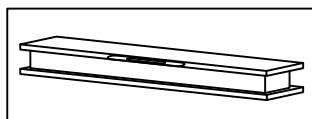
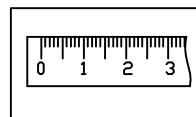
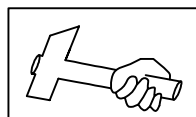
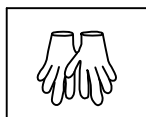
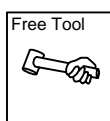
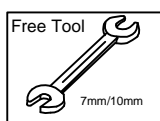

Functions and Features:

1. Compared with traditional greenhouses this exciting product features many significant improvements. The hollow box profile aluminium framing is much stronger than other greenhouses and it can withstand much greater pressure.

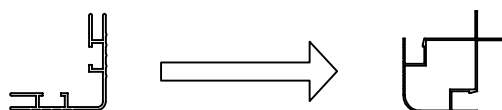

2. Easy and fast assembly.

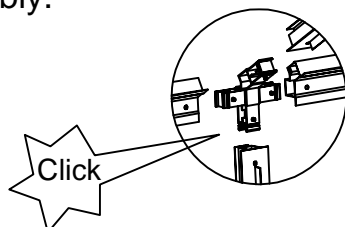

3. The strong two part eaves beam includes an integral gutter. Downpipes are also included as standard so you can collect rainwater.

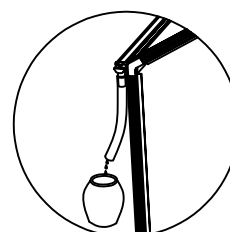

- The greenhouse can be easily extended at any stage in 2m long sections as detailed in the table of Front Page.
- Base anchor brackets are included as standard with expanding bolts to ensure a secure fixing into concrete or paving. Alternatively, you can use the brackets to fix into a timber base with wood screws (not provided).

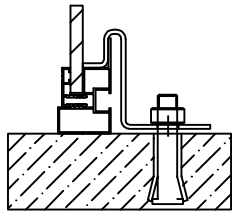

Expansion bolt in concrete

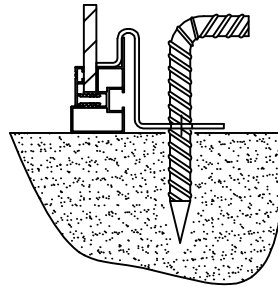

Steel pegs in soil

- Manual window handles are included as standard with the roof vents. If required, automatic roof vent openers are available as an inexpensive optional extra.

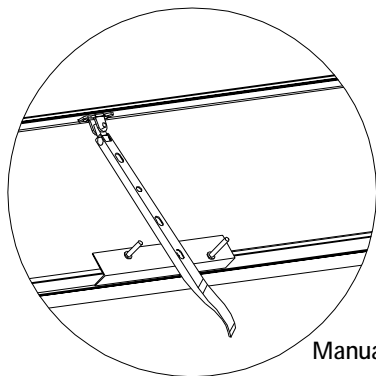

Manual opener

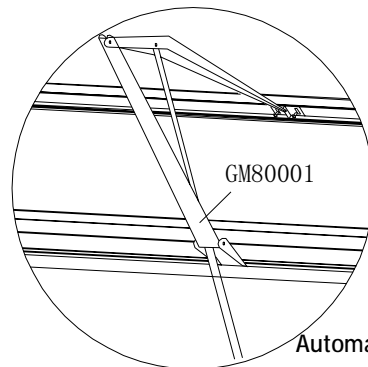





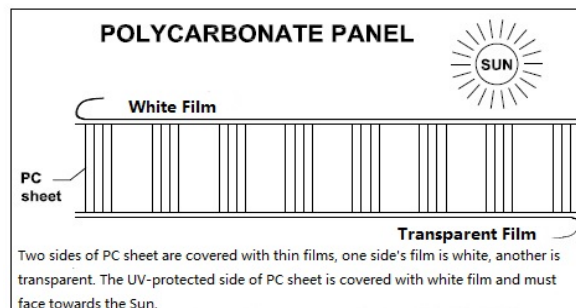





Automatic opener

- Please ensure the roof vents are not installed into the end roof bays of the greenhouse as this is where you need the bracing.
- Each Polycarbonate Panel comes with UV protected properties. Therefore, please ensure the white film is facing outward towards the sun (remove the film before installing into aluminium channel).





























ALU. BOX No. 1



























Door Assembly

PART	NO.	QTY.
	L18A	2
	L18B	2
	L18C	1
	L16A	1
	L16B	1
	L16C	1
	L05G	4
	J	8
	S01 M6X10	8
	M01 M6	8
	Z01 φ5X15	16

Front Wall Assembly

PART	NO.	QTY.	PART	NO.	QTY.	PART	NO.	QTY.
	L01A	1		A	1		W05	2
	L01B	1		B	1		S03 M8X60	2
	L01C	1		C	2		J03R/L	1/1
	L01D	1		D	1		J04	2
	L03E	1		E	1		J01	1
	L03F	1		F	1		J02R/L	1/1
	L04A	1		W01	2		J08	2
	L04B	2		S01 M6X10	18			
	L05A	2		M01 M6	18			
	L08A	3		Z02 φ4X16D	6			

Rear Wall Assembly



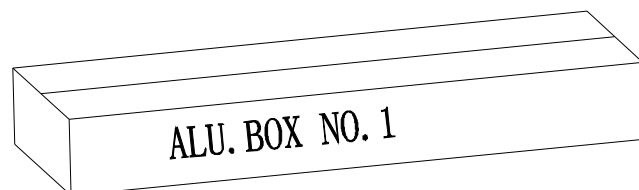























PART	NO.	QTY.	PART	NO.	QTY.	PART	NO.	QTY.
	L01A	2		A	1		Z02 φ4X16D	6
	L01B	1		B	1		W05	3
	L01C	1		C	2		S03 M8X60	3
	L03C	1		D	1		J03R/L	1/1
	L03D	1		E	1		J04	2
	L04B	3		F	1		J01	1
	L05A	2		W01	2		J02R/L	1/1
	L05B	1		S01 M6X10	20		J08	2
	L08A	3		M01 M6	20			















ALU. BOX No. 2

2X2 Sections Assembly

Middle Section Assembly





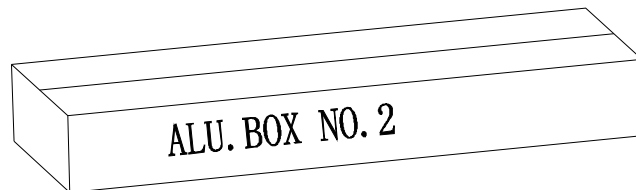





















PART	NO.	QTY.	PART	NO.	QTY.
	L02A	4		W06	8
	L02B	4		W08	4
	L05B	4		W08A	4
	L05C	4		S01 M6X10	76
	L05D	4		S02 M6X16	8
	L06	2		M01 M6	84
	L07	4		Z02 φ4X16D	24
	L08B	4		Z03 φ5X30	16
	L09	4		Z04 φ4X10	16
	L15A	4		W05	8
	L19	8		S03 M8X60	8
	L20	4			
	L21	4			
	L04E	4			
	L22	6			

PART	NO.	QTY.
	L03A	2
	L03B	2
	L05E	2
	L05F	4
	C	2
	G	2
	H	1
	S01 M6X10	6
	M01 M6	6
	J04	2
	J05	1
	J06	2















ALU. BOX No. 3

1X2 Sections Assembly

PART	NO.	QTY.	PART	NO.	QTY.
	L02A	2		W06	4
	L02B	2		W08	2
	L05B	2		W08A	2
	L05C	2		S01 M6X10	38
	L05D	2		S02 M6X16	4
	L06	1		M01 M6	42
	L07	2		Z02 φ4X16D	12
	L08B	2		Z03 φ5X30	8
	L09	2		Z04 φ4X10	8
	L15A	2		W05	4
	L19	4		S03 M8X60	4
	L20	2			
	L21	2			
	L04E	2			
	L22	3			

Middle Section Assembly

PART	NO.	QTY.
	L03A	2
	L03B	2
	L05E	2
	L05F	4
	C	2
	G	2
	H	1
	S01 M6X10	6
	M01 M6	6
	J04	2
	J05	1
	J06	2

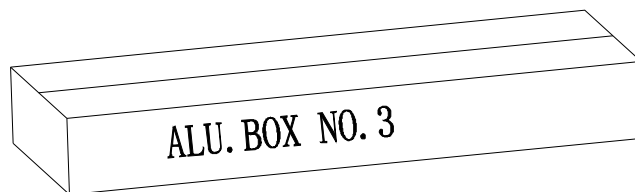





PC Box No. 1





Door Assembly

PART	NO.	QTY.
	Y11	2

Front Wall Assembly

PART	NO.	QTY.
	Y1	1
	Y2	2
	Y4	1
	Y5	1



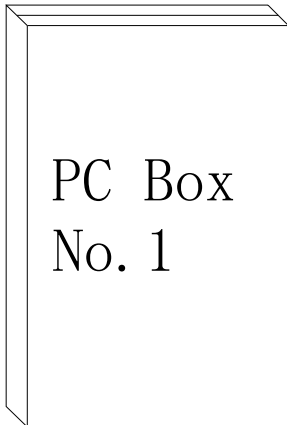

Rear Wall Assembly

PART	NO.	QTY.
	Y1	1
	Y2	3
	Y4	1
	Y3	1



PC Box No. 2

1X2 Sections Assembly

PART	NO.	QTY.
	Y6	4
	Y7	2
	Y9	2
	Y10	2

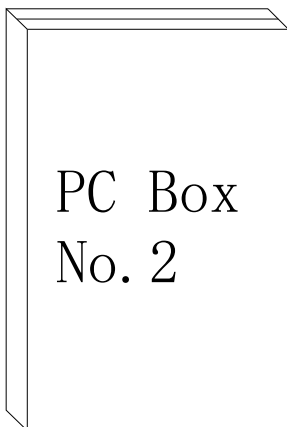

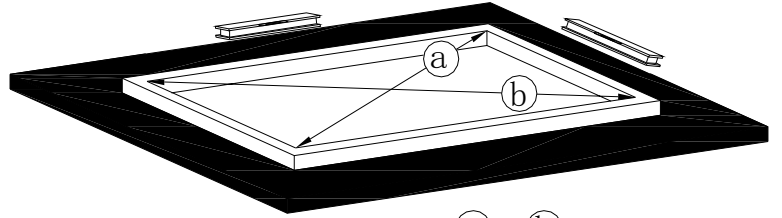
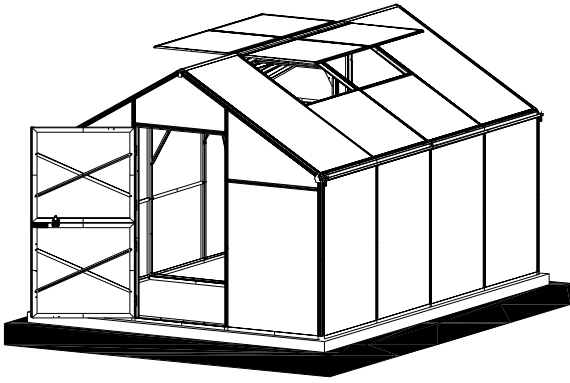

$a = b$

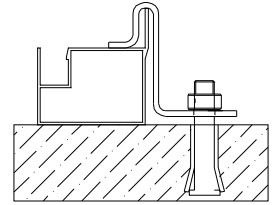
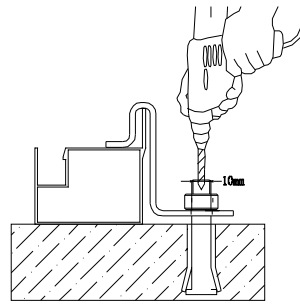

Expansion bolt in concrete

It is essential the dimensions $a + b$ are the same to ensure the base is square.

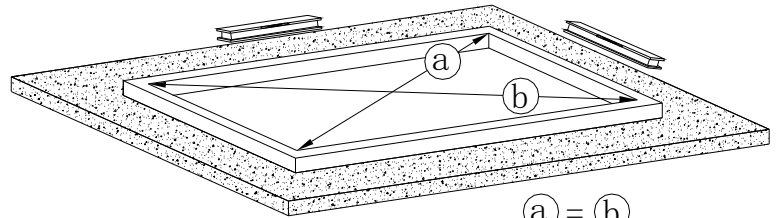
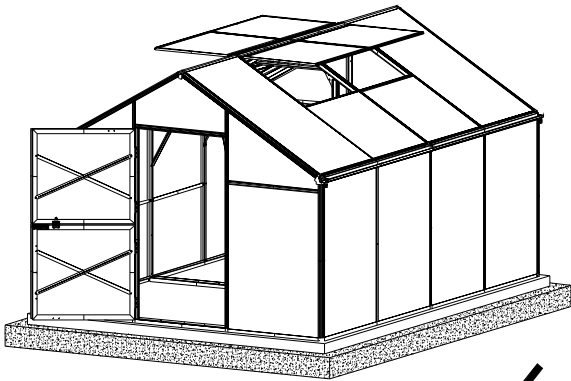

$a = b$

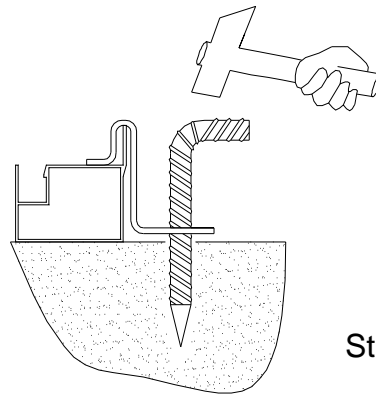

Steel pegs in soil

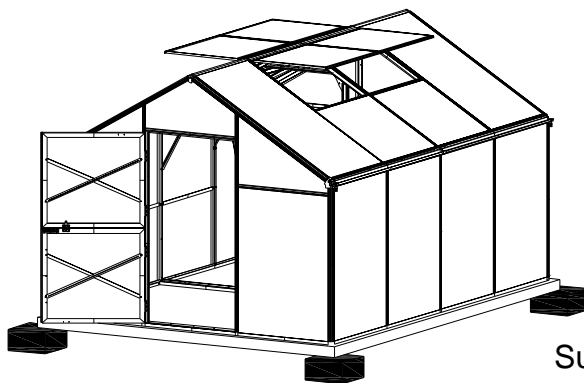

Support at the corners only is inadequate.



GM10

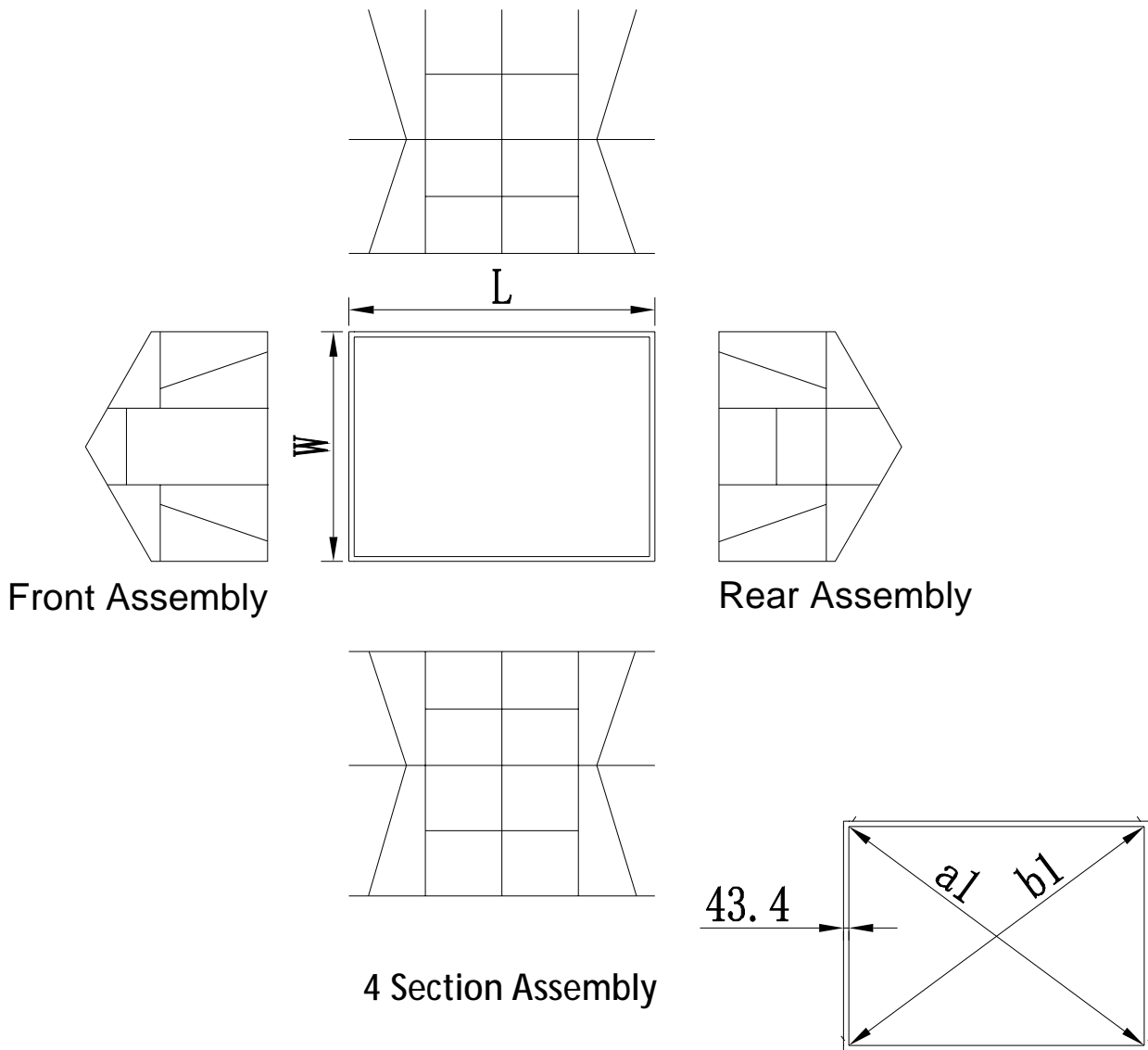

Dim/Model	GM10	GM10+Ext (1)	GM10+Ext (2)	GM10+Ext (3)	GM10+Ext (4)	GM10+Ext (5)	etc.
W (mm)	3059.6	3059.6	3059.6	3059.6	3059.6	3059.6	
L (mm)	4060.2	6062.2	8064.2	10066.2	12068.2	14070.2	
a=b (mm)	5083.9	6790.5	8625.1	10520.9	12450	14399	
a1=b1(mm)	4958.9	6670.7	8510.2	10409.7	12341.7	14293.1	

- * W= Outer Width of Base Profiles
- * L= Outer Length of Base Profiles
- * a=b= Outer Diagonal of Base Profiles
- * a1=b1= Inner Diagonal of Base Profiles

GM10 + Ext(1)

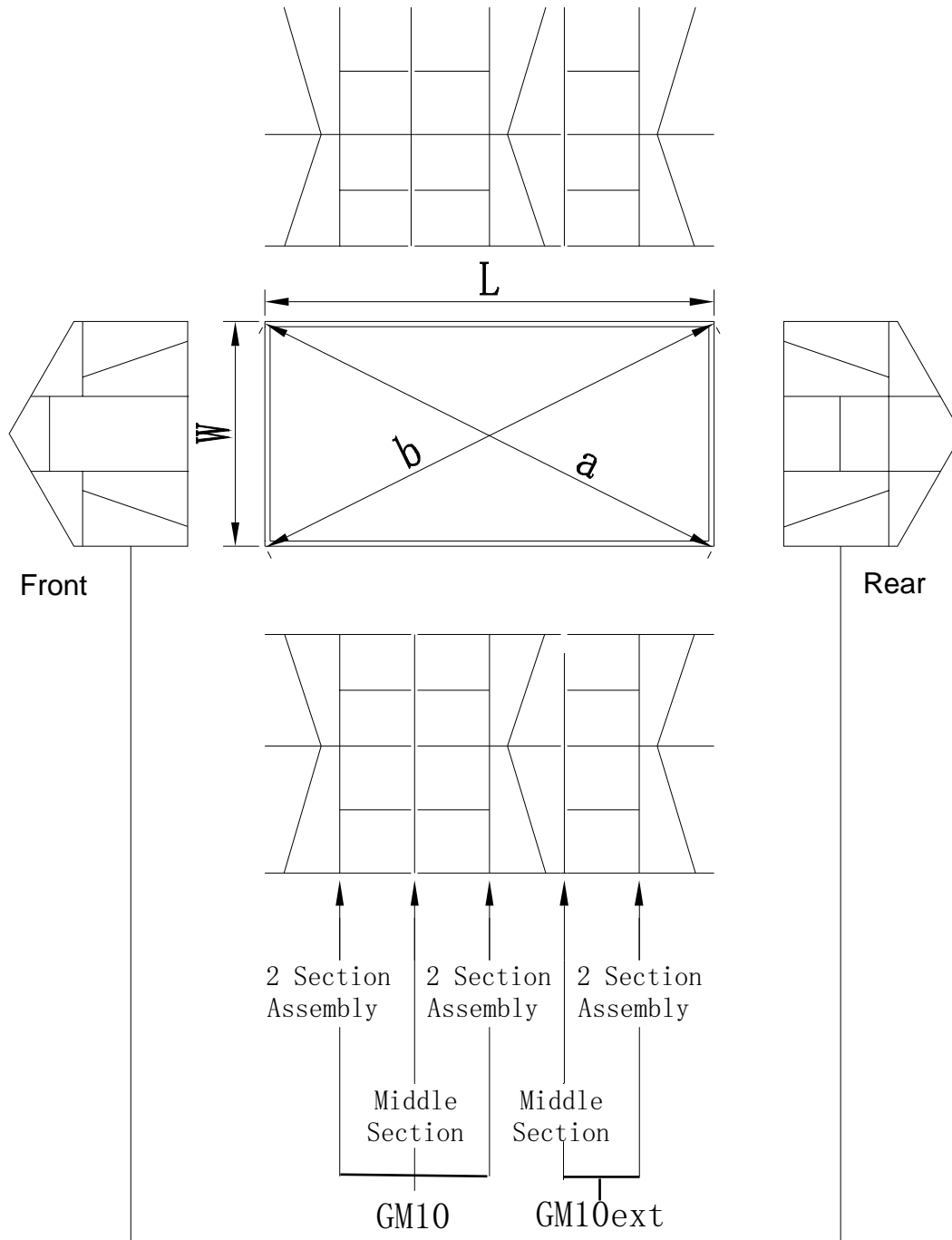



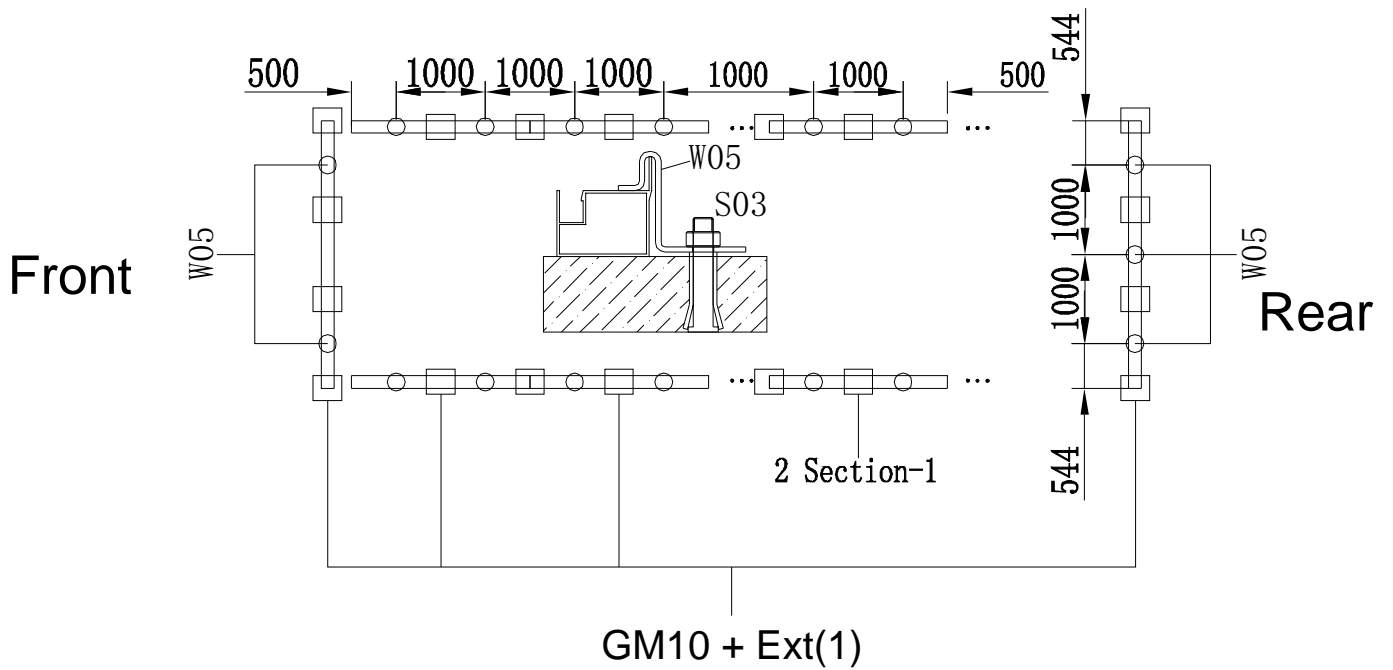









* The basic model, GM10, can be easily extended by adding a '2 Section Assembly' each time for a longer size



* This shows a layout for W05's positions where it is placed in the middle of PC panel for each section.

* All measurements in above diagram are in mm.

PART	NO.	QTY.
	L18A	2
	L18B	2
	L18C	1
	L16A	1
	L16B	1
	L16C	1
	L05G	4
	J	8
	S01 M6X10	8
	M01 M6	8
	Z01 Ø5X15	16
	Y11	2

Door 1 Assembly

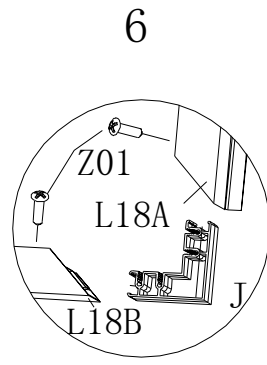
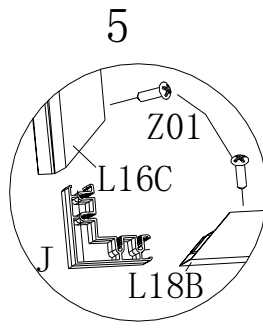
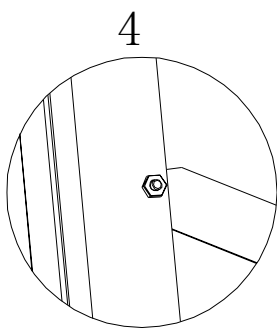
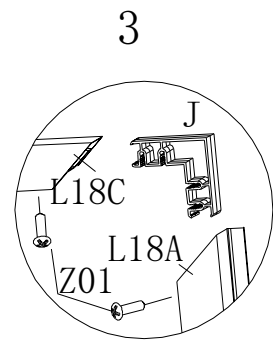
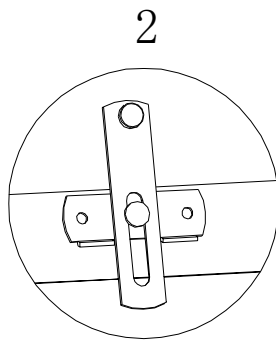
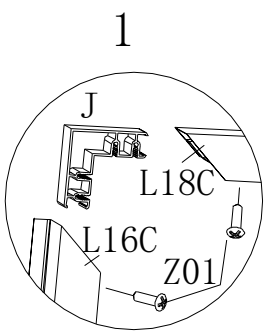
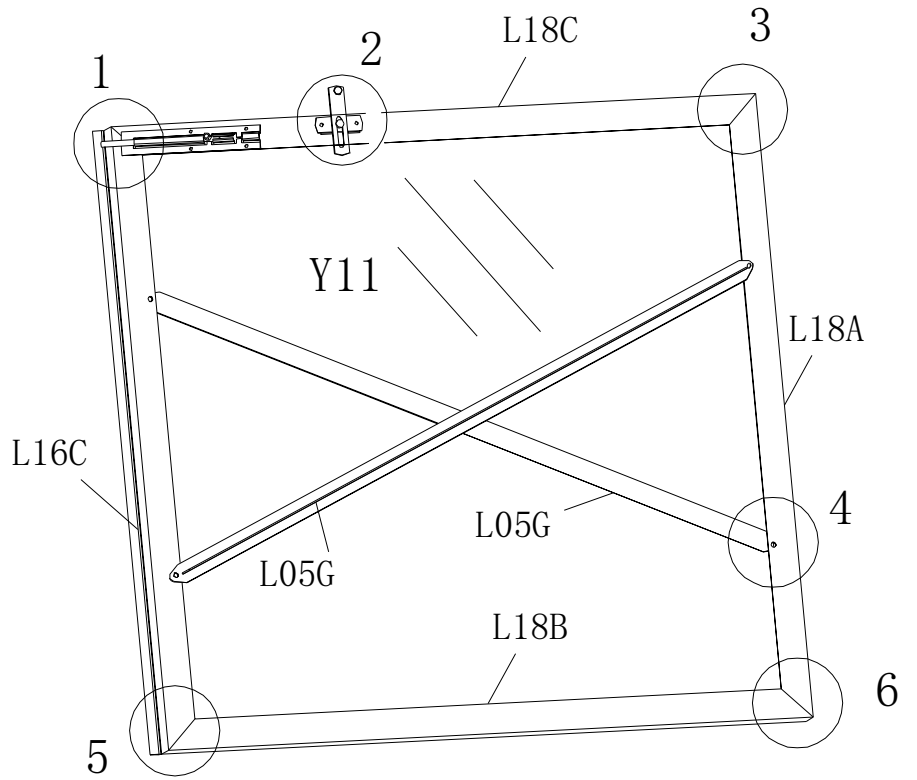

Door 2 Assembly

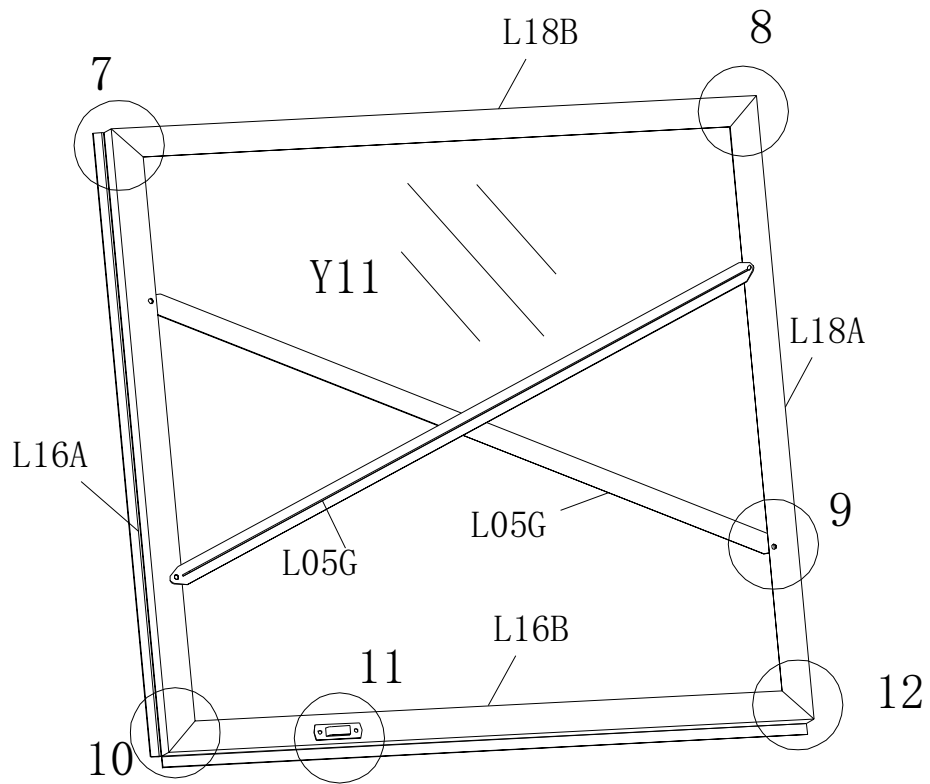

7

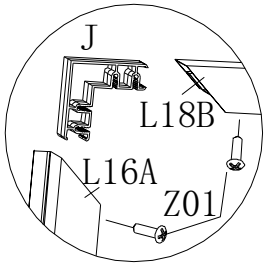

8

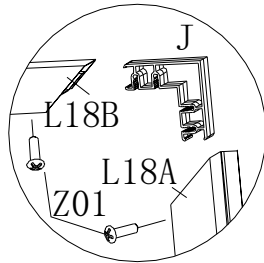

9

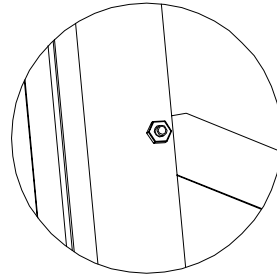

10

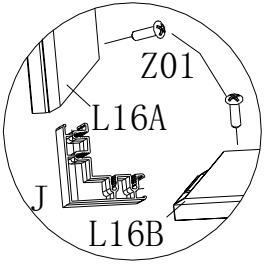



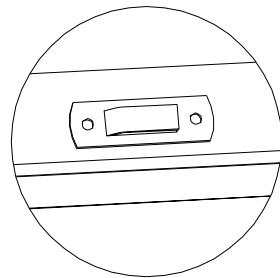



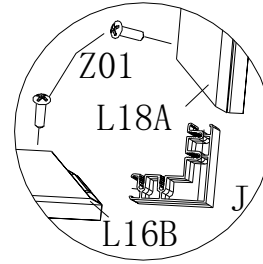

11



12



PART	NO.	QTY.
	L15A	1
	L19	2
	L20	1
	L21	1
	W06	4
	S02	2
	M6X16	
	M01	2
	M6	
	Z02	6
	φ4X16D	
	Z04	4
	φ4X10	

Roof Vent Assembly

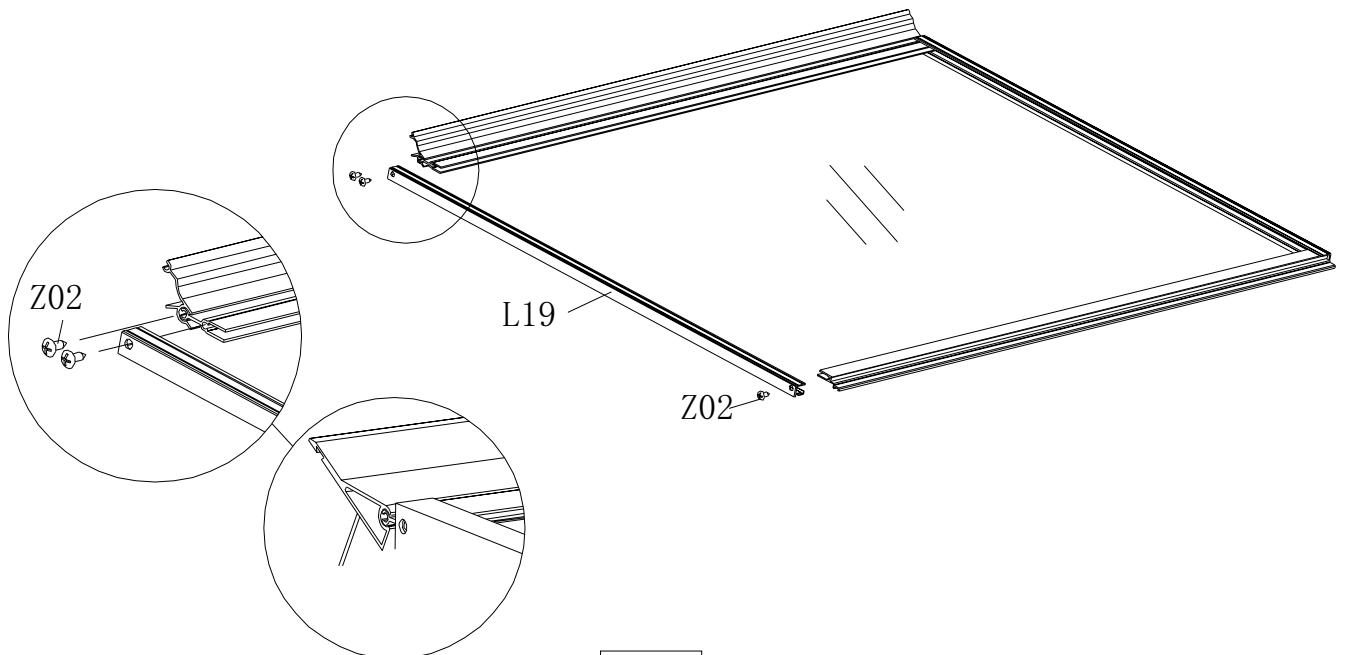
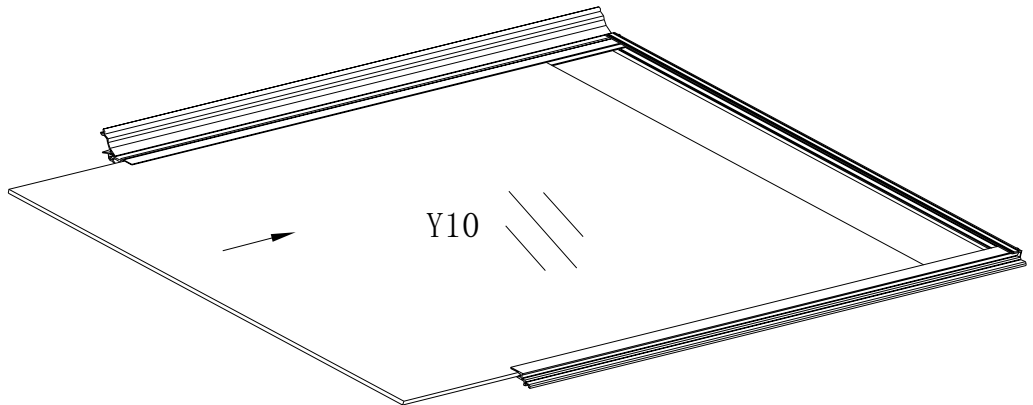
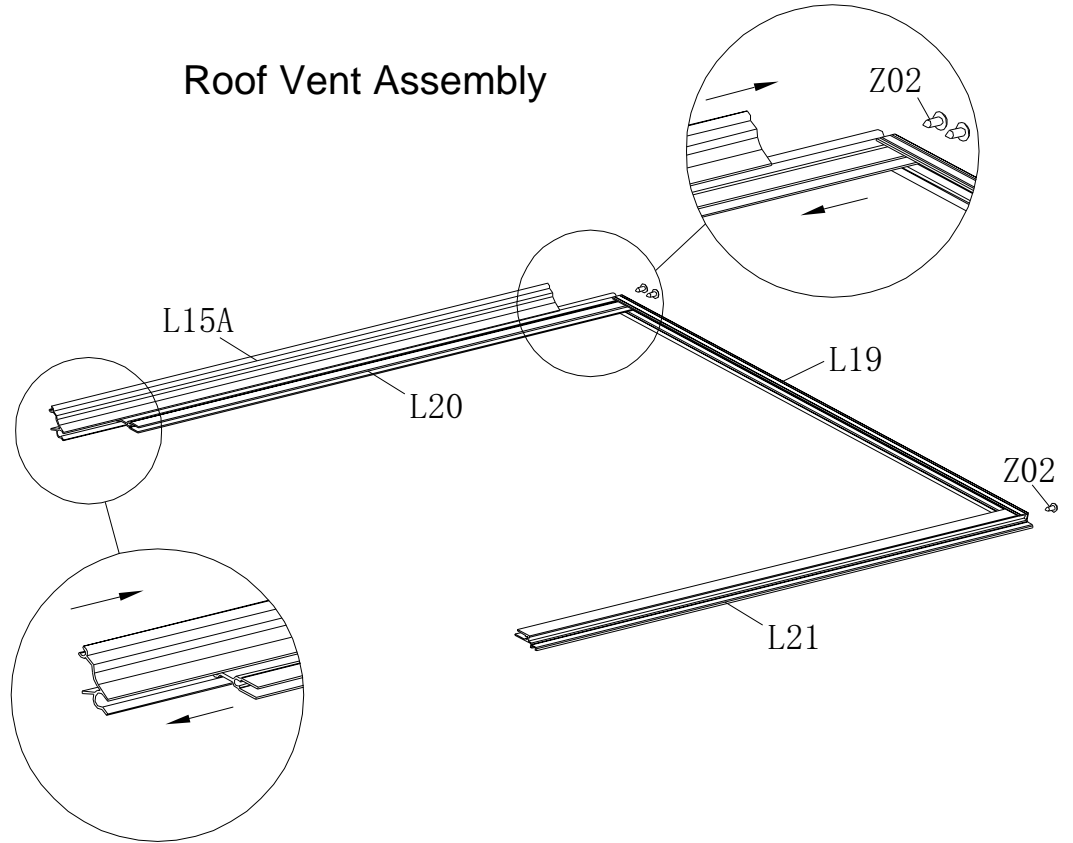

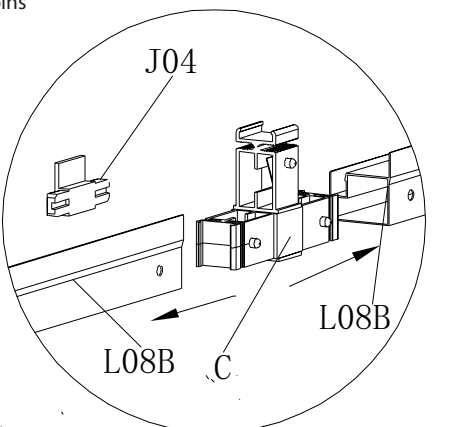
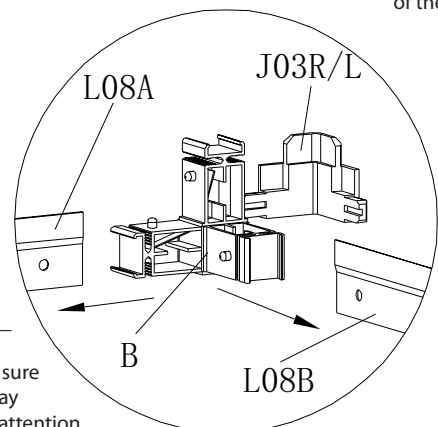
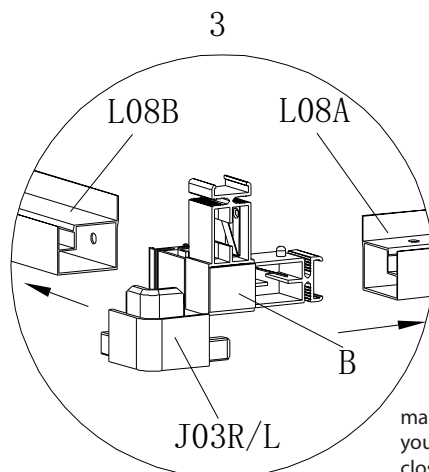
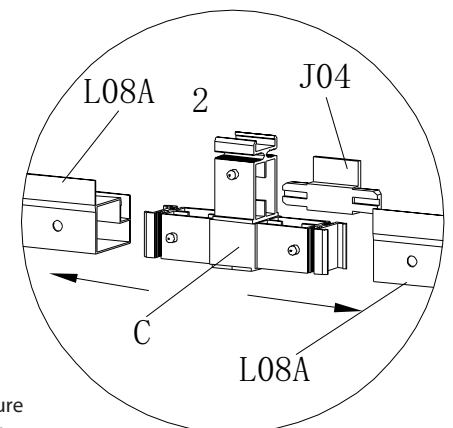
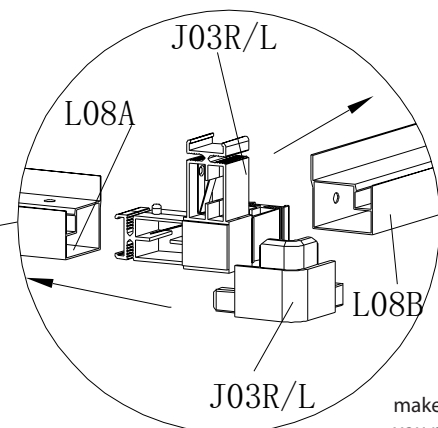
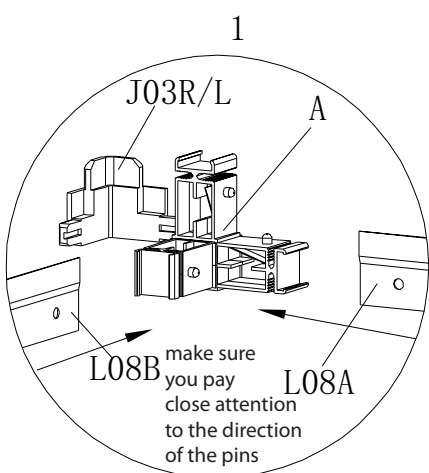
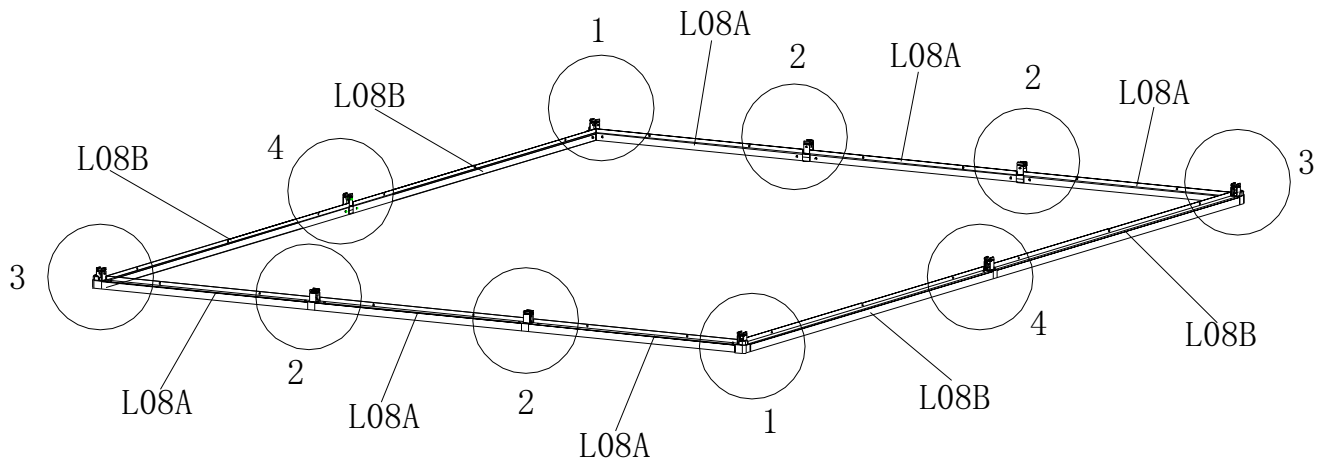

must connect all plastic parts (J04 and J03 R/L) before completing this step

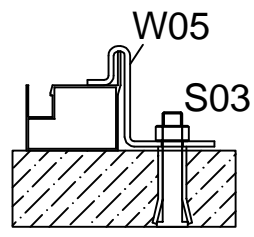

Assemble all W05 followed by previous Page 14 after each base profile is connected.

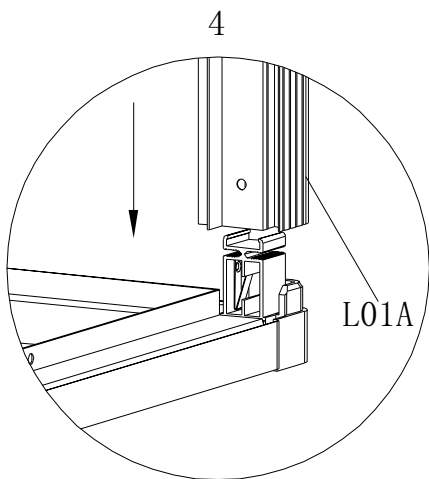
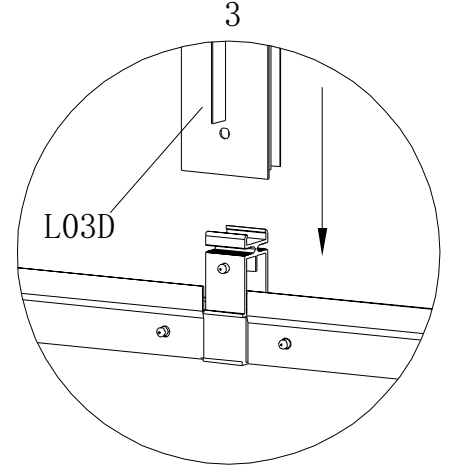
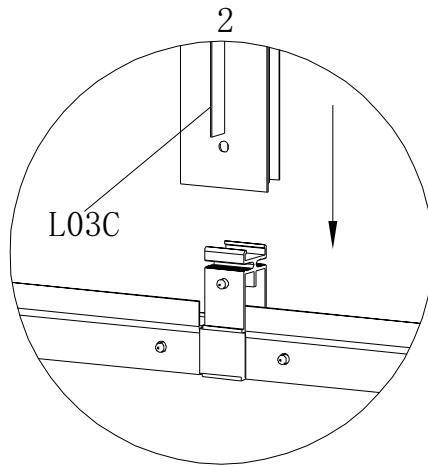
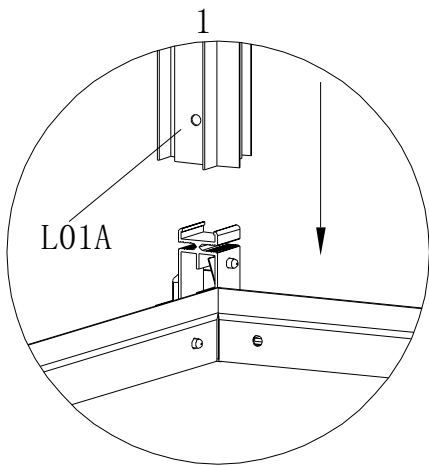
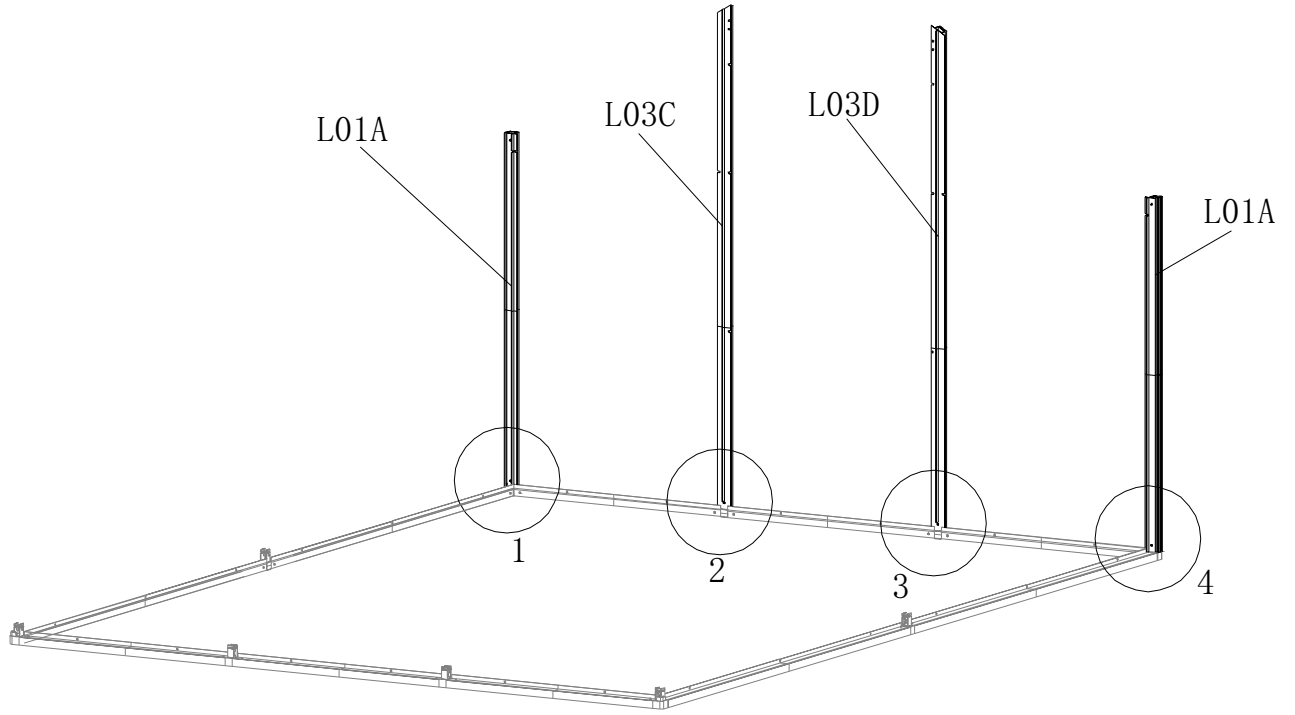

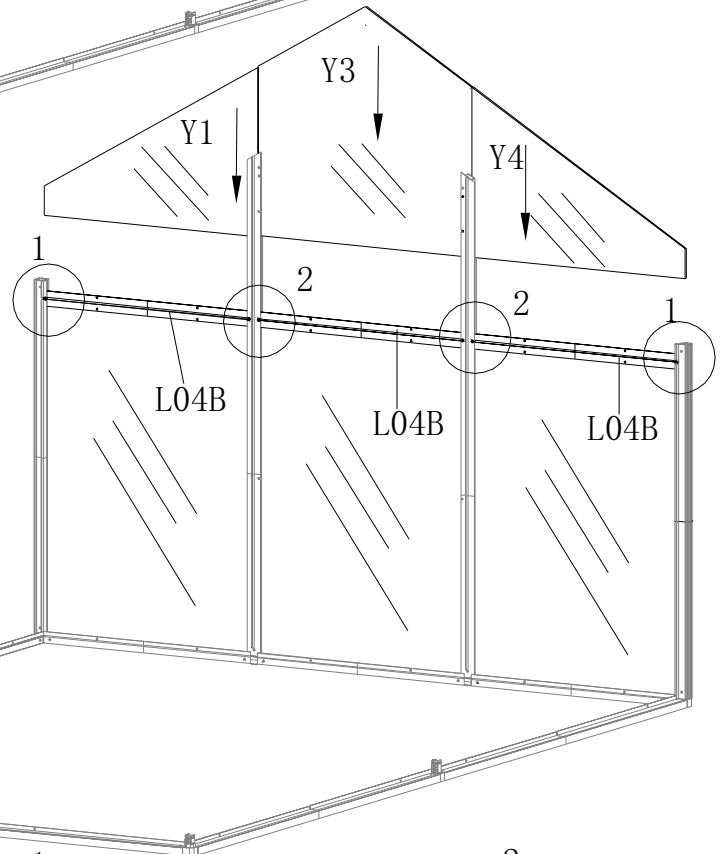
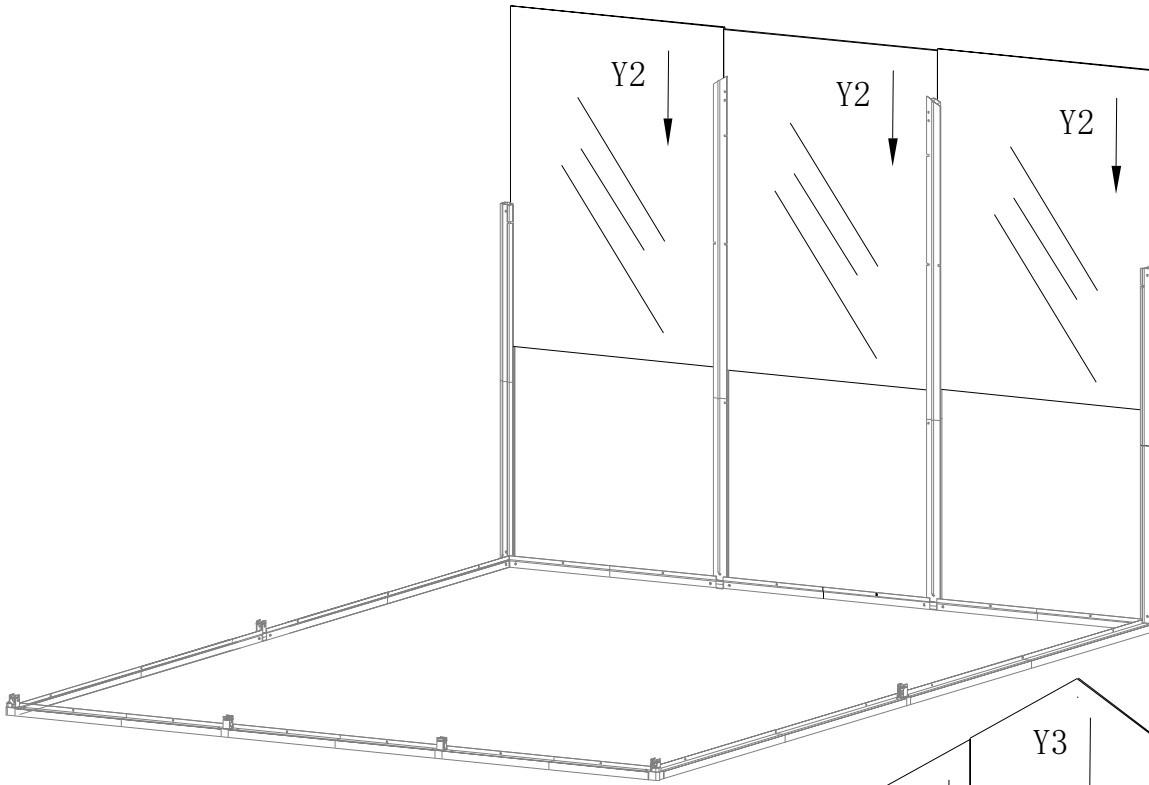

Slide 2*S01 into L04B, and tighten L04B at each end with S01

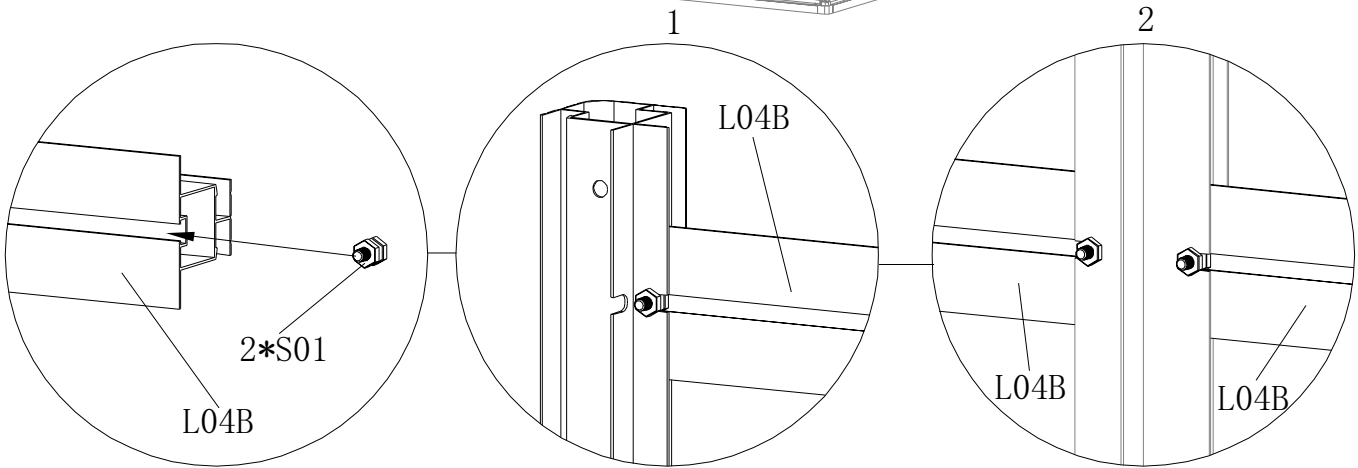

Note: please insert upper roof supports but, do not lock in place until you have aligned the poly-carbonate inserts.

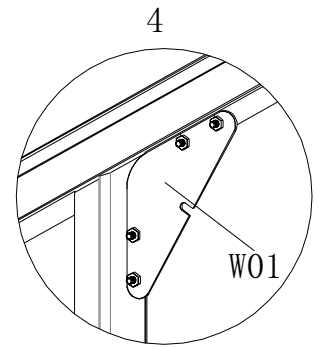
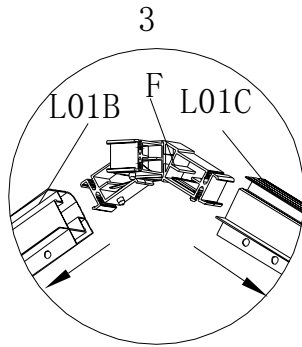
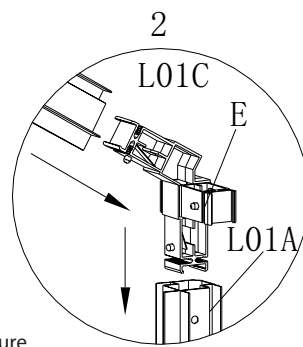
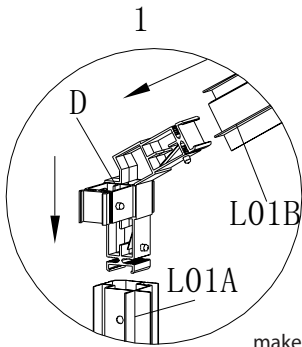
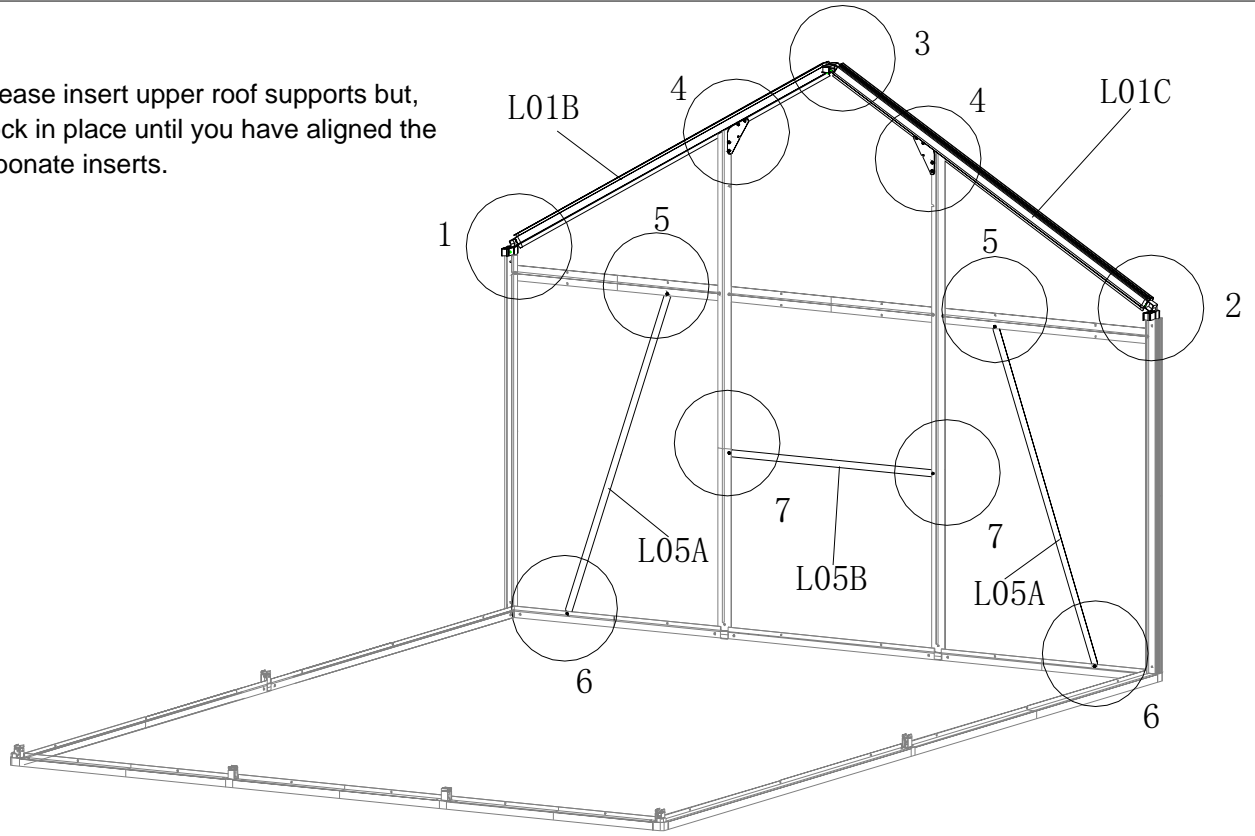

make sure you pay close attention to the direction of the pins

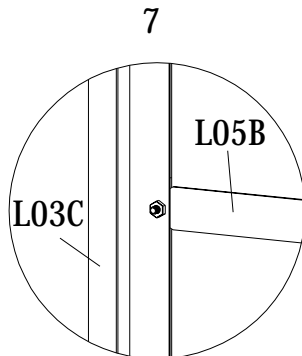
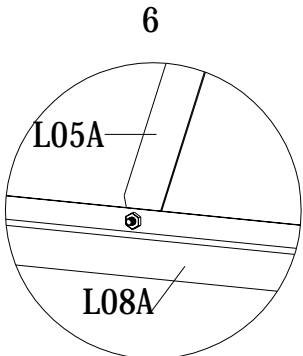
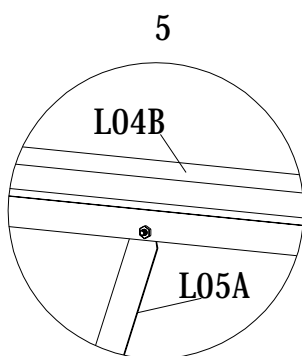

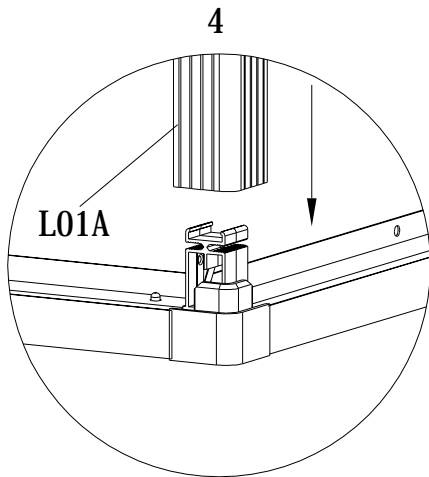
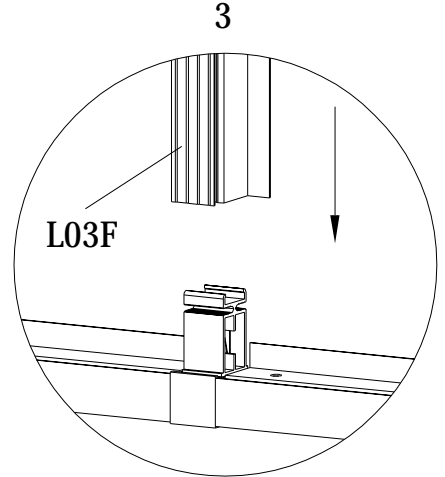
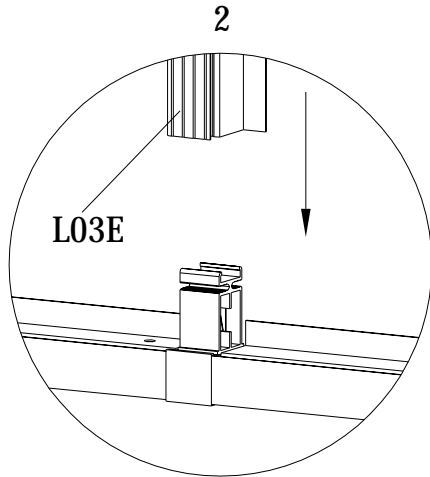
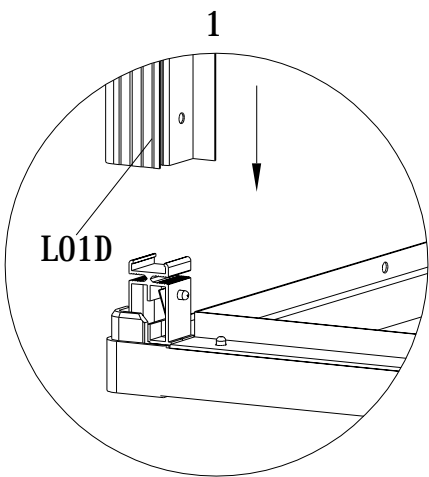
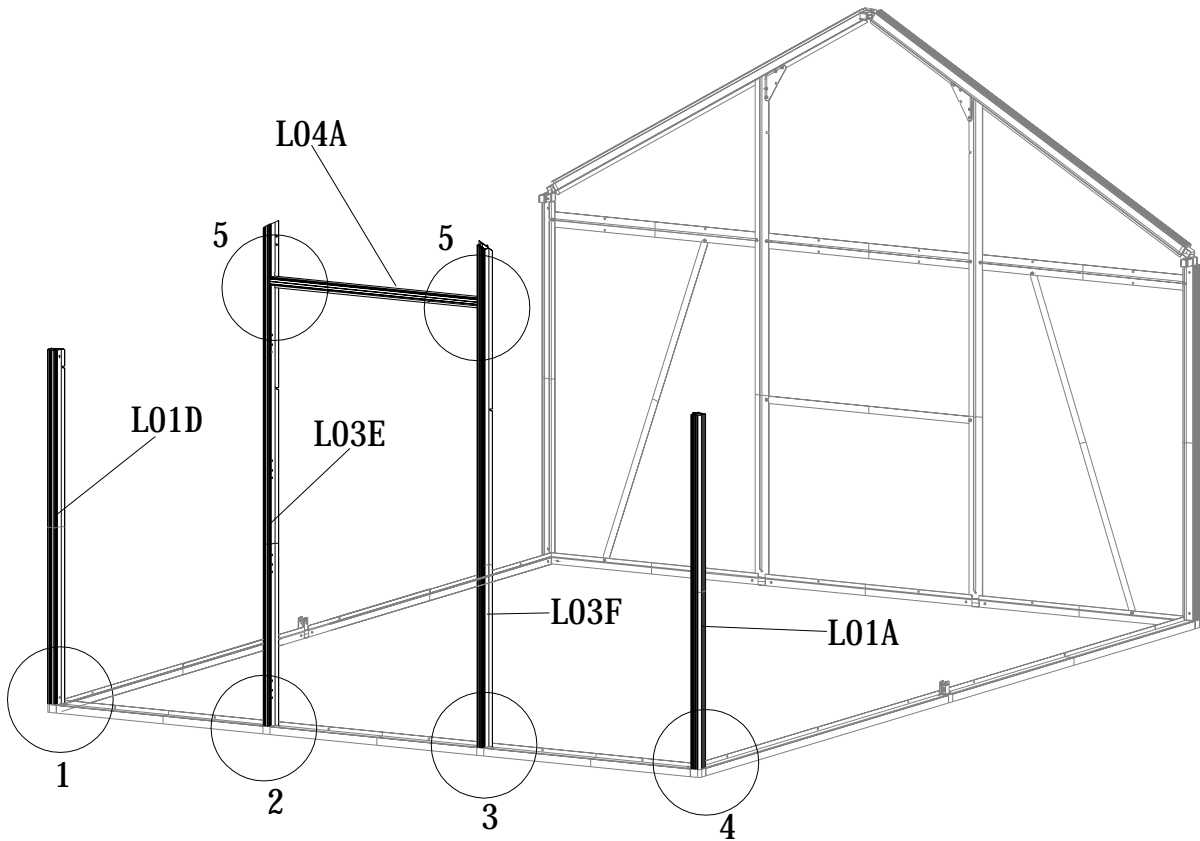

Slide 2*S01 into L04A, and tighten L04A at each end with S01

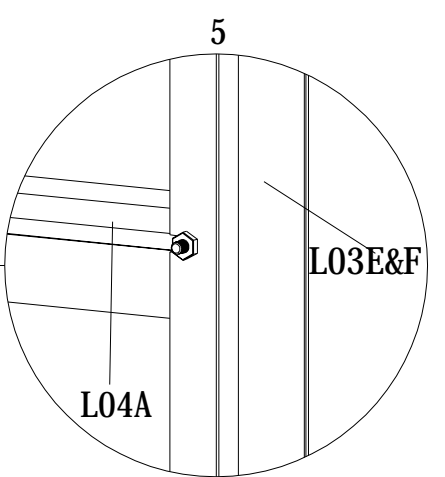
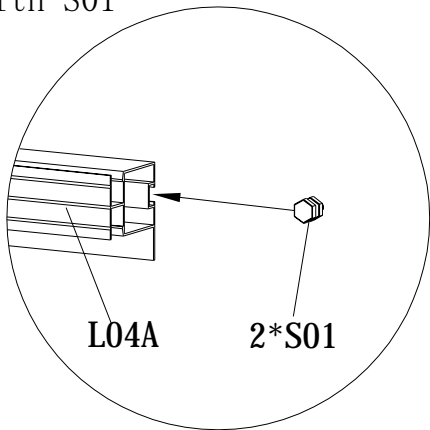

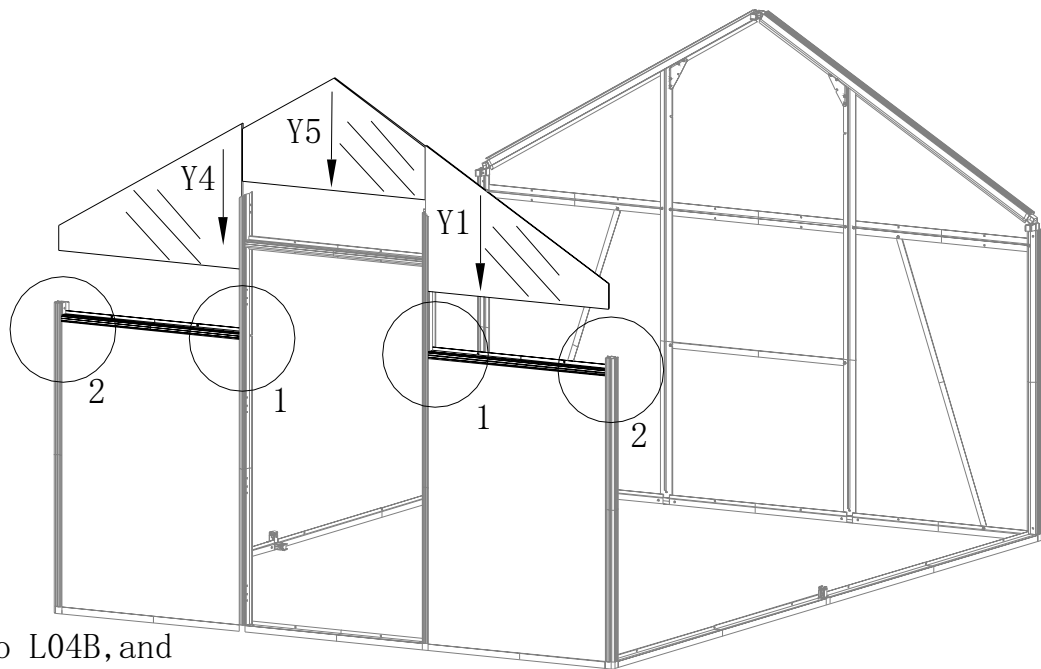
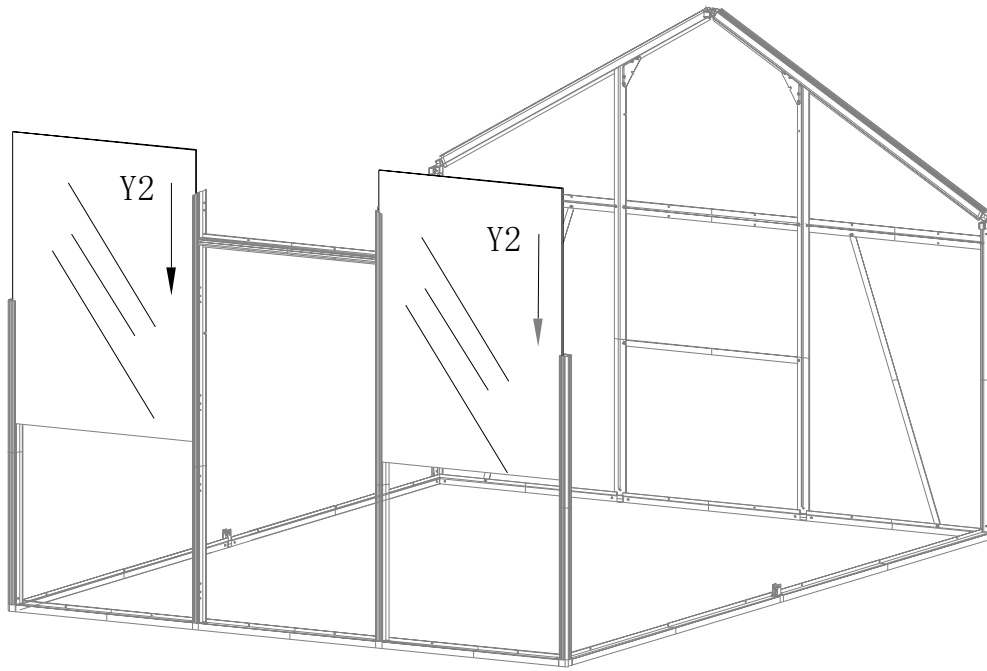

Slide 2*S01 into L04B, and
tighten L04B at each end
with S01

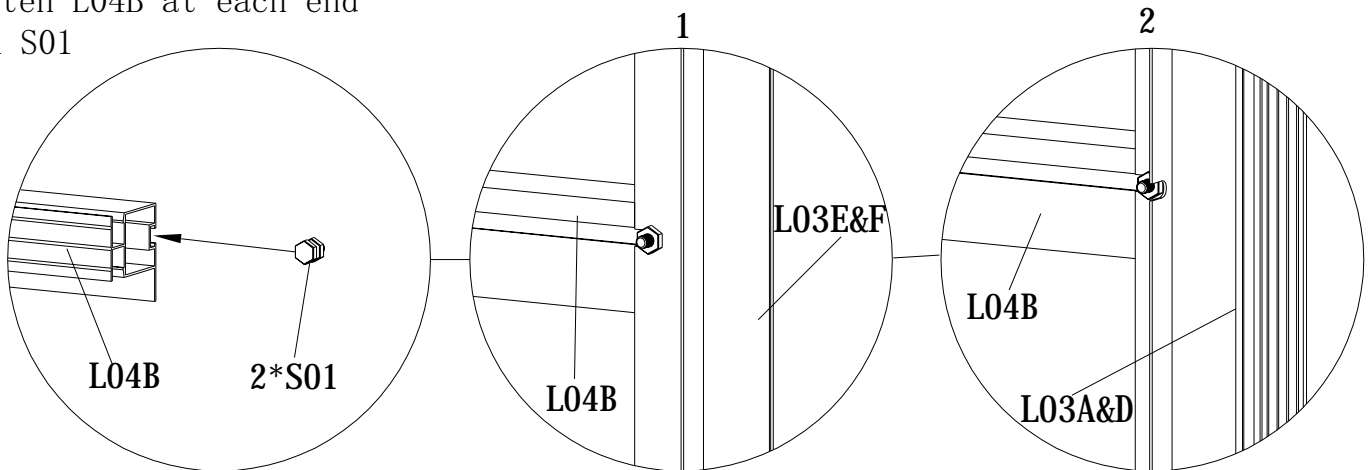

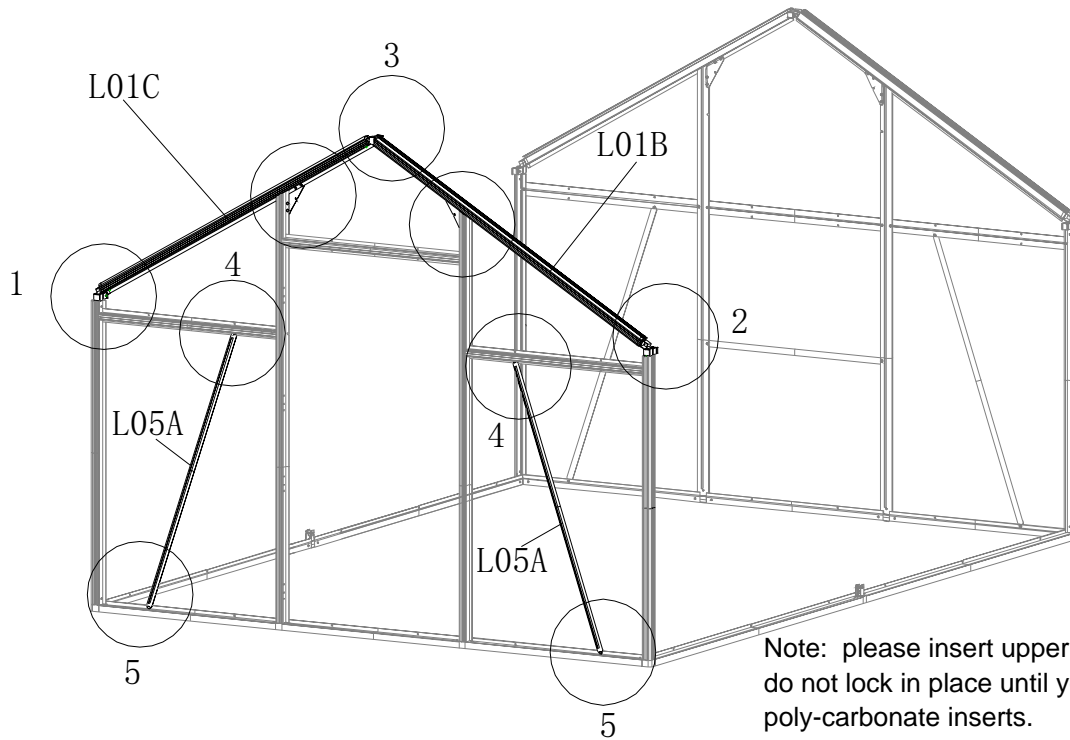

Note: please insert upper roof supports but, do not lock in place until you have aligned the poly-carbonate inserts.

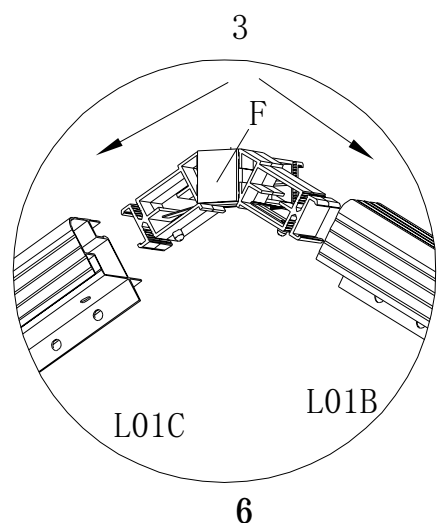
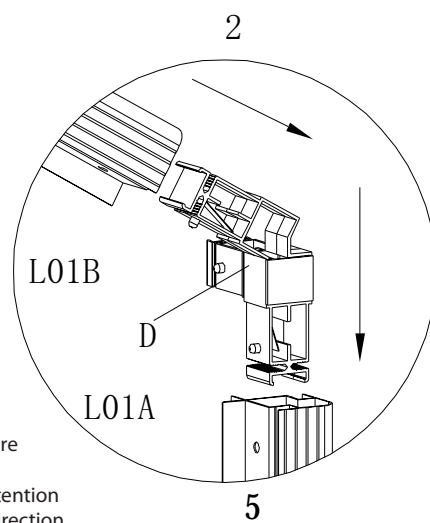
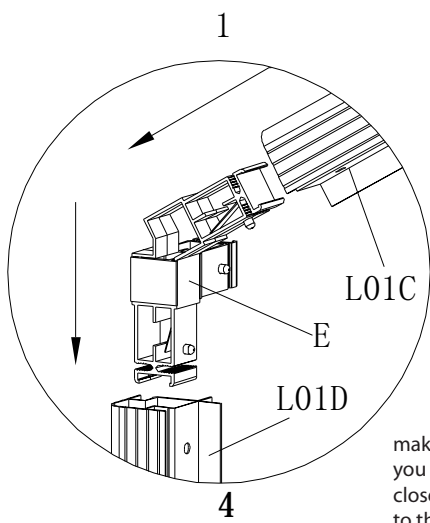

make sure you pay close attention to the direction of the pins

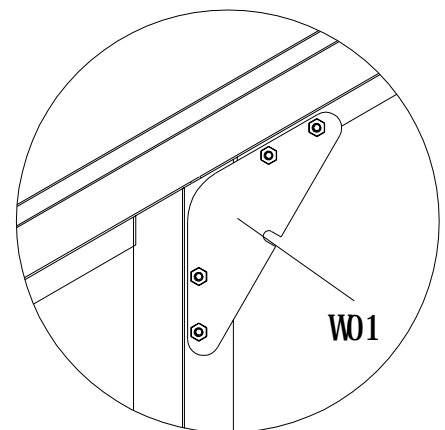
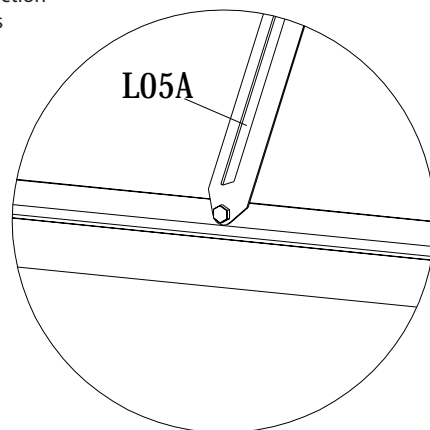
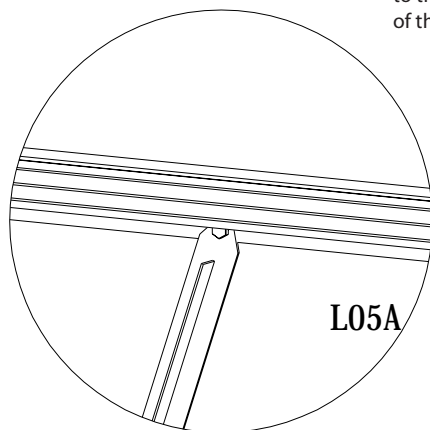

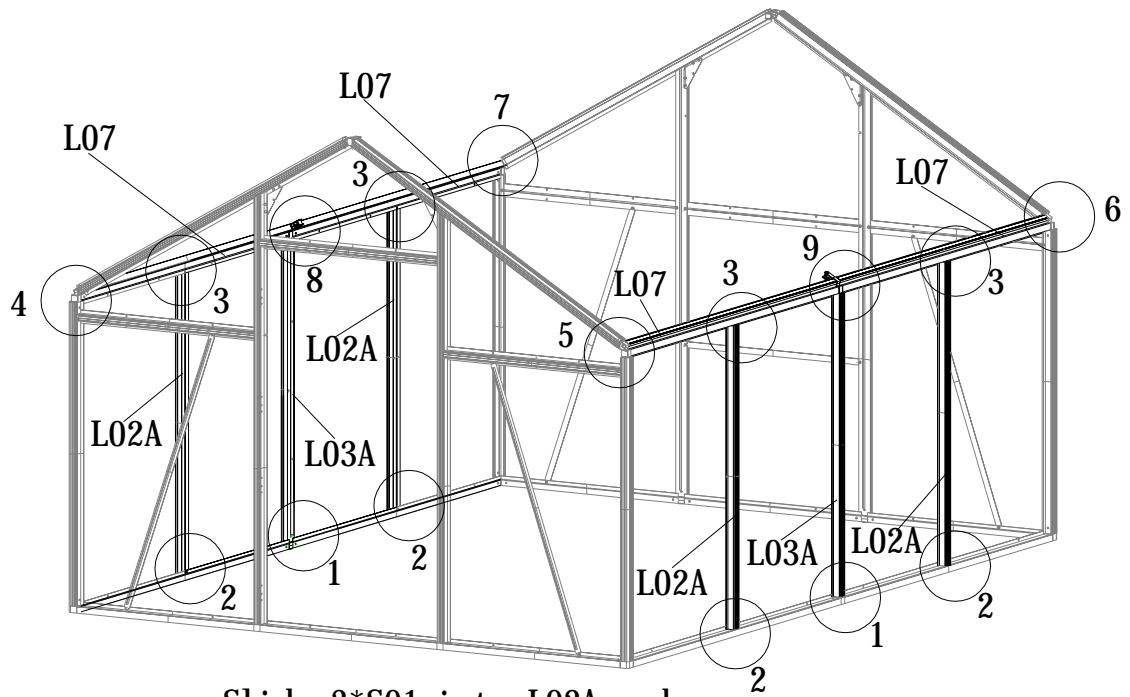

Slide 3*S01 into L02A, and
tighten L02A at each end
with S01

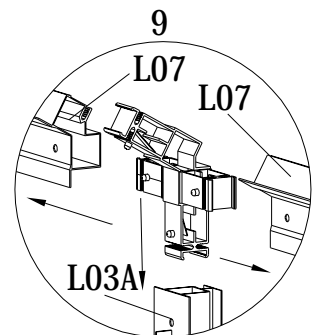
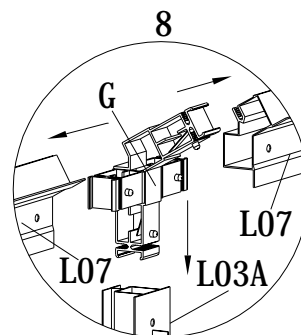
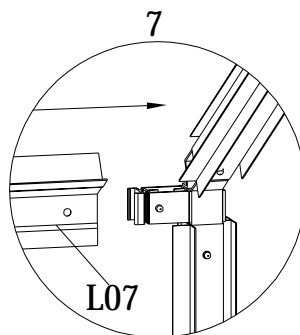
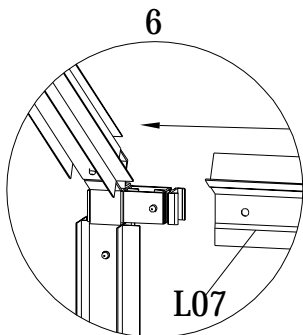
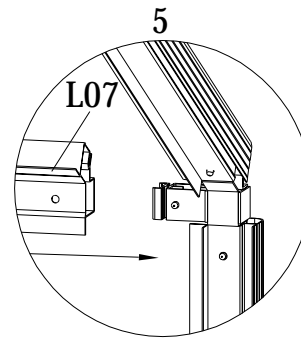
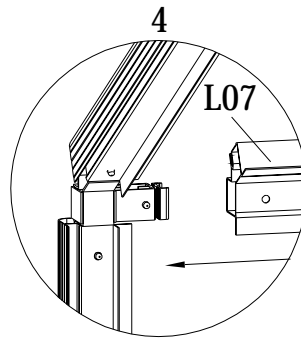
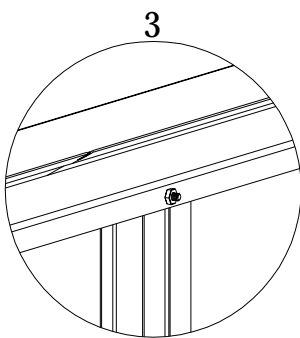
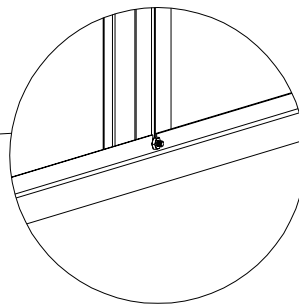
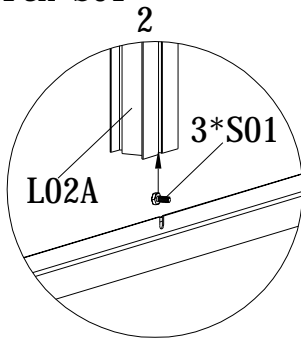
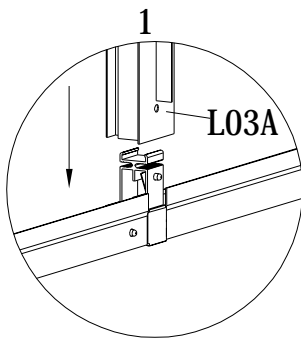

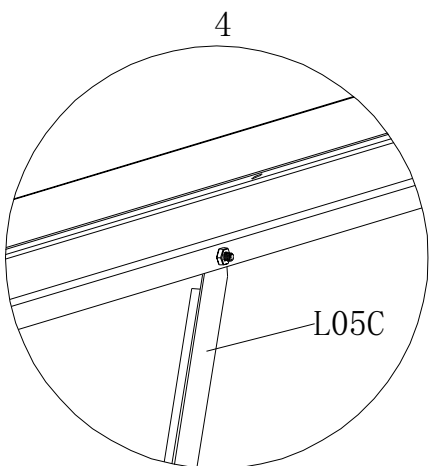
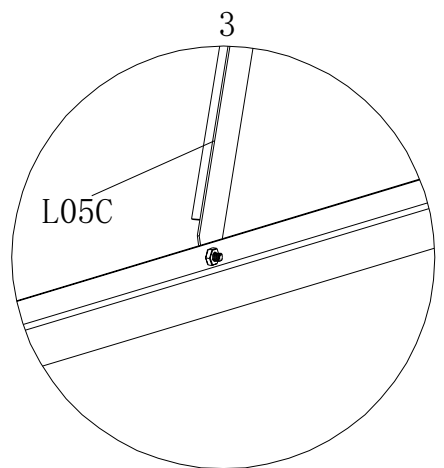
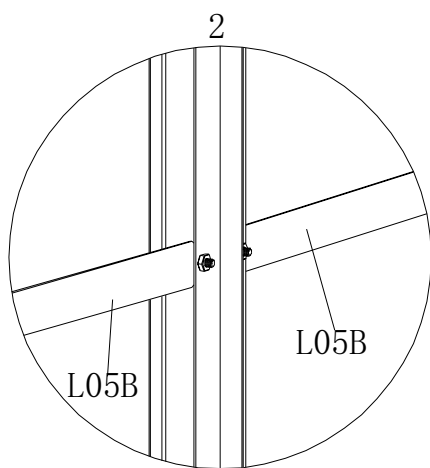
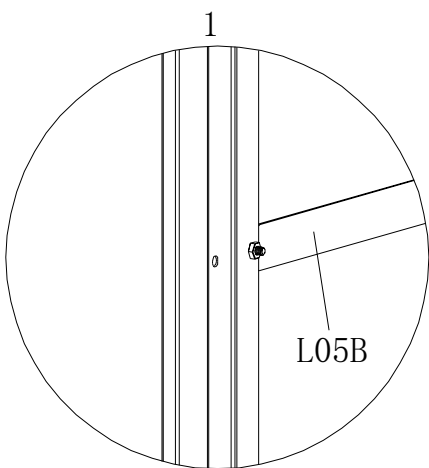
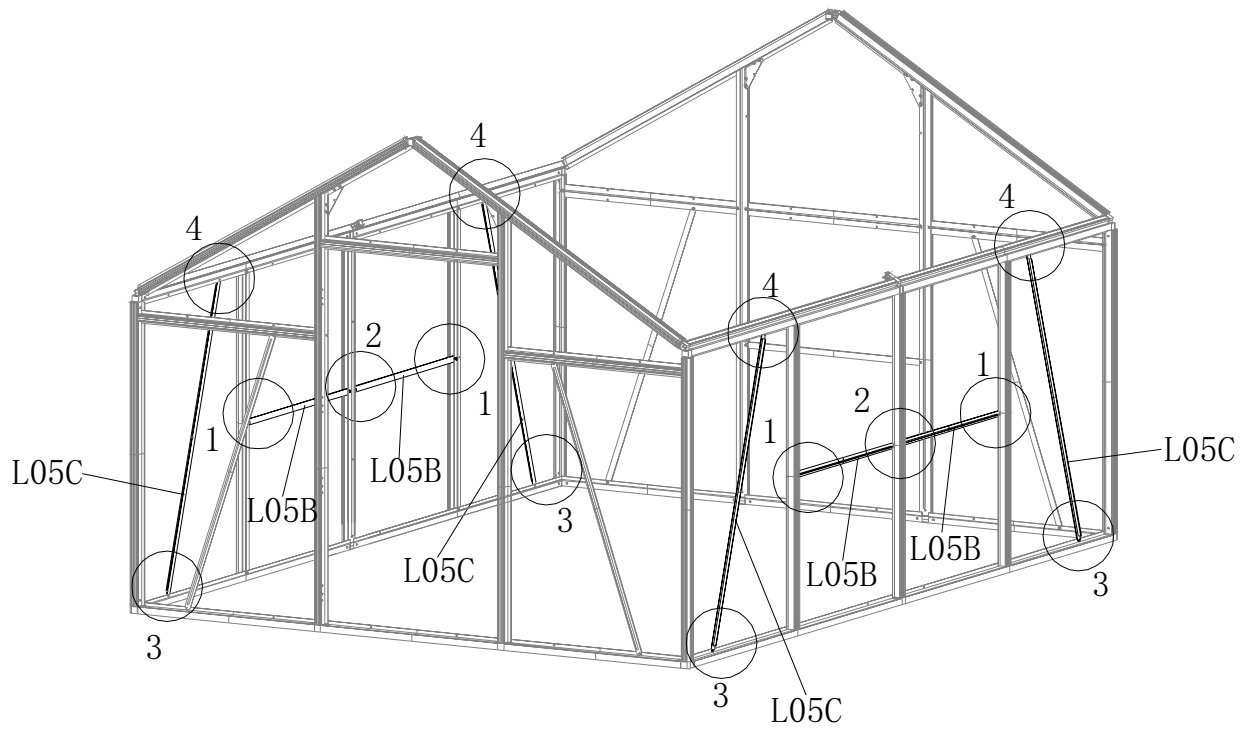

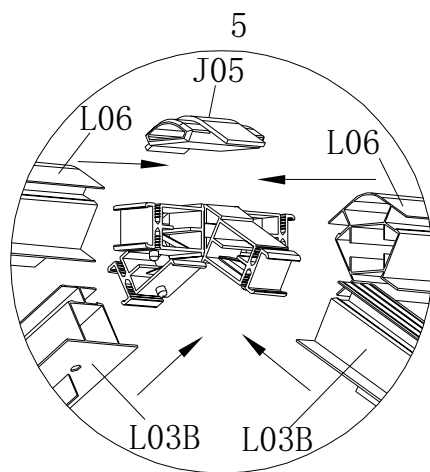
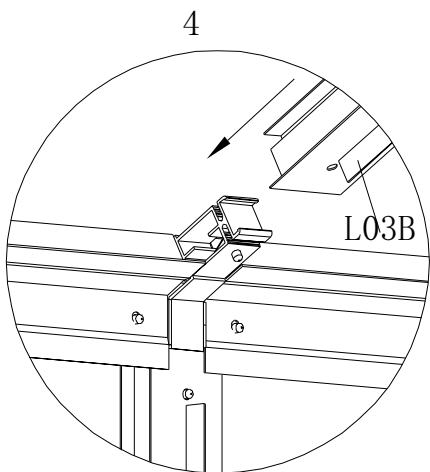
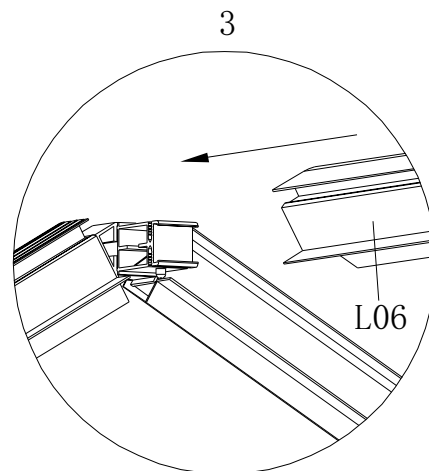
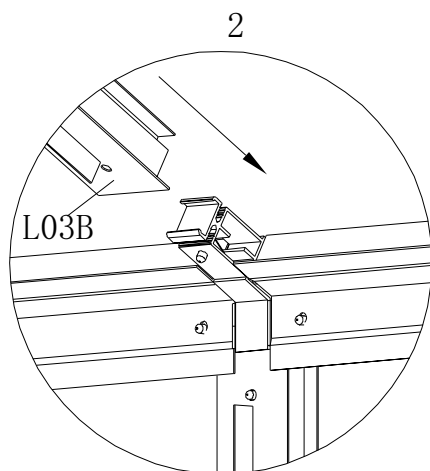
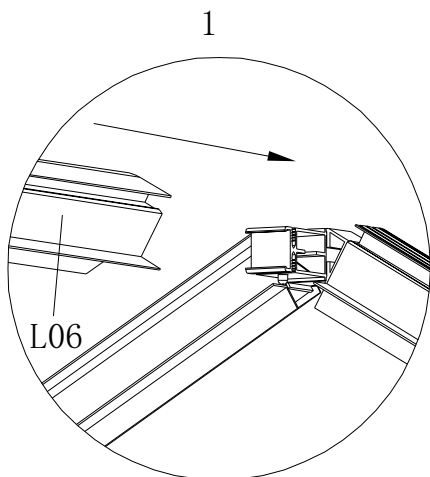
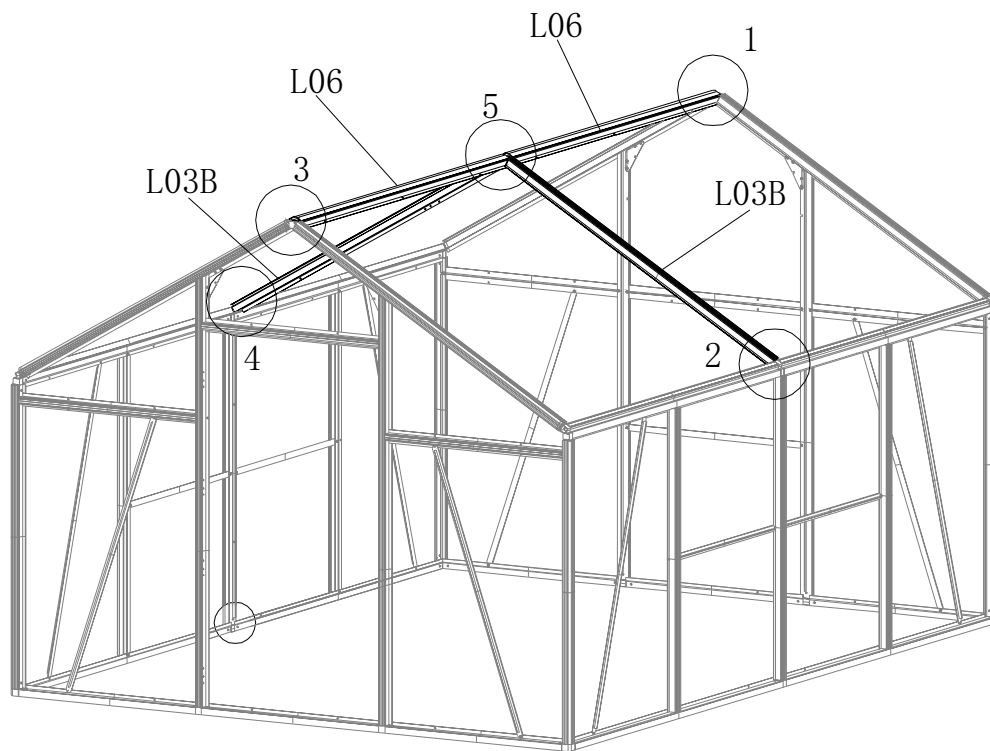

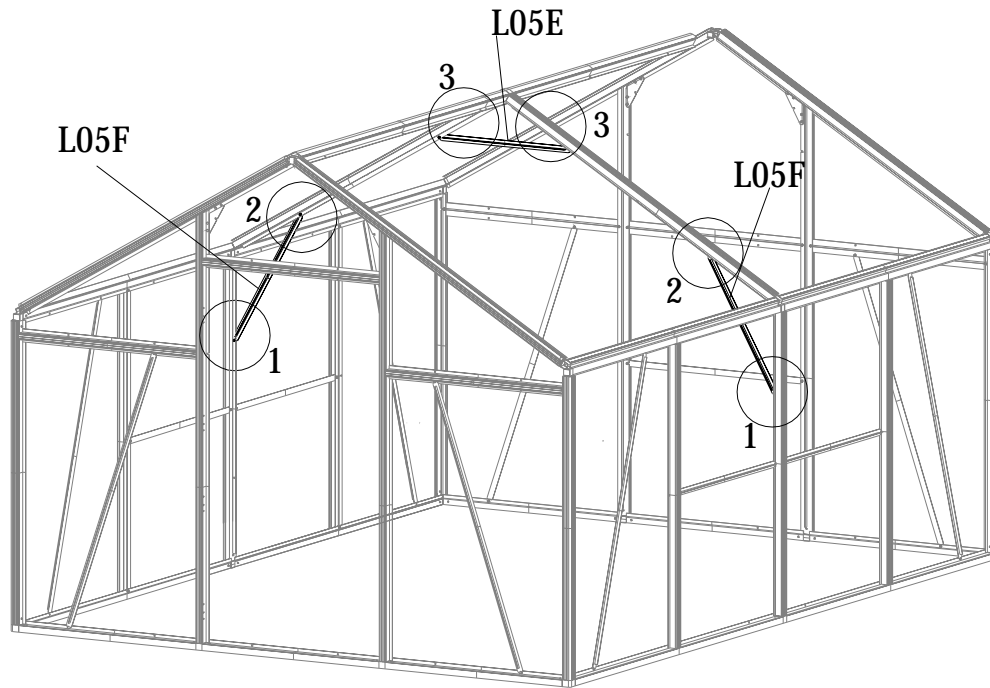

1

2

3

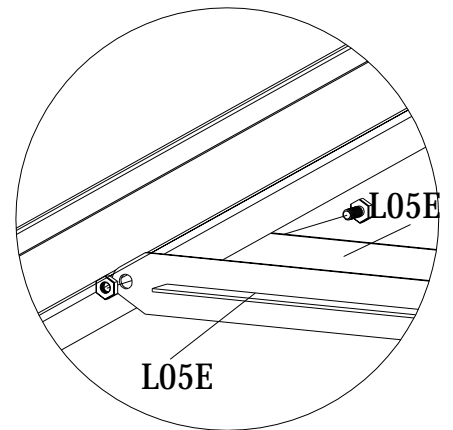
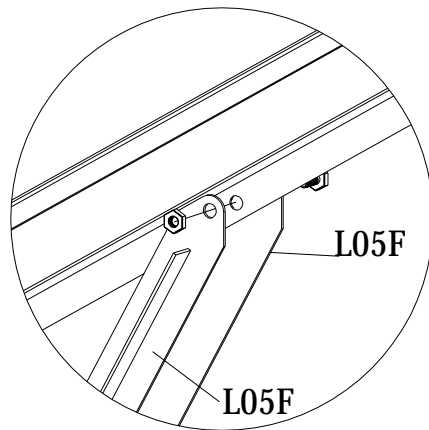
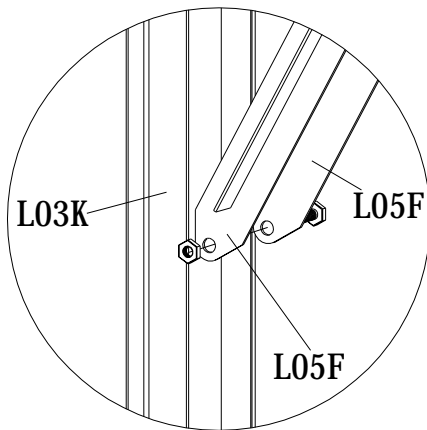

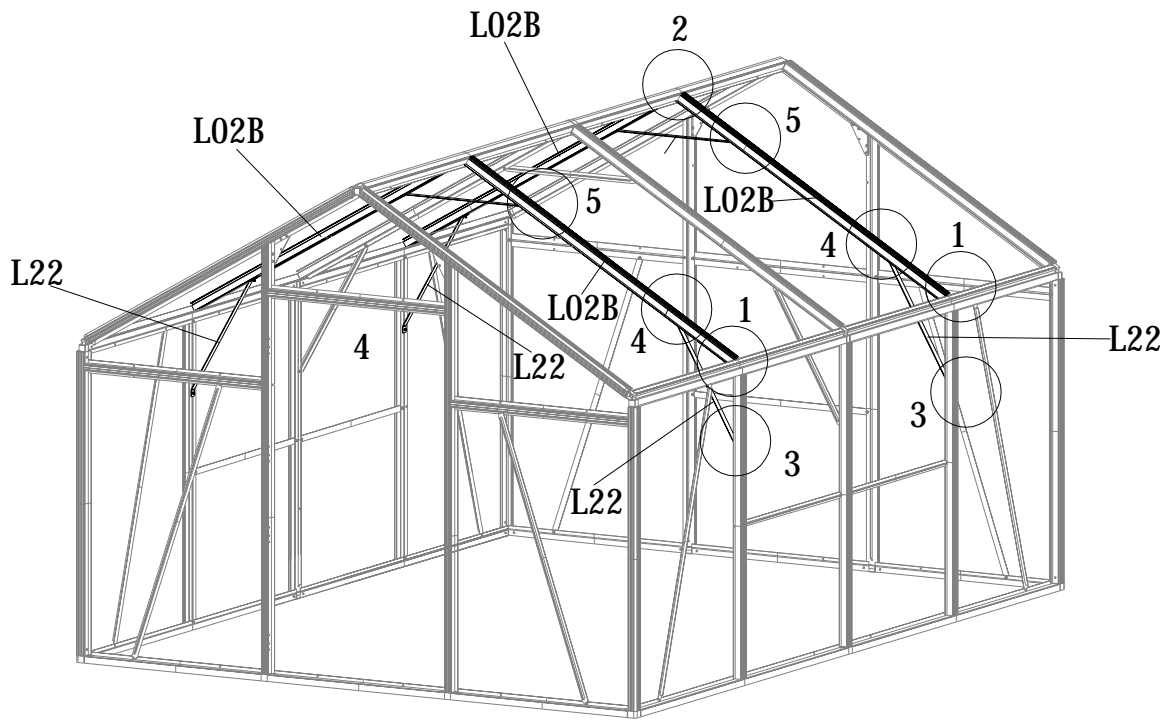

Note: Slide 4xS01 in the channel, which are needed later.

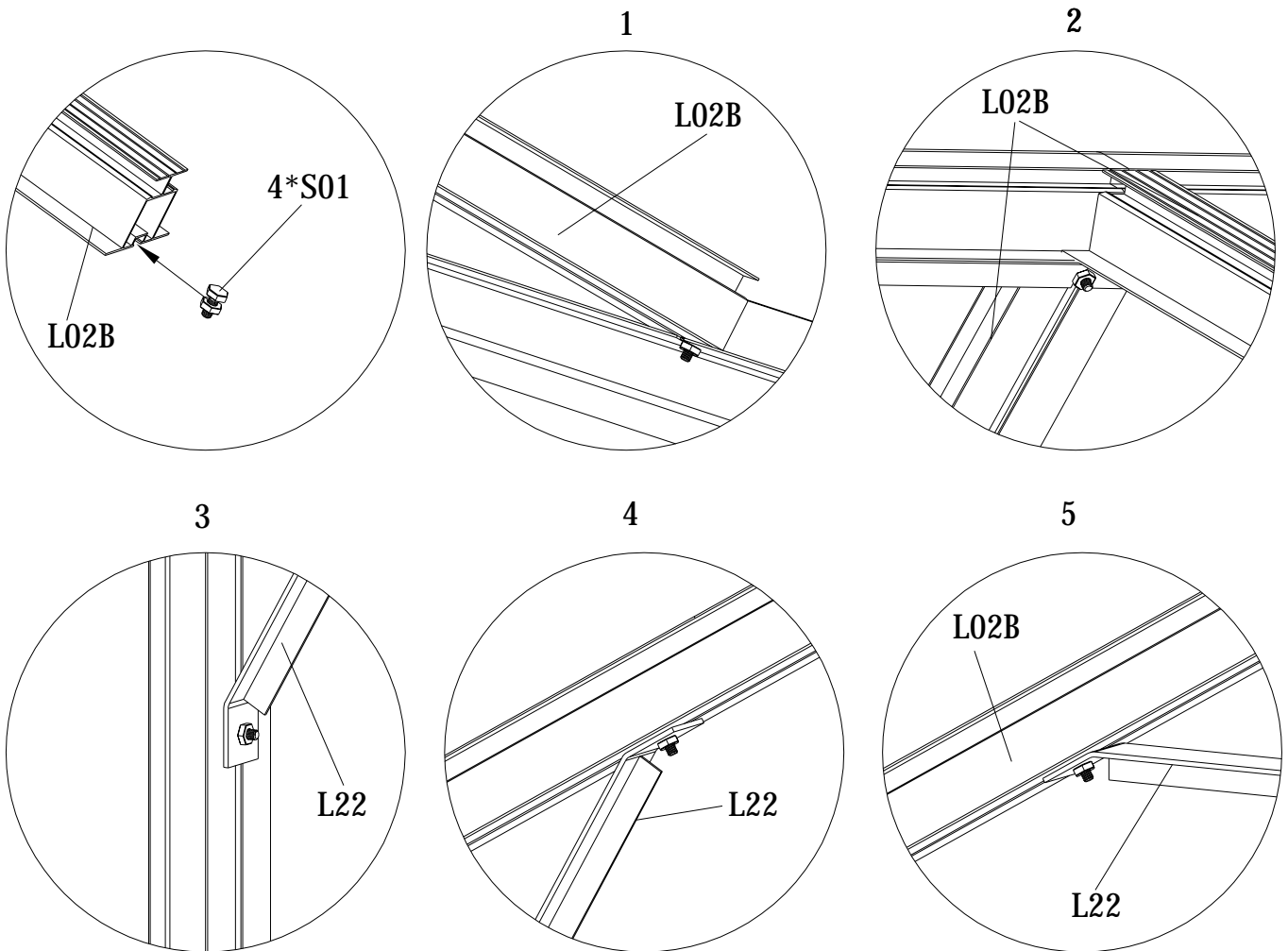

REPEAT the same assembly for the other side.

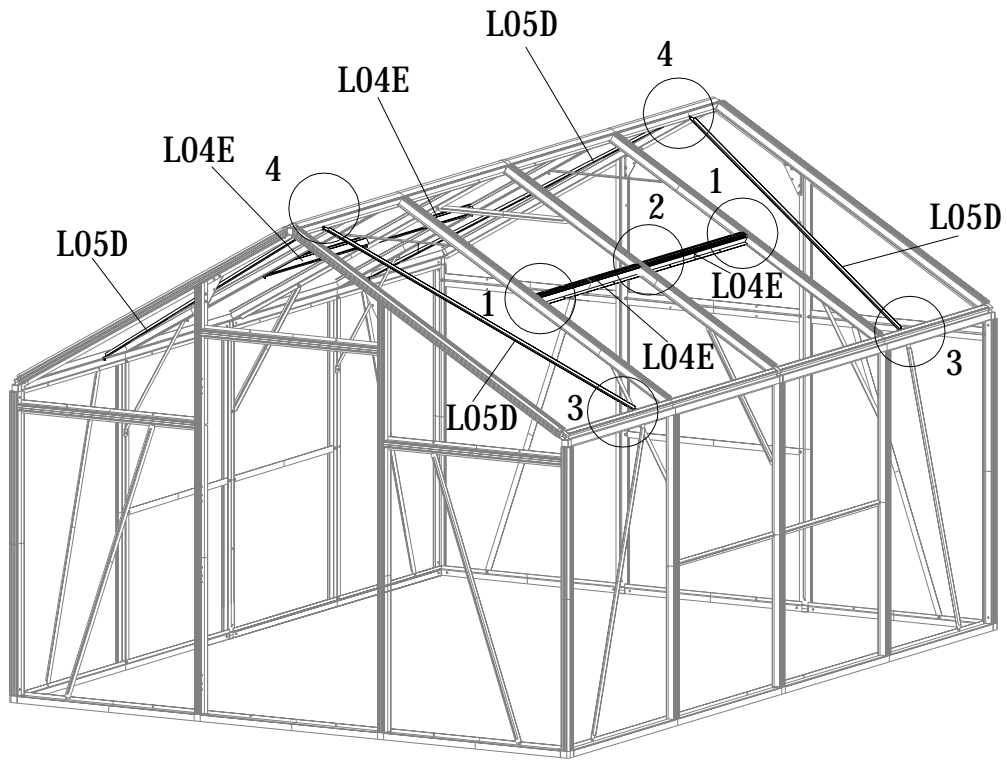

Pay attention to the cut edge of L04E which should be fixed, facing up.

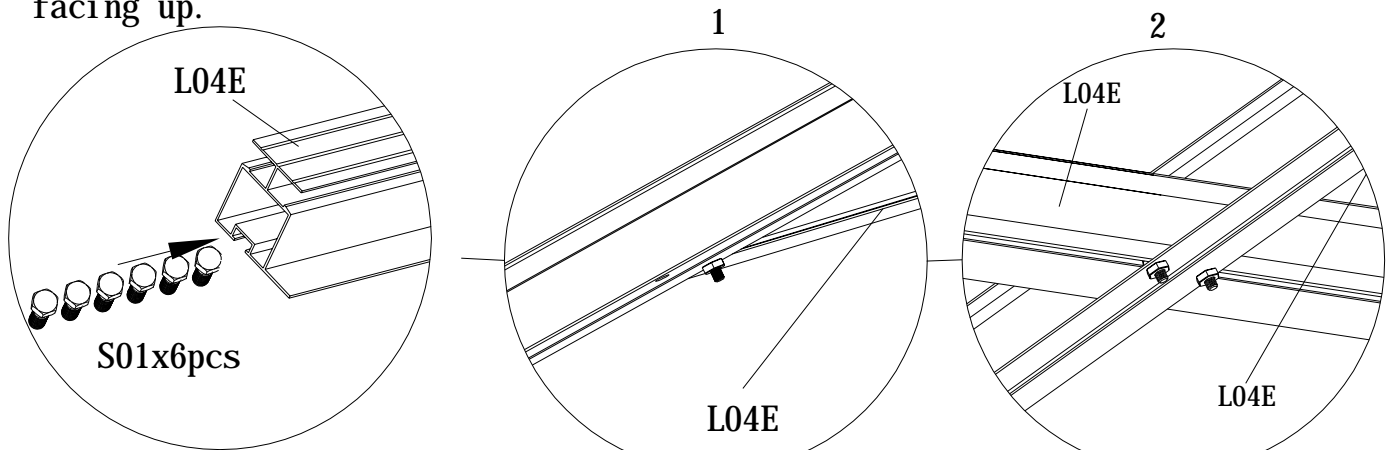

Note: Slide 6xS01 in the channel, which are needed later.

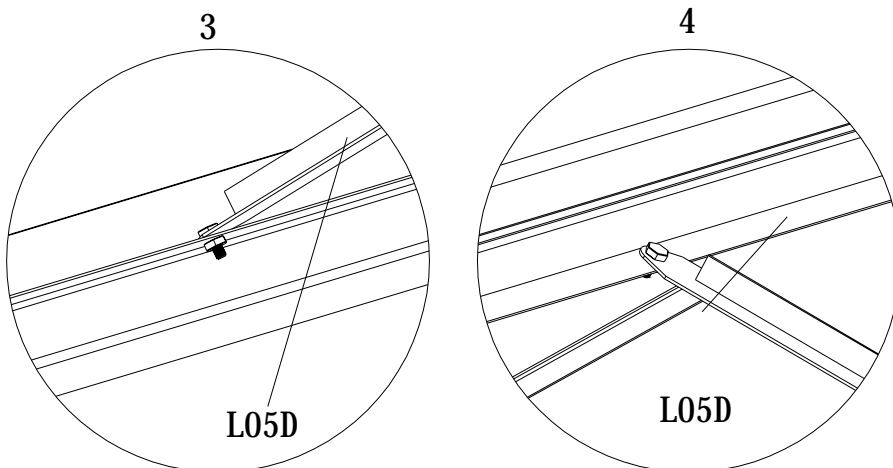

REPEAT the same assembly for the other side.

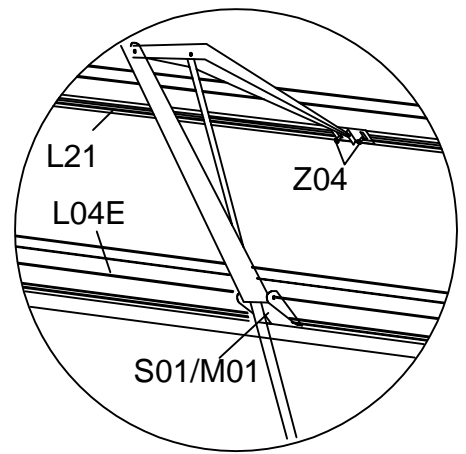
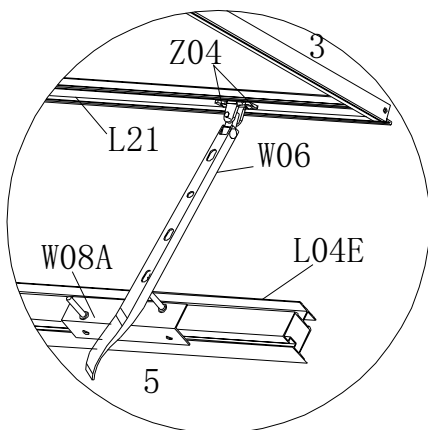
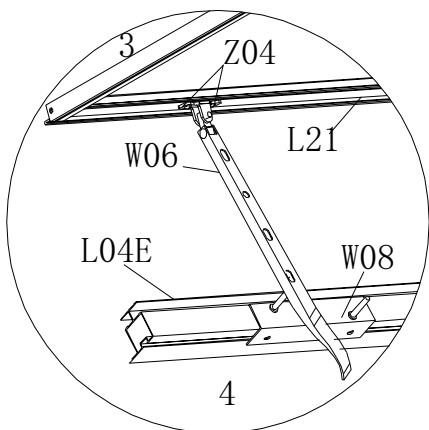
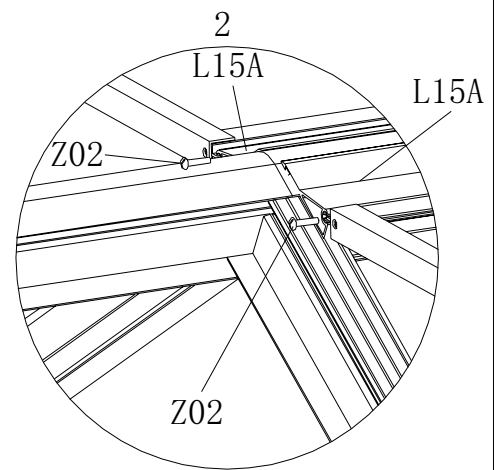
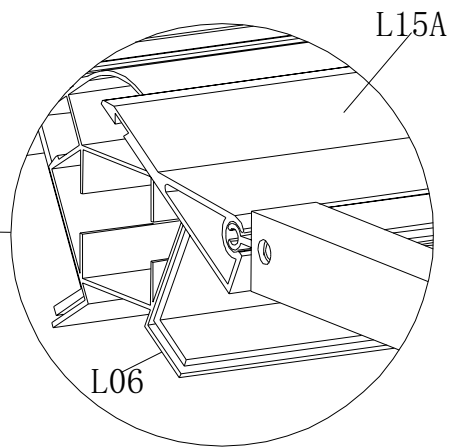
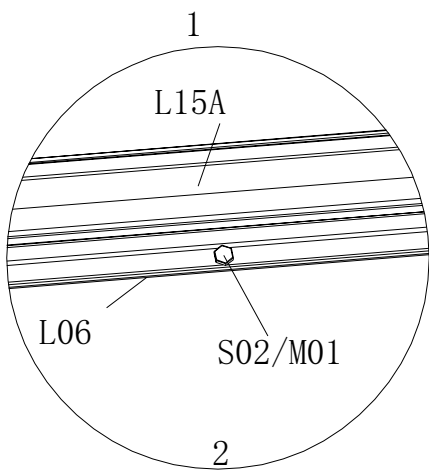
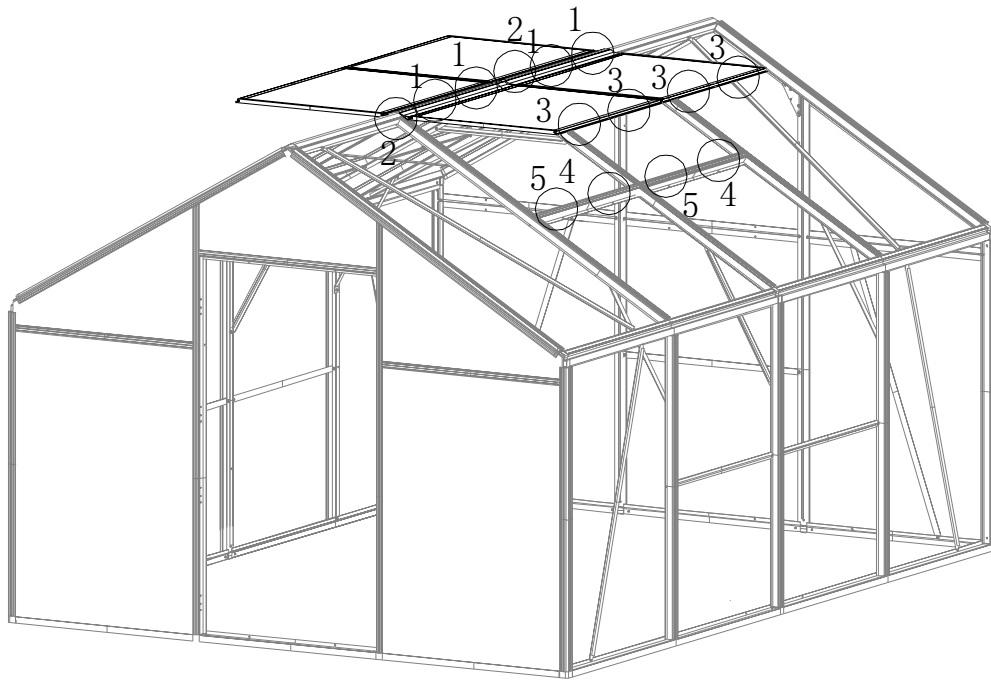

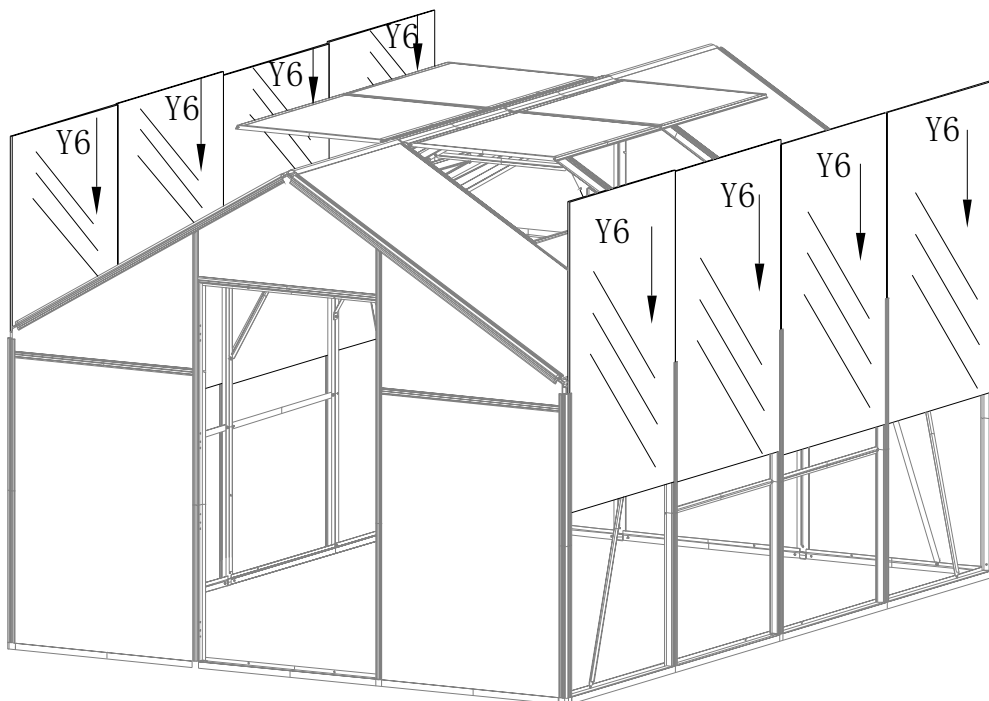
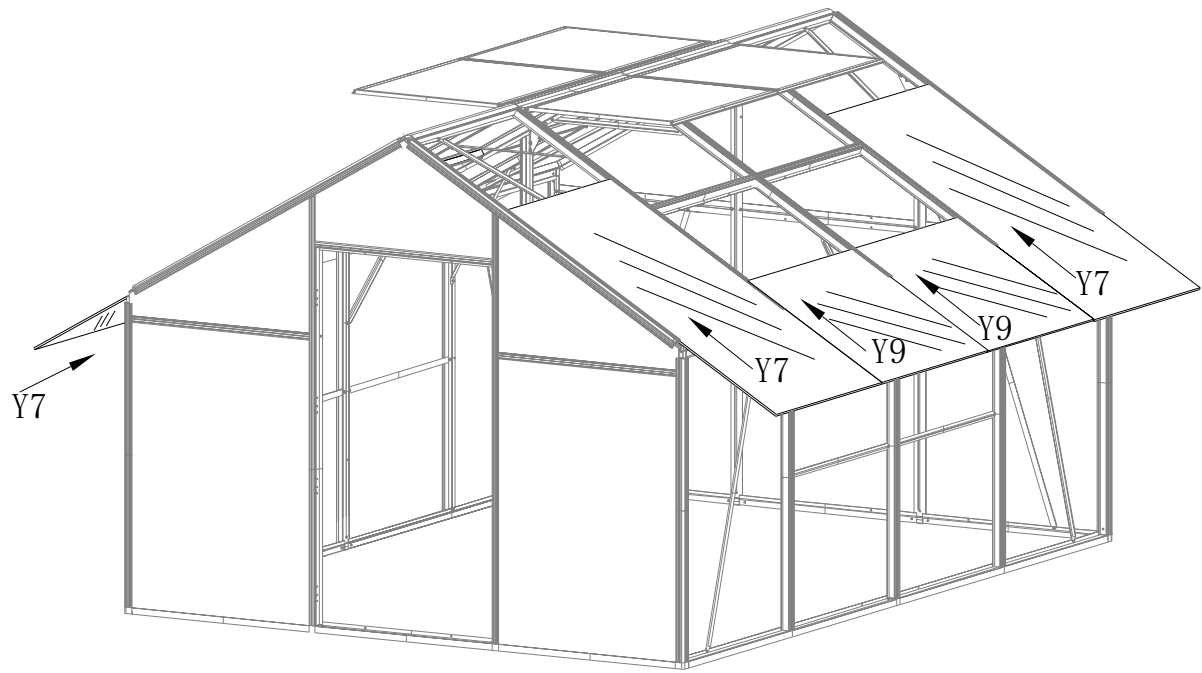

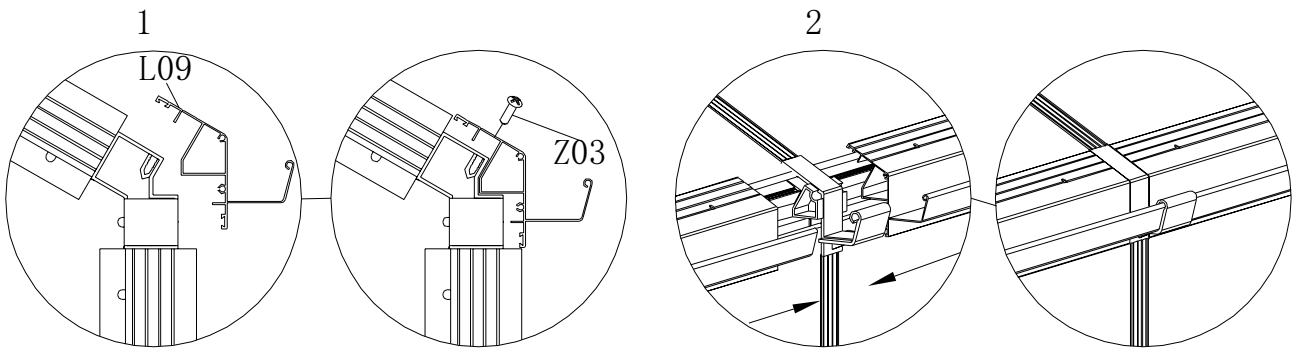
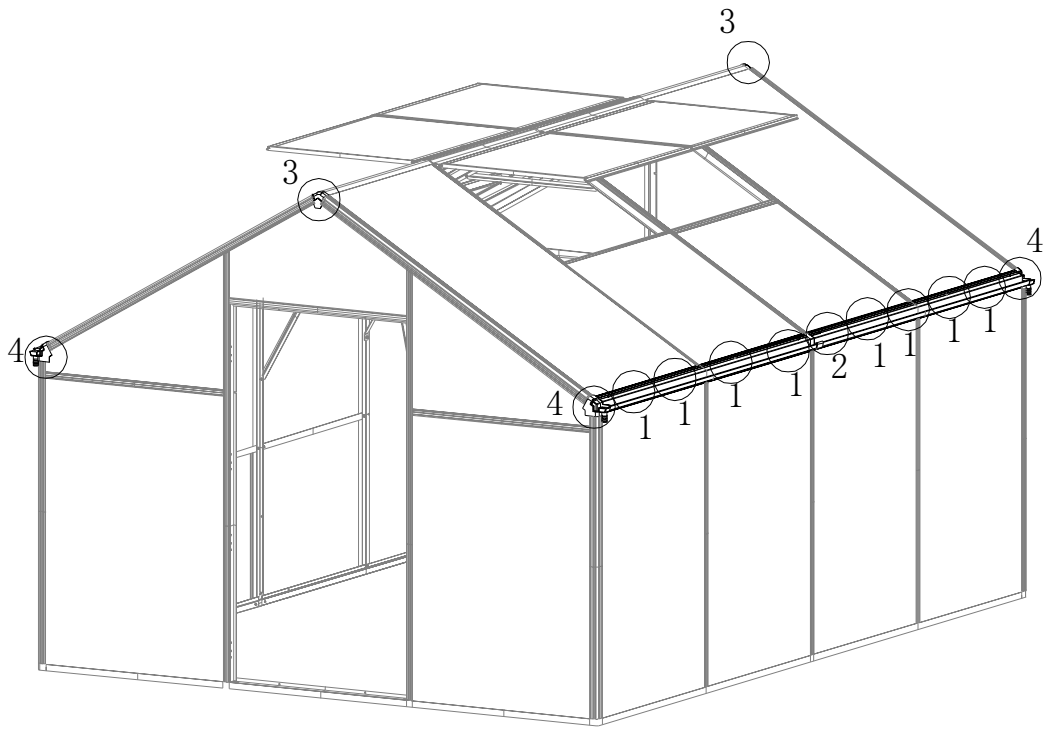

Use L09 to cover the edges of all Y9 after all roof PC panels are fixed in place, then tighten them with Z03.

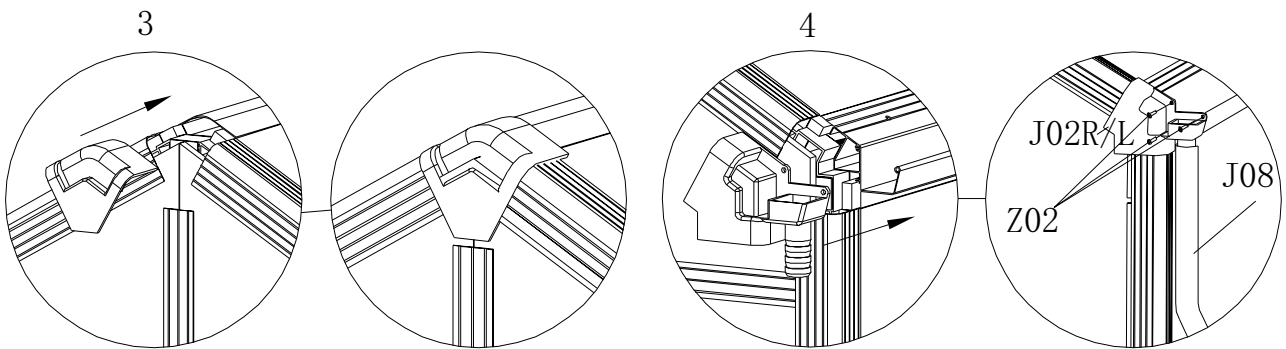

REPEAT the same assembly for the other side.

