

GROW MORE Greenhouses

Assembly Instructions

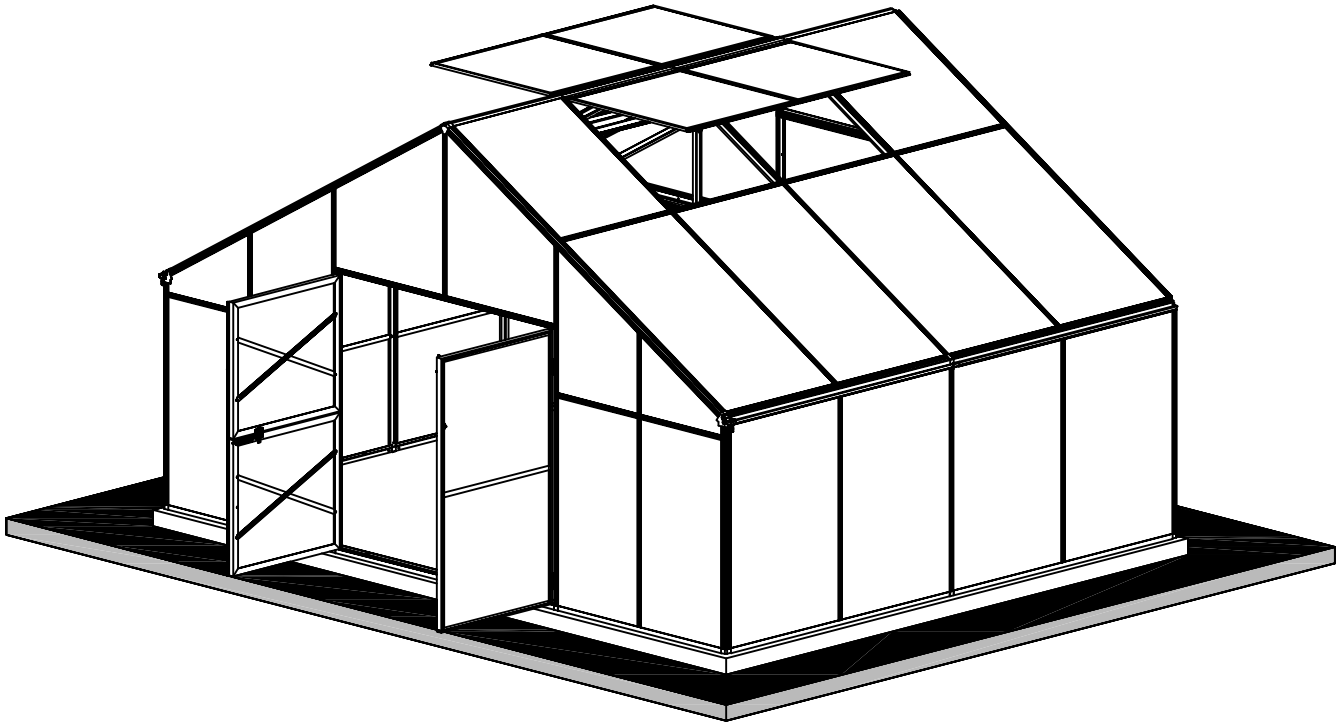

MODEL: GM16

GREENHOUSE SIZE: 13' 3 7/8"L x 16' 7 3/16"W x 9'11"H
406cm L x 506cm W x 302cm H

EXTENSION SIZE: 6'6 3/4"L x 16' 7 3/16"W x 9'11"H
200cm L x 506cm W x 302cm H

PLEASE READ INSTRUCTIONS CAREFULLY BEFORE ASSEMBLY

Item No.	Model No.	Packing List					
		AL No.1	AL No.2	AL No.3	AL No.4	PC No.1	PC No.2
2553300	GM16	1CTN <input type="checkbox"/>	1CTN <input type="checkbox"/>	1CTN <input type="checkbox"/>	1CTN <input type="checkbox"/>	1CTN <input type="checkbox"/>	2CTNS <input type="checkbox"/>
2553350	GM16 ext				1CTN <input type="checkbox"/>		1CTN <input type="checkbox"/>

ACF Greenhouses.com

Customer Support

Support@ACFgreenhouses.com

1-888-888-9050

CONTENTS

1. Assembly Advice	Page 1
2. Product Features	Page 1 - 2
3. Parts List	Page 3 - 6
4. Base Assembly	Page 7 - 10
5. Door Assembly	Page 11 - 13
6. Roof Vent Assembly	Page 14
7. Framework & Panel Assembly	Page 15-38

Assembly and Maintenance Advice

1. For safety purposes, we strongly recommend that this product is assembled by at least two people.
2. Some components have sharp metal edges. Please be careful when handling metal components. Please wear gloves, shoes and safety goggles during assembly.
3. Lay all of the components on a soft carpet or blanket to avoid any scratches or damages.
4. DO NOT climb or stand on the roof. Heavy articles should not be leaned against the greenhouse.
5. Keep the roof and gutter clear of snow, dirt & leaves. Allowing snow to build up on the roof may damage the product.
6. Unlike steel, if the paint finish is scratched this will not harm the aluminium underneath.
7. When your product needs cleaning, use a mild detergent solution and rinse with cold clean water. Do not use acetone, abrasive cleaners or strong detergents to clean the panels.

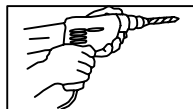
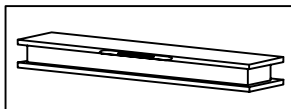
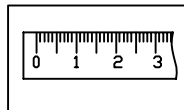
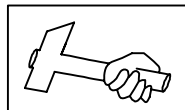
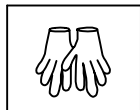
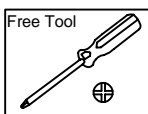
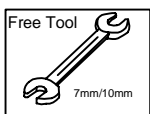

Functions and Features:

1. Compared with traditional greenhouses this exciting product features many significant improvements. The hollow box profile aluminium framing is much stronger than other greenhouses and it can withstand much greater pressure.

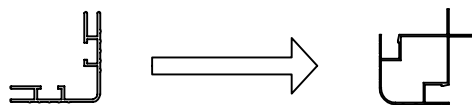

2. Easy and fast assembly.

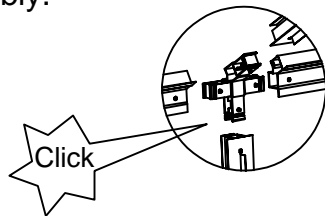

3. The strong two part eaves beam includes an integral gutter. Downpipes are also included as standard so you can collect rainwater.

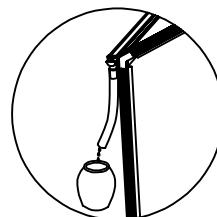

5. A steel base is not required as the aluminium base frame is fixed to the necessary concrete footings with the expansion bolts provided, alternatively you can easily secure it to a timber base with timber screws(not provided).

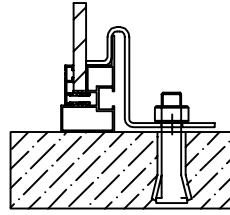

Expansion screw / Concrete ground

6. The Grange Series greenhouses come standard with Manual opening arms. Automatic openers can be purchased seperately and fitted to any window vent. We recommend two automatic vent openers be fitted to each vent in the same positions the standard manual vent arms.

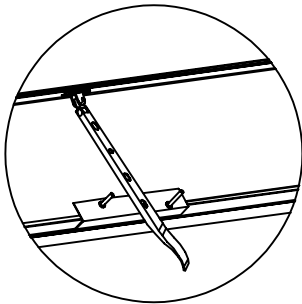

Manual opener

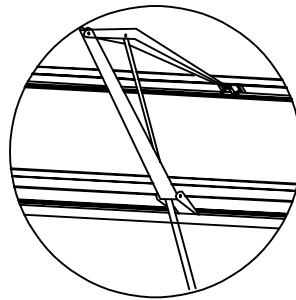

Automatic opener



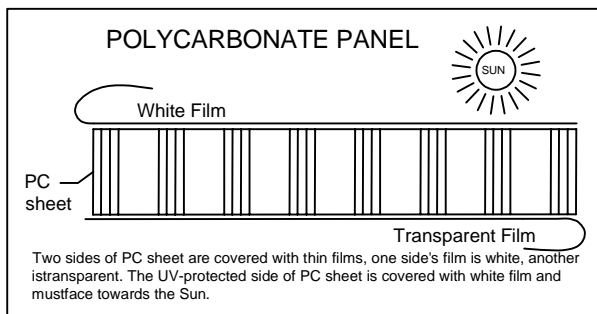

7. Please ensure the roof vents are not installed into the end roof bays of the greenhouse as this is where you need the bracing.
8. Each Polycarbonate Panel comes with UV protected properties. Please ensure the clear film with the text faces out, toward the sun Remove both films before installation of the panels.

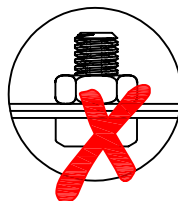
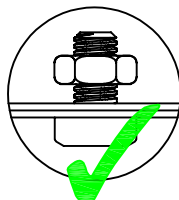









9. Nuts not to be tightened before the end of assembly! Unless otherwise stated, do not tighten the bolts/nuts/screws until the shed is finally erected!









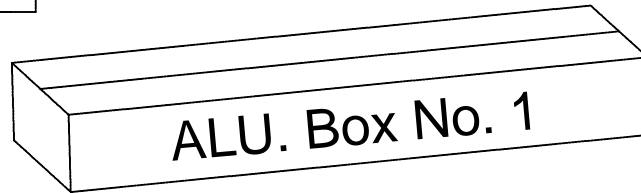



ALU. Box No.1











	PART	NO.	QTY.
1		L01A	4
2		L02C	2
3		L02D	2
4		L02F	3
5		L02G	4
6		L03C	1
		L03D	1
7		L03E	1
		L03F	1

	PART	NO.	QTY.
8		L04A	1
		L04C	1
9		L04D	8
10		L04E	2
11		L05A	4
		L05B	2
12		L08A	4
13		L08B	2









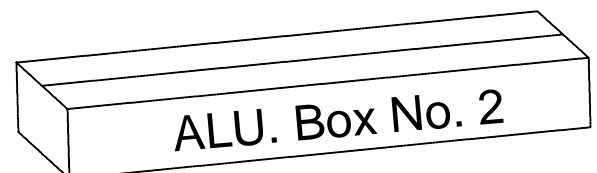





ALU. Box No.2









	PART	NO.	QTY.
1		L01B	2
		L01C	2
2		L02A	2
3		L02B	2
4		L02E	1
		L02F	2
5		L04B	2
6		L05B	2
		L05C	2
		L05D	2





















	PART	NO.	QTY.
7		L06	1
8		L07	2
9		L08B	2
10		L09	2
11		L15A	2
12		L19	4
		L20	2
		L21	2
13		L04E	2
14		L22	3



ALU. Box No.3







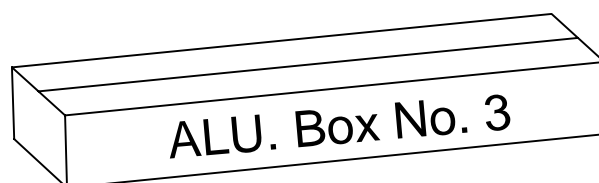











	PART	NO.	QTY.
1		L18A	2
2		L18B	2
3		L18C	1
		L16A	1
		L16B	1
		L16C	1
4		L18D	1
		L18F	1
5		L18E	2
6		L17	1
		L05G	4
		L05H	4
7		L30	4







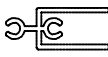

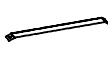











PART	NO.	QTY.
	S05	175
	M6X12	
	S11	4
	M6X20	
	M03	179
	M6	
	Z09	26
	Ø5X15	
	Z02	24
	Ø4X16D	
	Z10	8
	Ø5X30	
	Z04	12
	Ø4X8	
	Z06	4
	Ø3.2X10	
	S08	14
	M8X60	

PART	NO.	QTY.
	A52	2
	A53	2
	A54	4
	A09	2
	A10	2
	A11	2
	A14	12
	D17	10
	D04	1
	A01	4
	A69	2
	A70	2
	D07	14
	H10	2
	J01R/L	2/2
	J03	4
	J02	2
	J06R/L	2/2
	J92	4
	J93	4















ALU. Box No.4 (2 Section Assembly)

	PART	NO.	QTY.
1		L02A	2
2		L02B	2
3		L02F	2
4		L02H	2
5		L02K	1
6		L03A	2
7		L03B	2
8		L04B	2
9		L05B	2
		L05C	2
		L05D	2
10		L06	1
11		L07	2
12		L08B	2
13		L09	2
14		L15A	2
15		L19	4
		L20	2
		L21	2
16		L04E	2
17		L22	3

PART	NO.	QTY.
	A12	2
	A13	1
	A54	2
	D18	2
	D19	2
	D20	2
	A01	4
	A69	2
	A70	2
	J03	2
	J04	1
	J07	2
	S05	86
	M5X25	
	S11	4
	M6X20	
	M03	90
	M6	
	Z02	12
	Ø4X16D	
	Z10	8
	Ø5X30	
	Z04	8
	Ø4X8	
	S08	4
	M8X60	
	D07	4





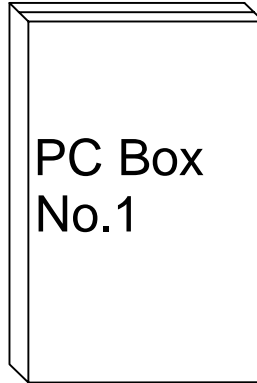

PC Box No.1

PART	NO.	QTY.
	Y1	2
	Y2	2
	Y3	1
	Y4	2
	Y5	1
	Y8	1
	Y11	2
	Y12	2
	Y13	1
	Y14	8
	Y15	2
	Y16	2



PC Box No.2 x 2PCS (2 Section Assembly)

PART	NO.	QTY.
	Y6	4
	Y7	2
	Y9	4
	Y10	2

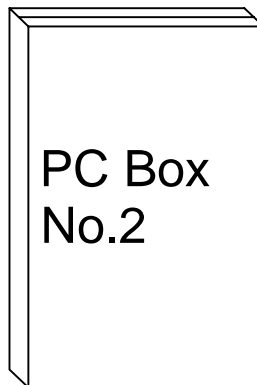

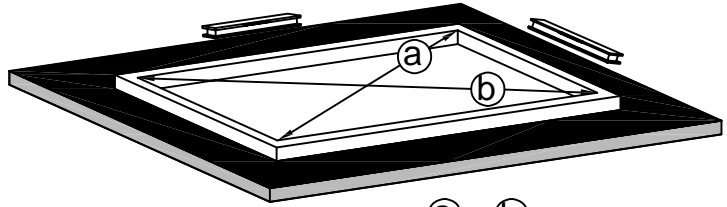
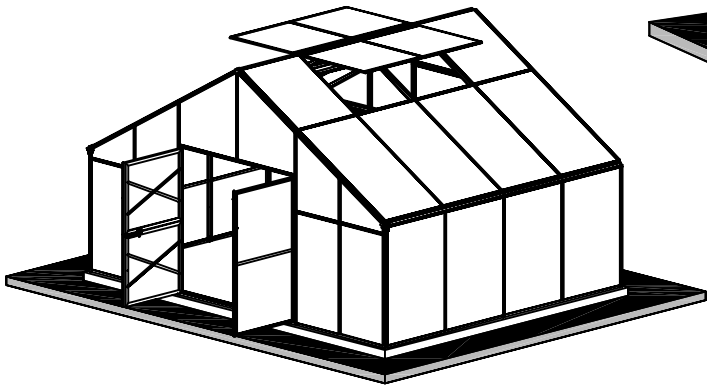

a = b

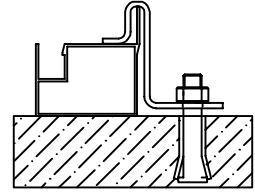
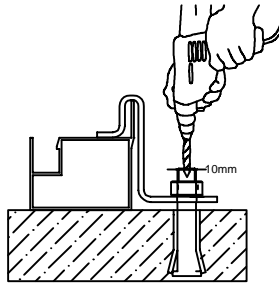

Expansion bolt
in concrete

It is essential the dimensions a + b are the same to ensure the base is square.

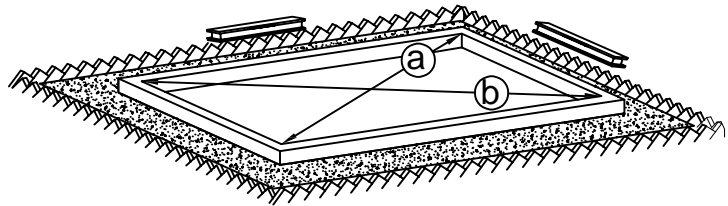
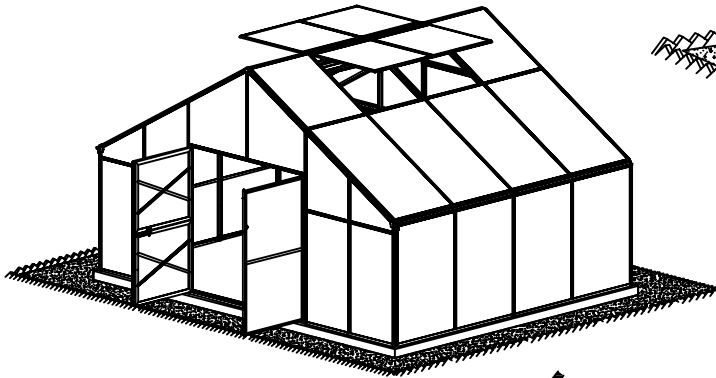

a = b

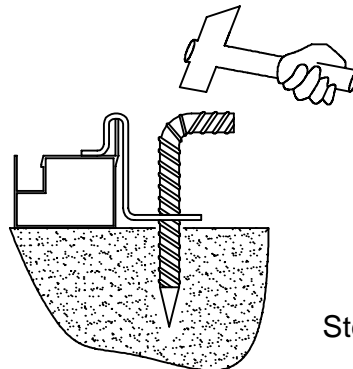

Steel pegs in soil

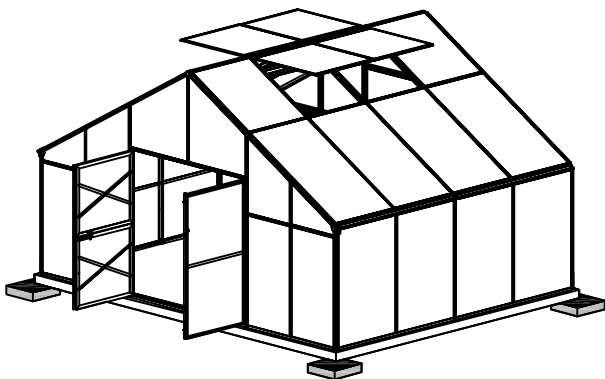

Support at the corners only is inadequate.

GM16

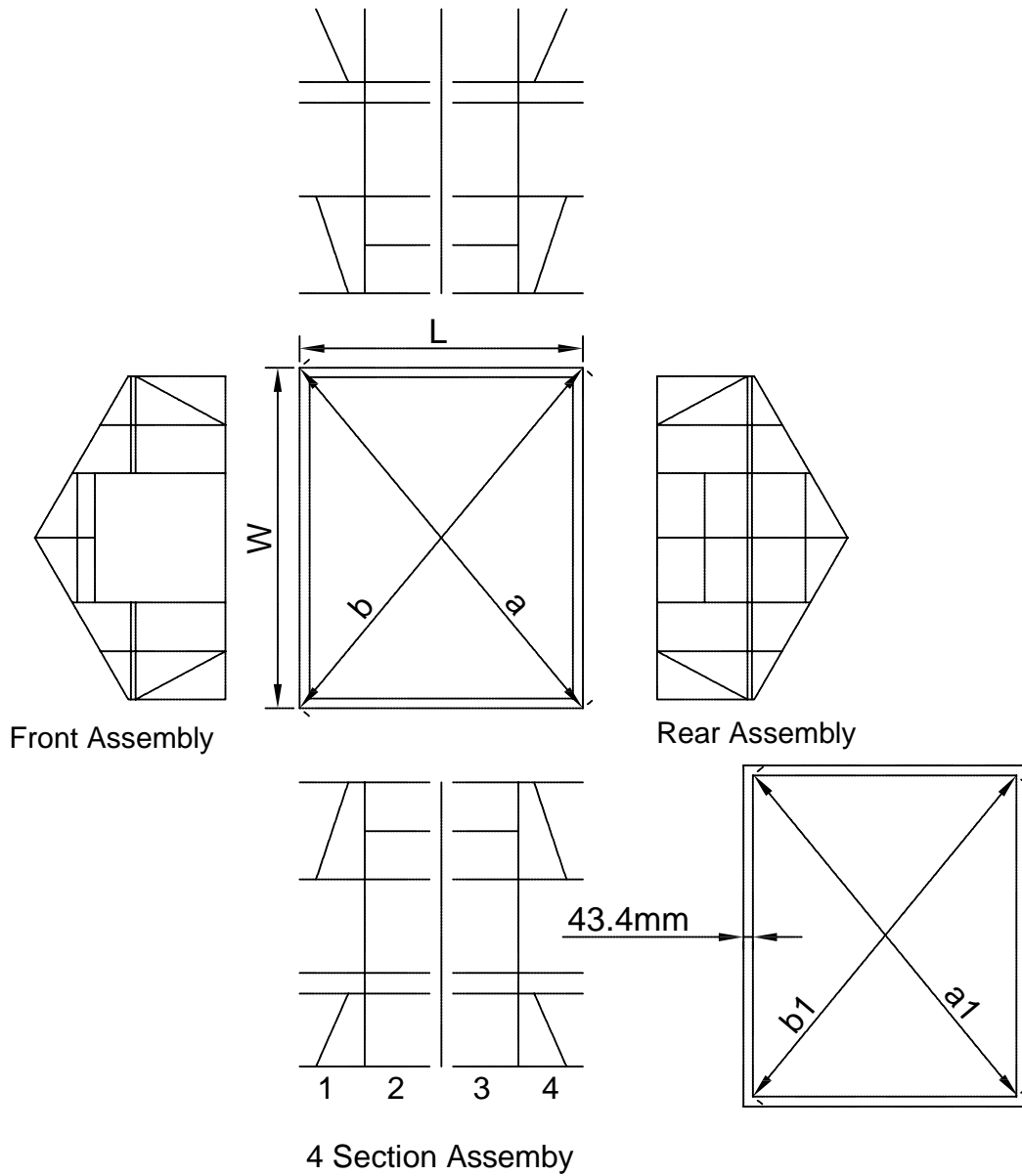

Dim/Model	GM16	GM16+Ext(1)	GM16+Ext(2)	GM16+Ext(3)	GM16+Ext(4)	GM16+Ext(5)	etc.
W(mm)	5061.8	5061.8	5061.8	5061.8	5061.8	5061.8	
L (mm)	4059.8	6061.8	8063.8	10065.8	12067.8	14069.8	
a=b(mm)	6488.7	7897.3	9520.8	11266.9	13086.4	14952.6	
a1=b1(mm)	6366.7	7775	9401.2	11150.4	12972.9	14841.7	

- * W= Outer Width of Base Profiles
- * L= Outer Length of Base Profiles
- * a=b= Outer Diagonal of Base Profiles
- * a1=b1= Inner Diagonal of Base Profiles

GM16+Ext(1)

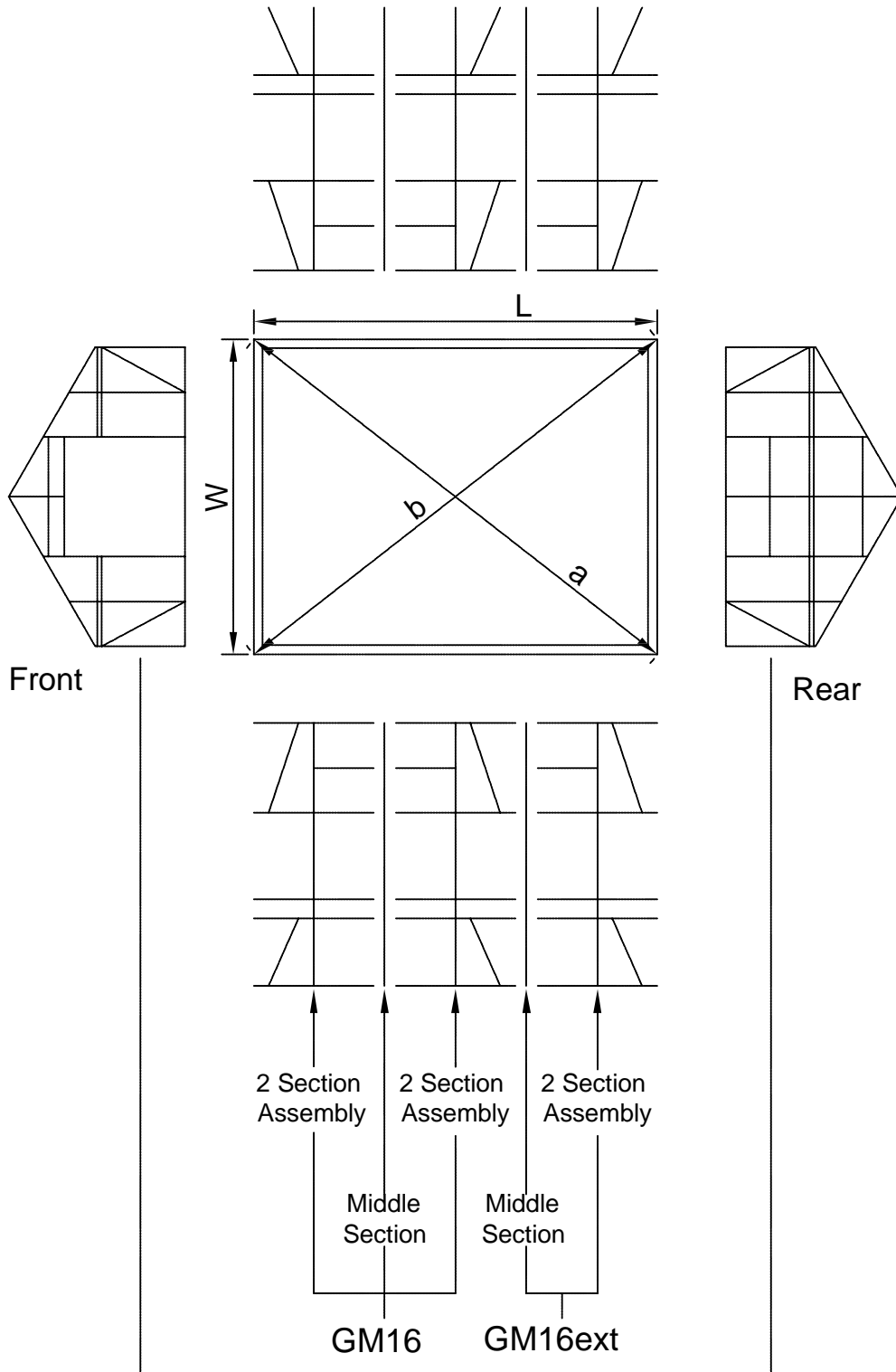



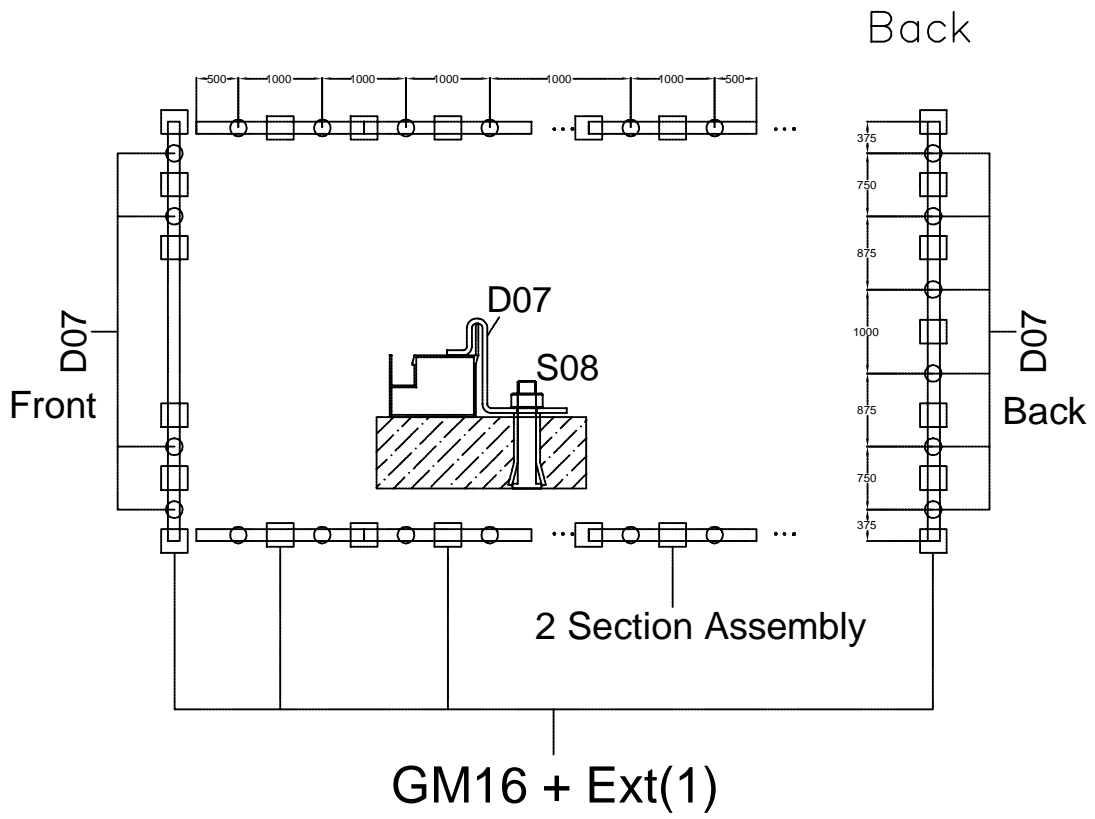







* The basic model, GM16, can be easily extended by adding a '2 Section Assembly' each time for a longer size.











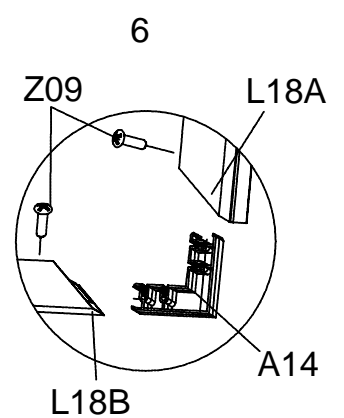
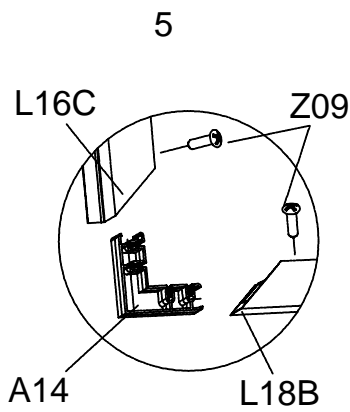
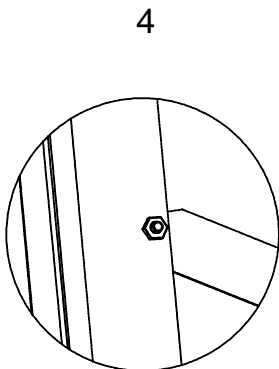
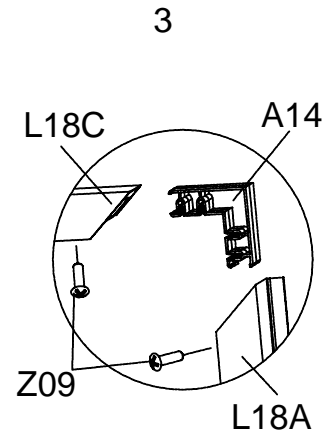
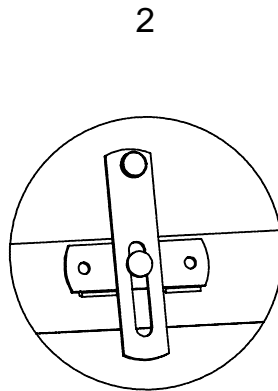
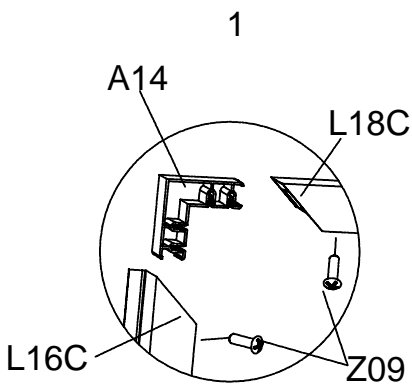
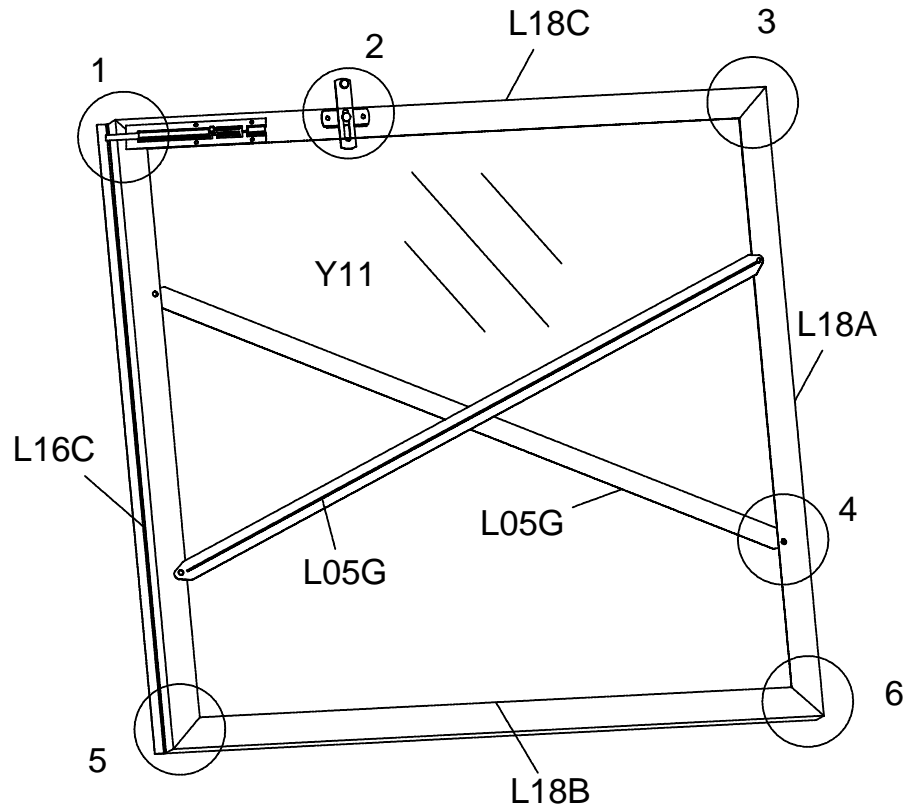

* This shows a layout for W05's positions where it is placed in the middle of PC panel for each section.

* All measurements in above diagram are in mm.

PART	NO.	QTY.
	L18A	1
	L18B	1
	L18C	1
	L16C	1
	L05G	2
	Y11	1
	A14	4
	Z09	8
	Ø5X15	
	S05	4
	M6X12	
	M03	4
	M6	









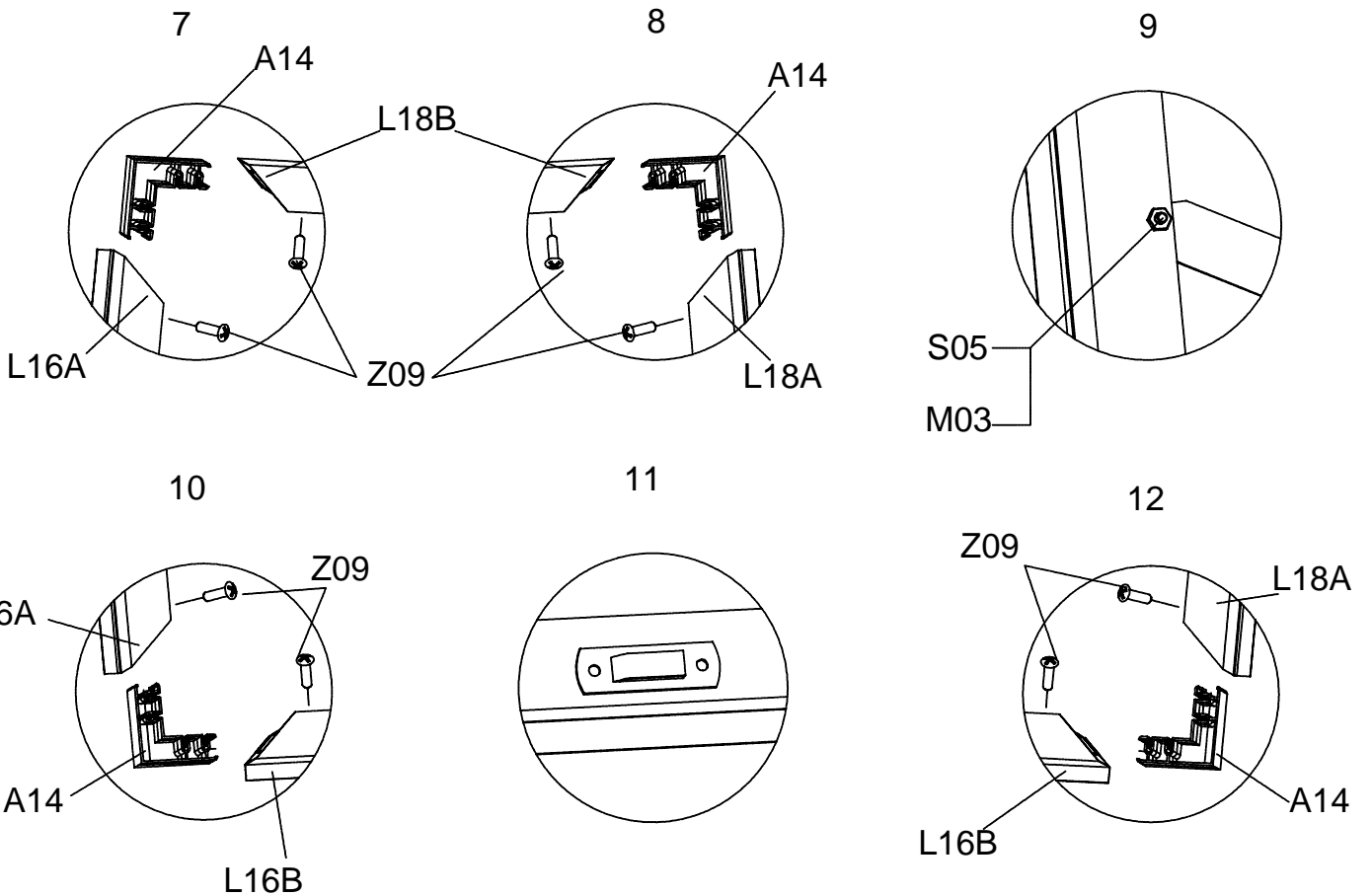
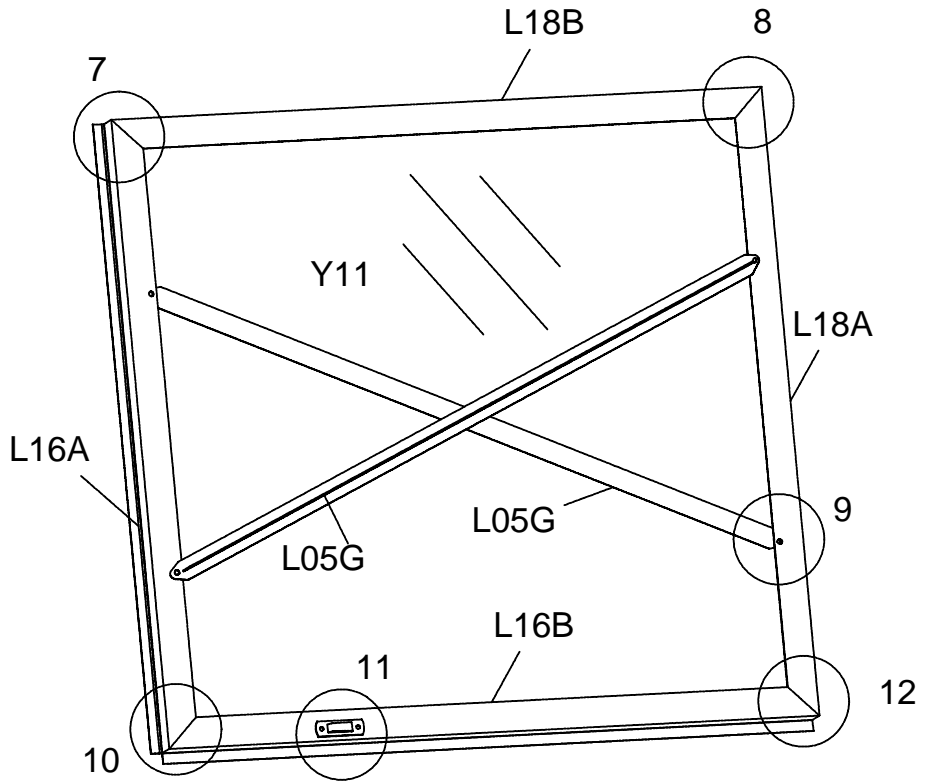

Door 1 Assembly



PART	NO.	QTY.
	L18A	1
	L18B	1
	L16A	1
	L16B	1
	L05G	2
	Y11	1
	A14	4
	Z09	8
	Ø5X15	
	S05	4
	M6X12	
	M03	4
	M6	







Door 2 Assembly

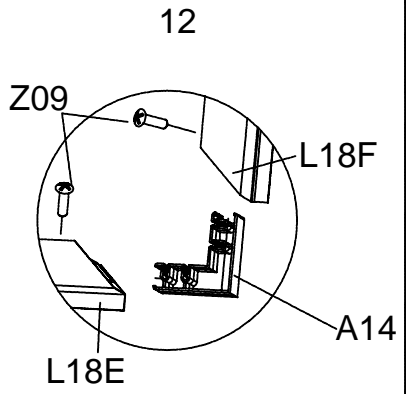
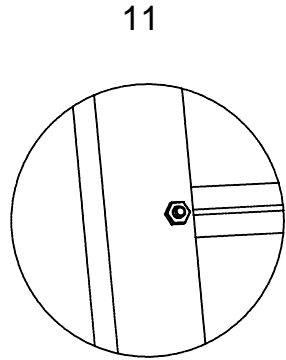
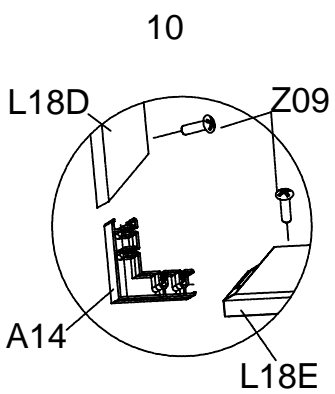
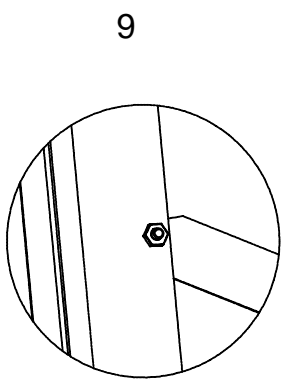
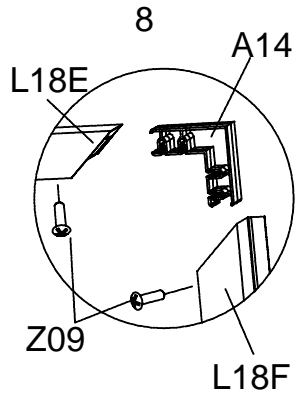
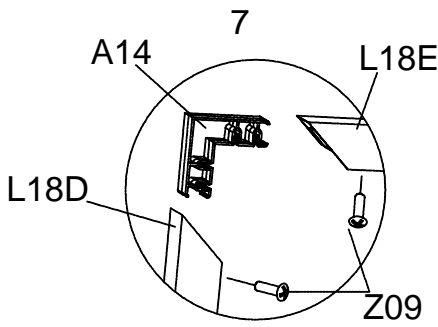
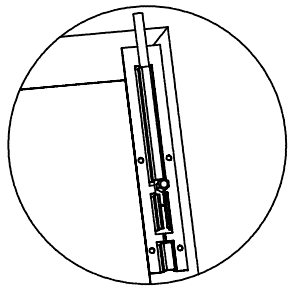
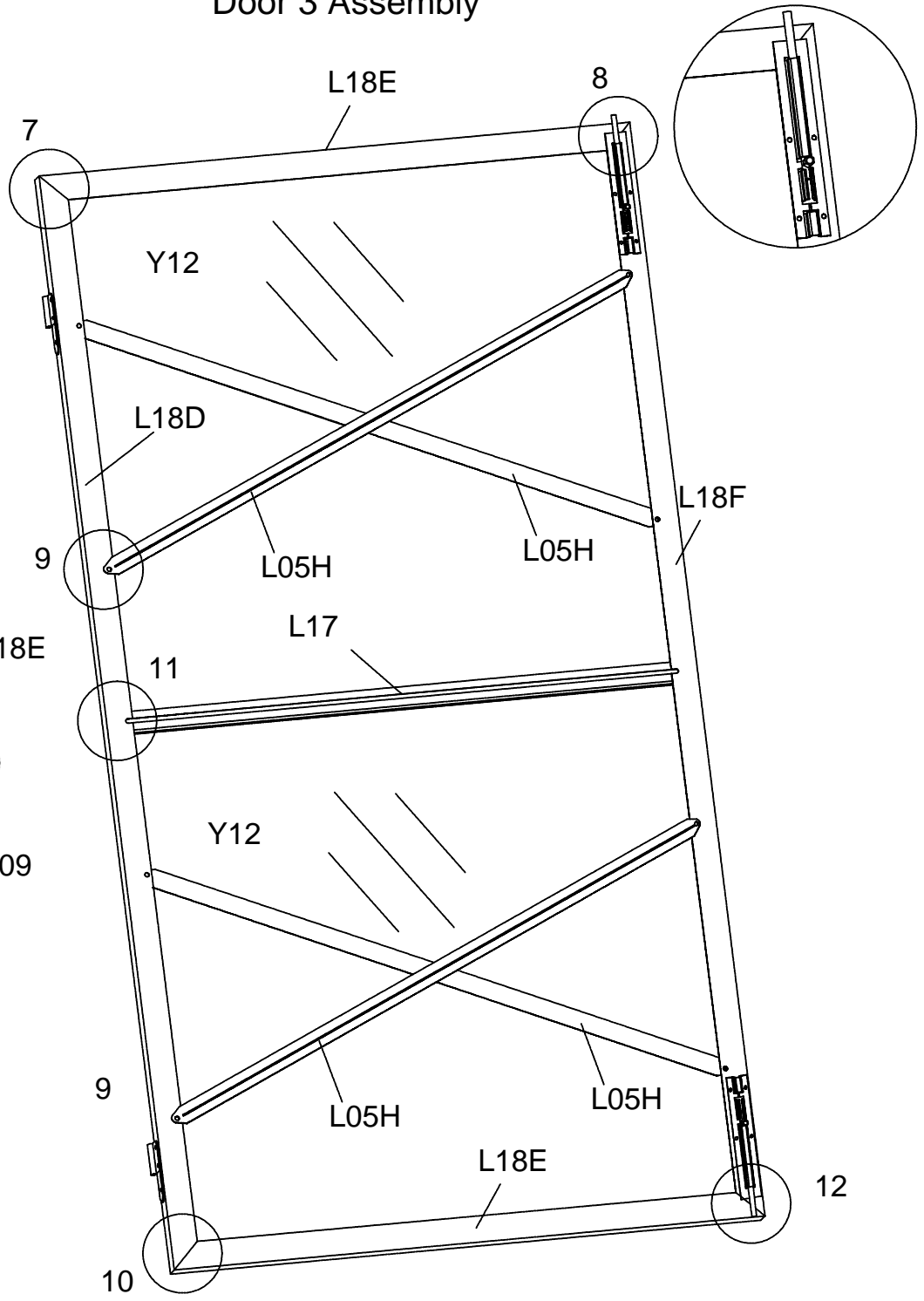

PART	NO.	QTY.
	L18D	1
	L18E	2
	L18F	1
	L17	1
	L05H	4
	Y12	2
	A14	4
	Z09	8
	Ø5X15	
	S05	10
	M6X12	
	M03	10
	M6	







Door 3 Assembly

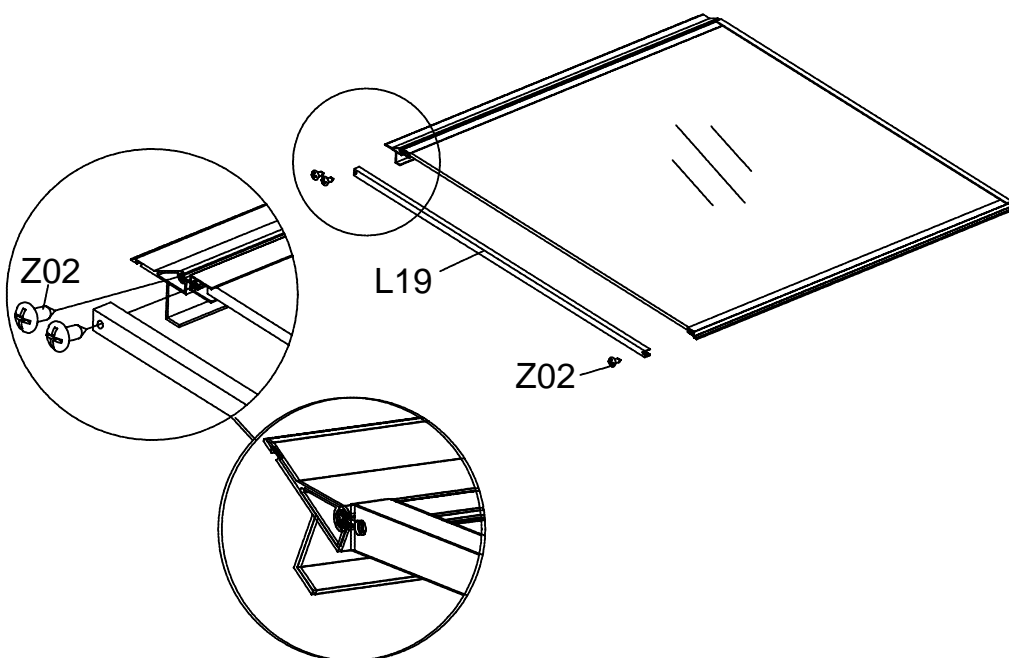
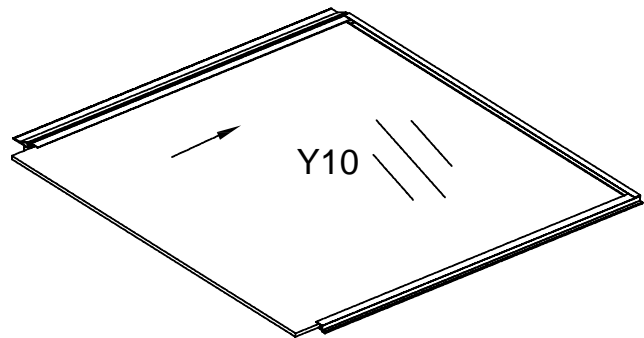
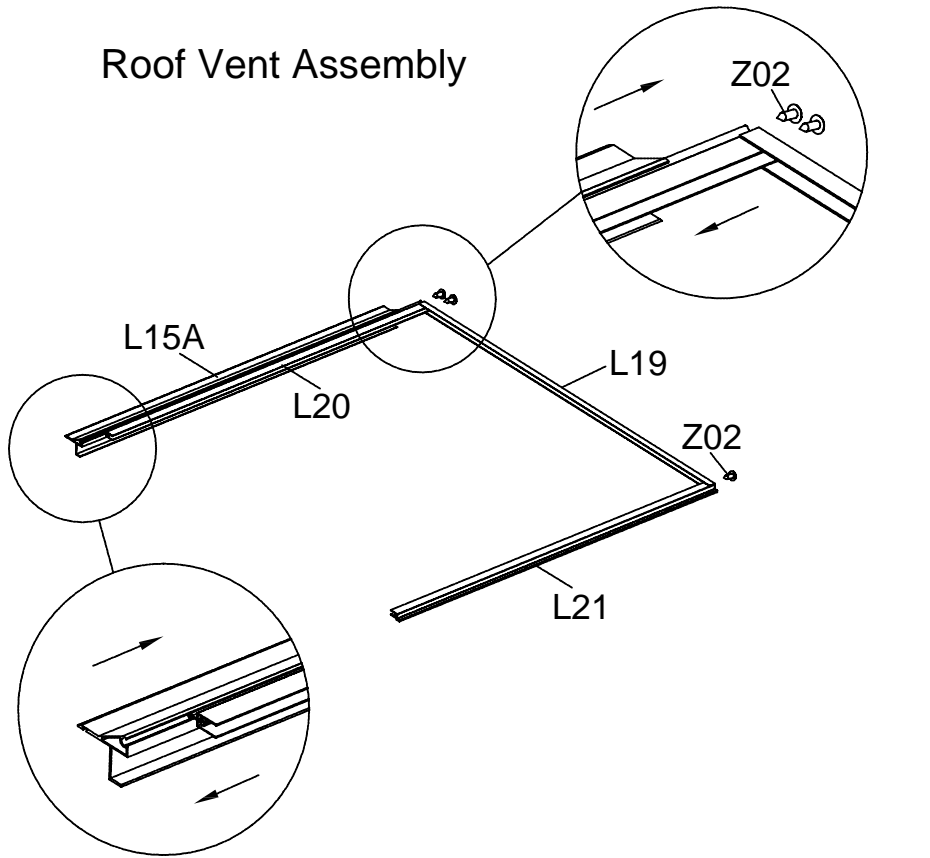

PART	NO.	QTY.
	L15A	1
	L19	2
	L20	1
	L21	1
	A01	2
	Z02 Ø4X16D	6
	Y10	1

Roof Vent Assembly



PART	NO.	QTY.
	L08A	4
	L08B	6
	A52	2
	A53	2
	A54	6
	J01R/L	2/2
	J03	6

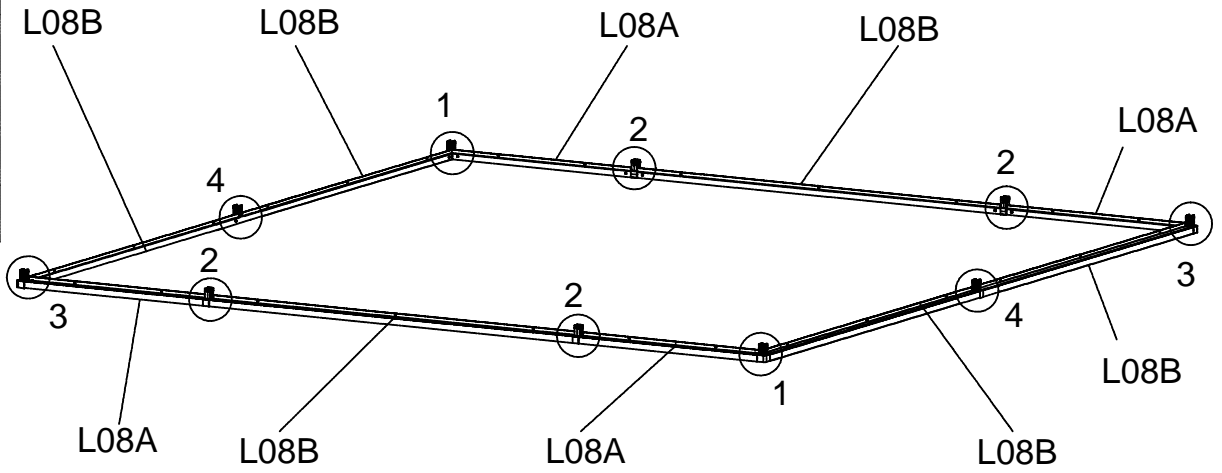

make sure you pay close attention to the direction of the pins

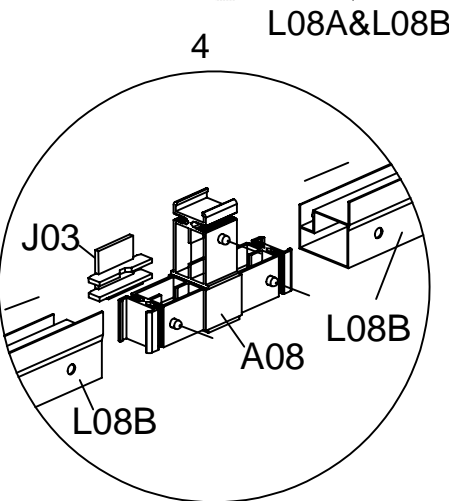
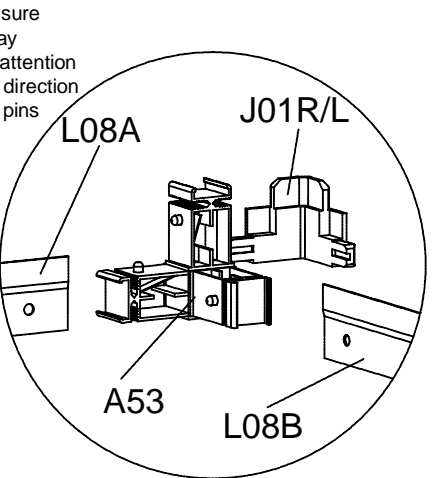
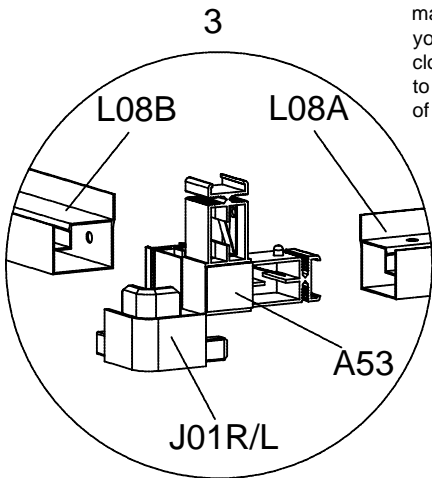
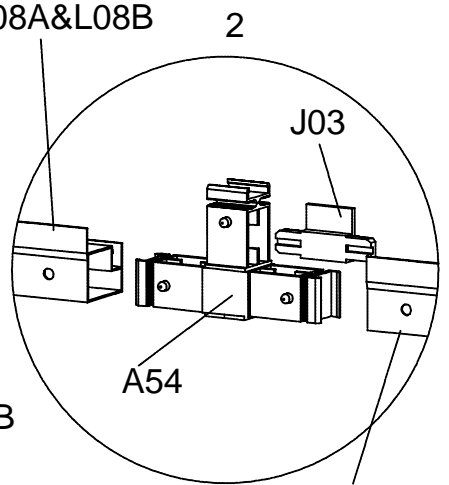
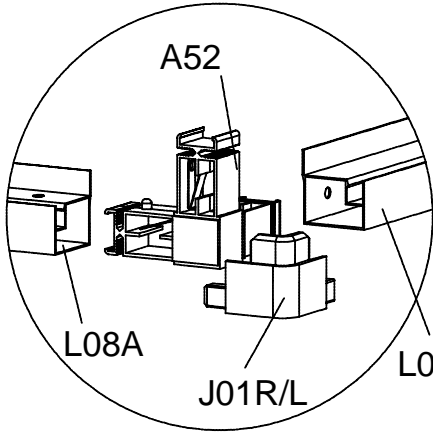
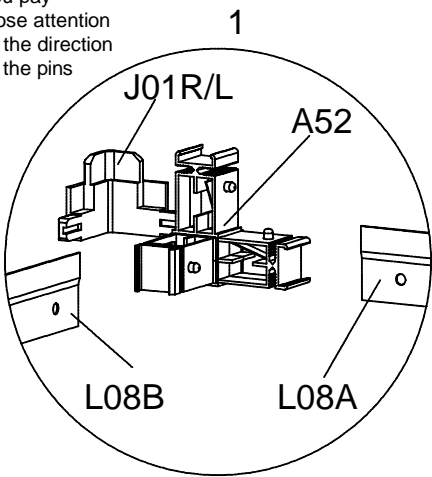



make sure you pay close attention to the direction of the pins

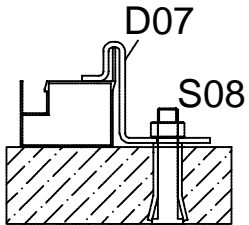







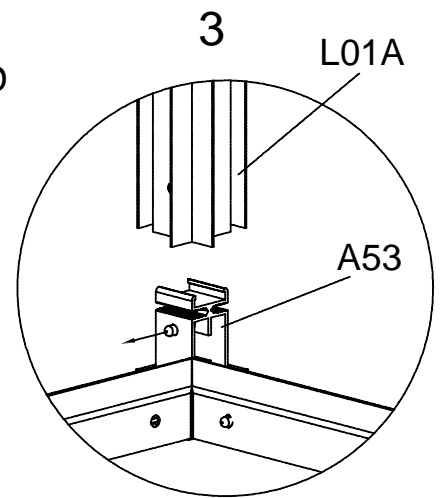
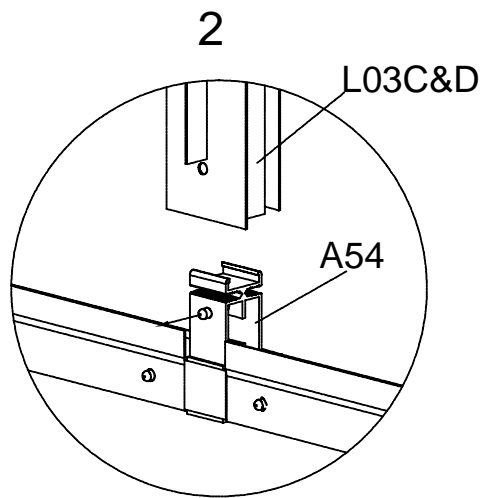
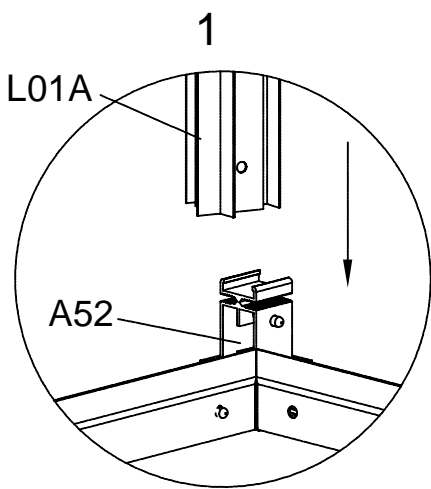
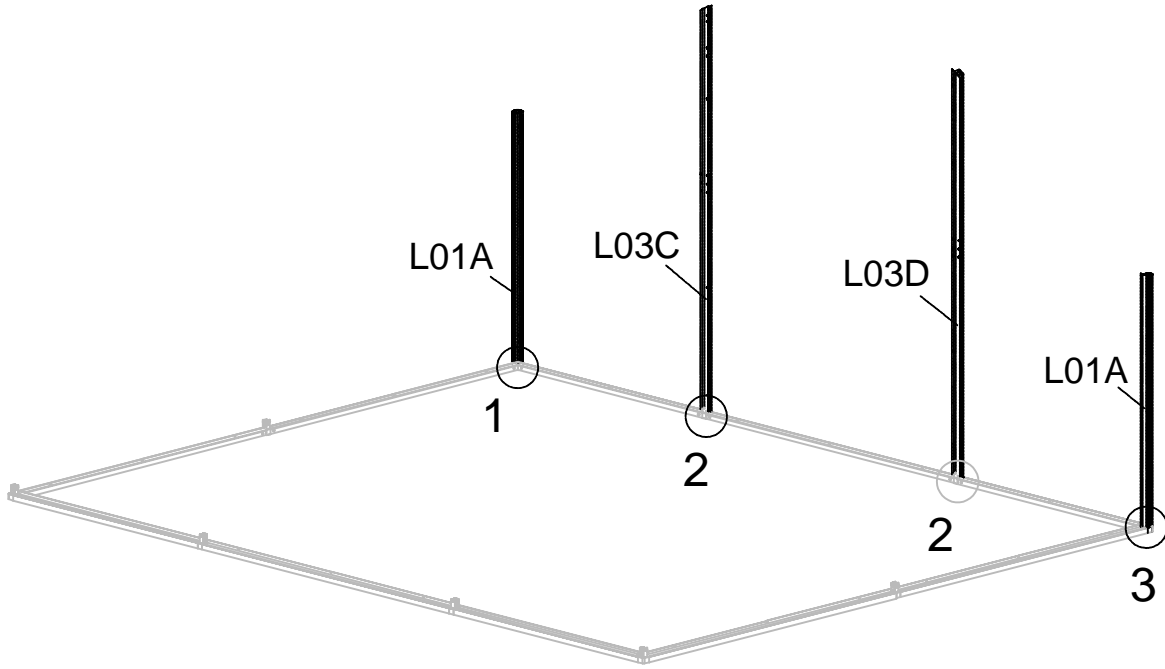

Assemble all D07 followed by previous Page 11 after each base profile is connected.







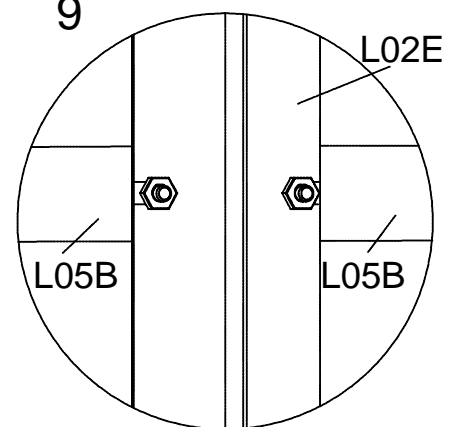
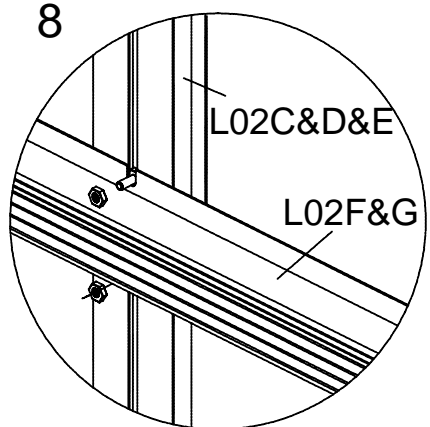
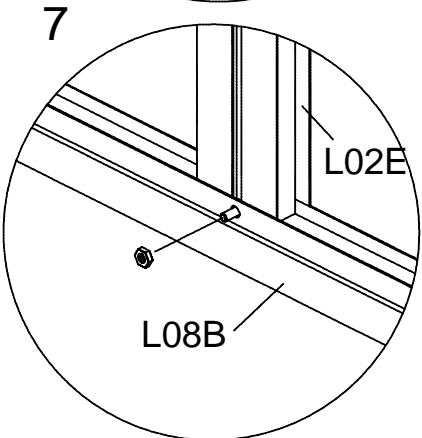
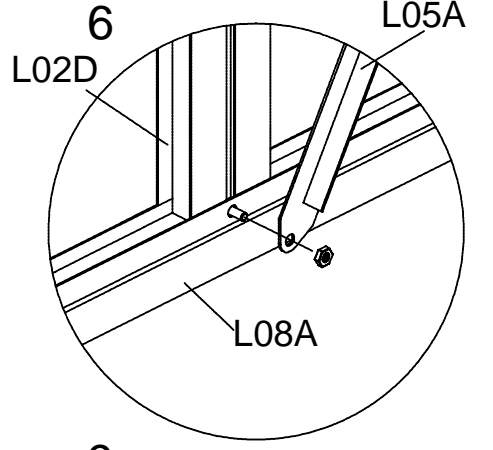
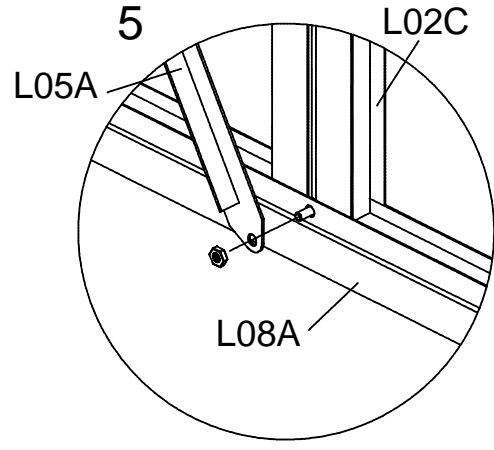
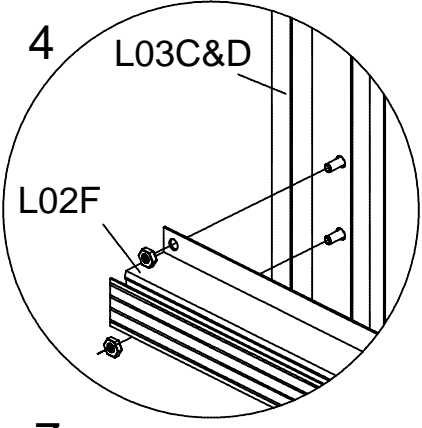
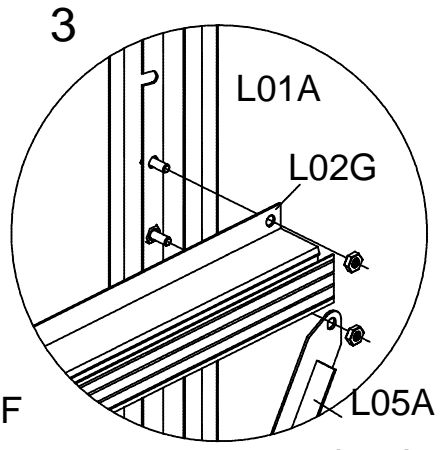
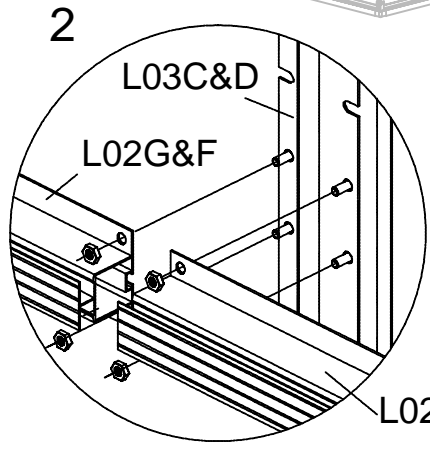
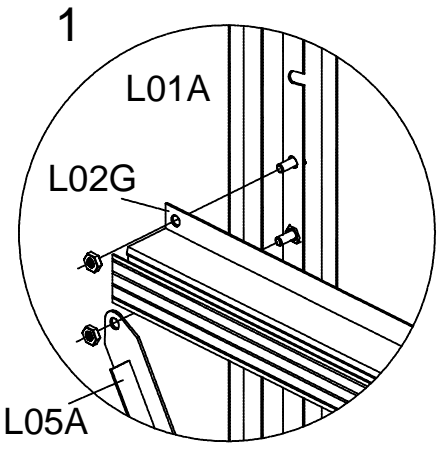
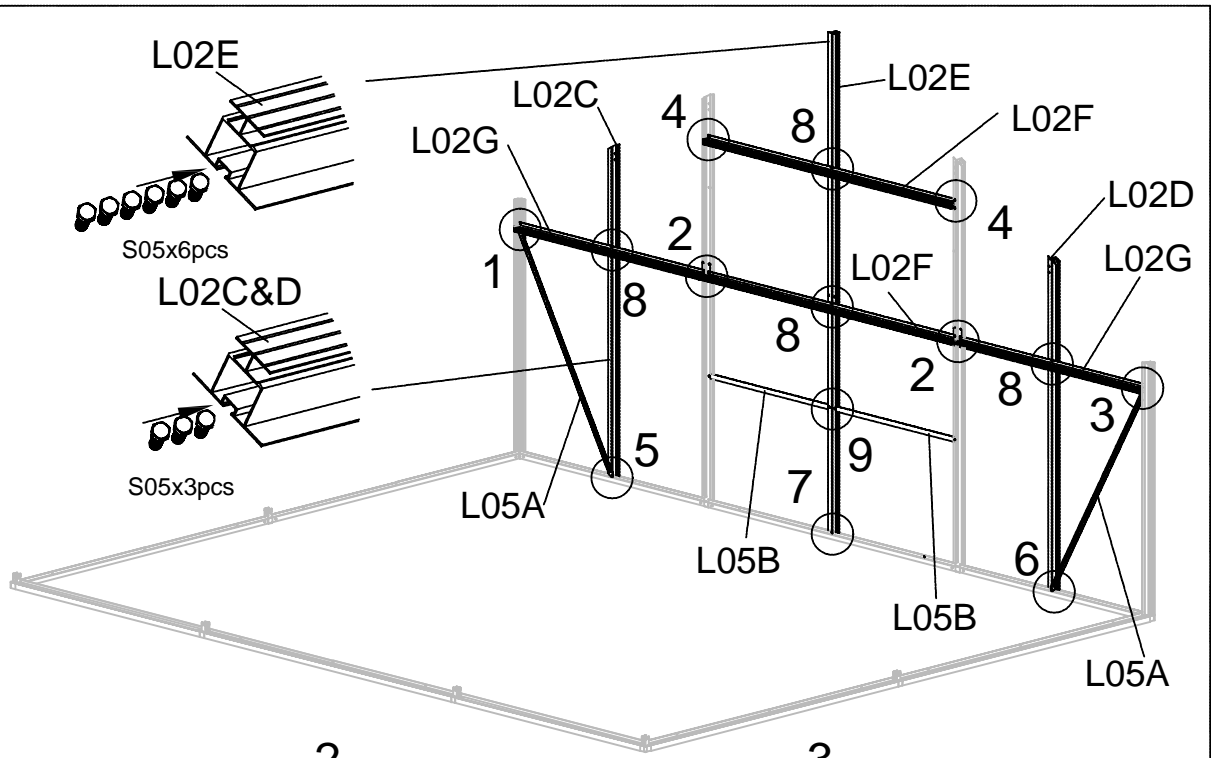

must connect all plastic parts (J03 and J01 R/L) before completing this step

PART	NO.	QTY.
	L01A	2
	L03C	1
	L03D	1









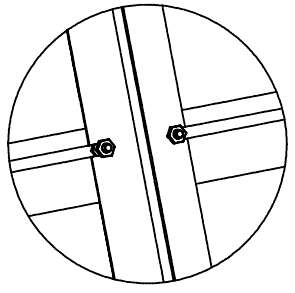
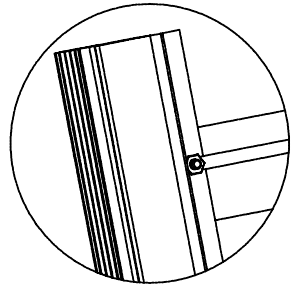
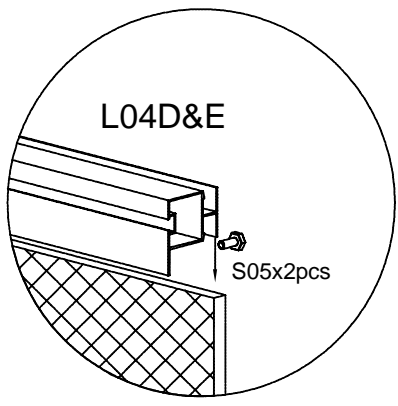
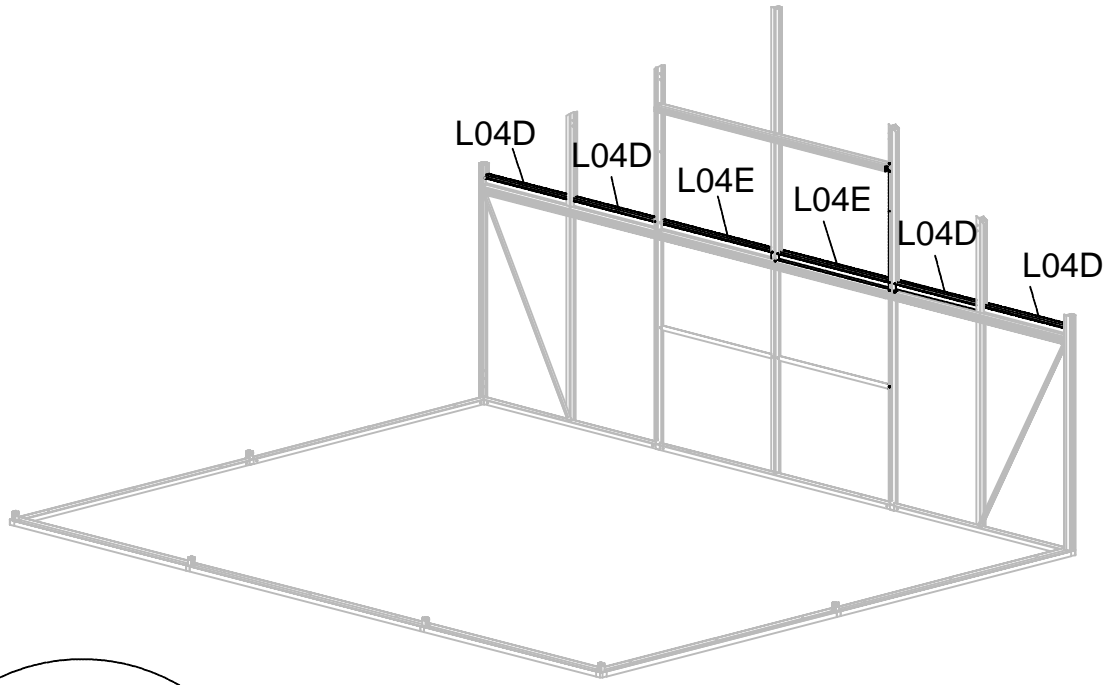
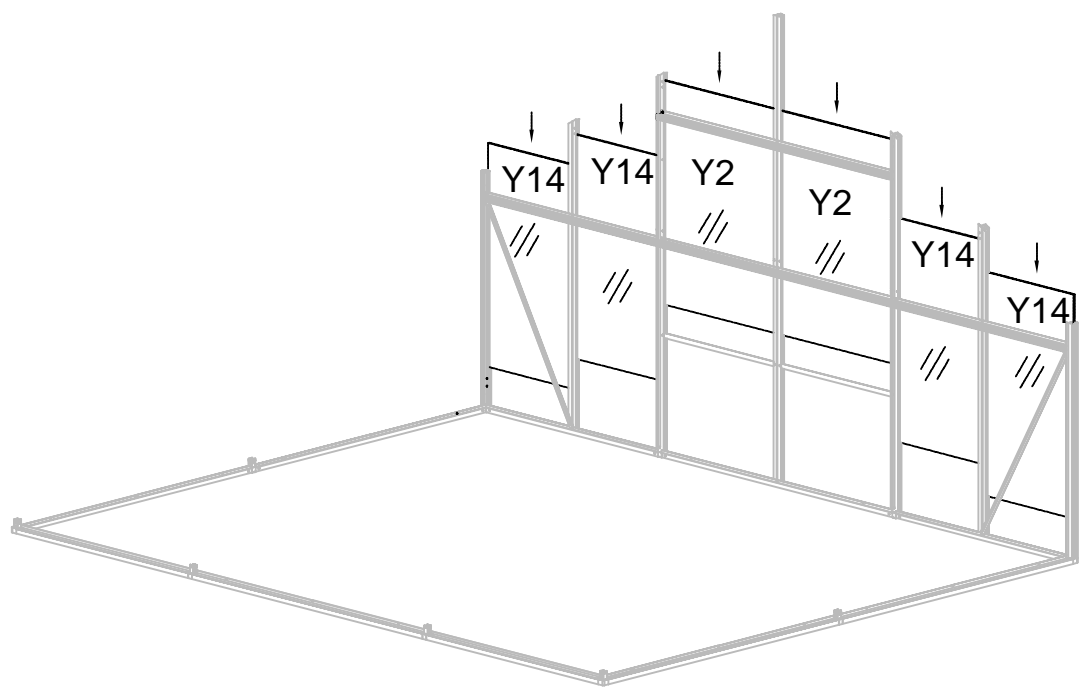





PART	NO.	QTY.
	L02C	1
	L02D	1
	L02E	1
	L02F	2
	L02G	2
	L05A	2
	L05B	2
	S05	32
	M6X12	
	M03	31
	M6	



PART	NO.	QTY.
	L04D	4
	L04E	2
	Y2	2
	Y14	4
	S05	16
	M6X12	
	M03	16
	M6	



Slide 2 x S05 into each L04D & E, and put each profile onto the edge of each PC panel, then tighten all profiles at each end with S05.



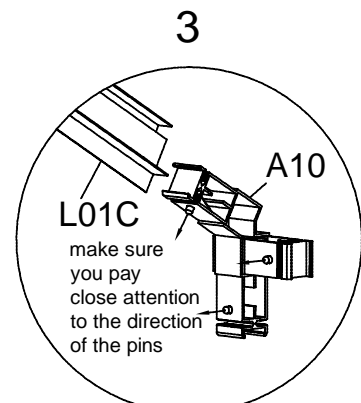
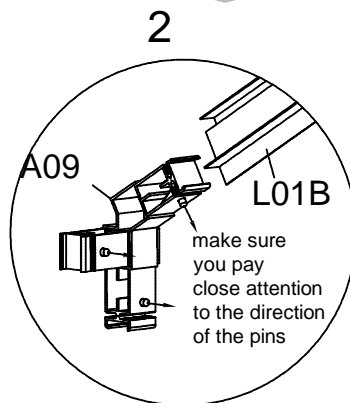
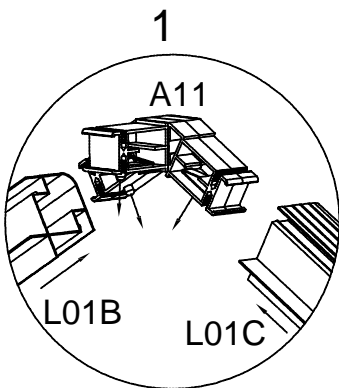
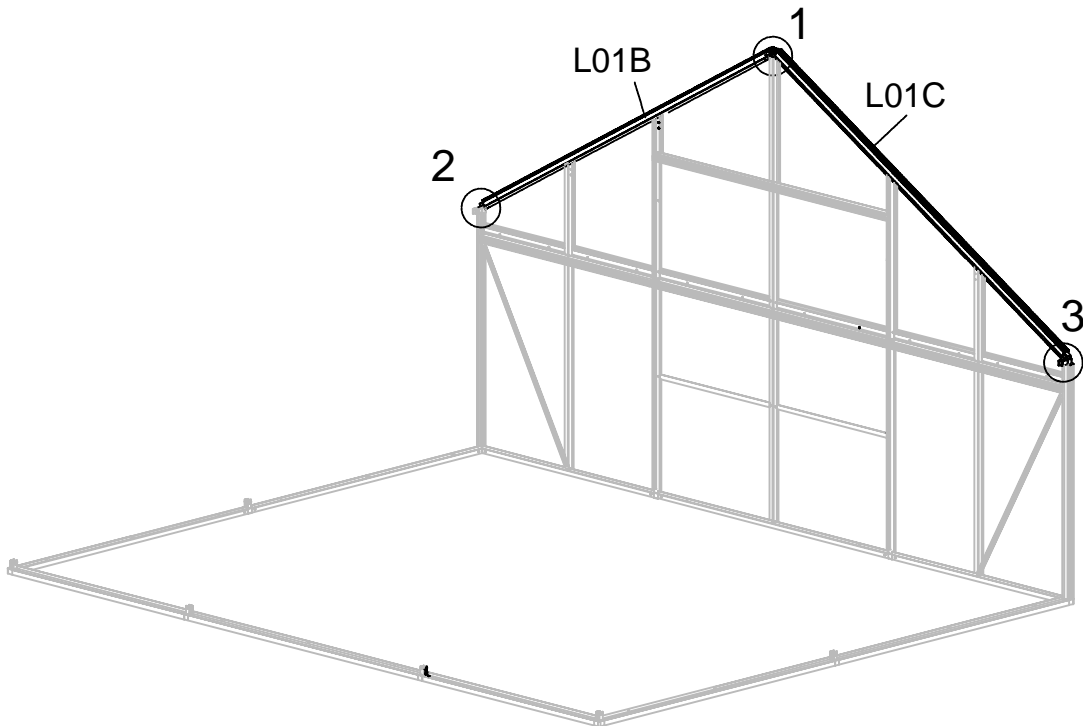
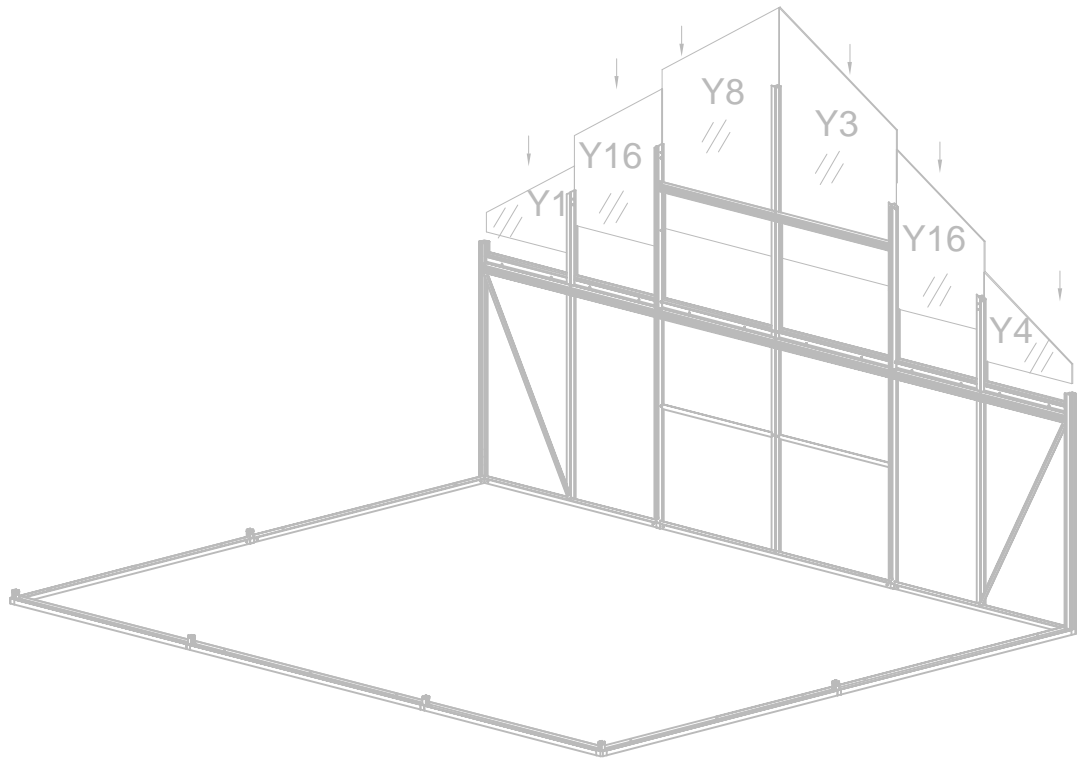

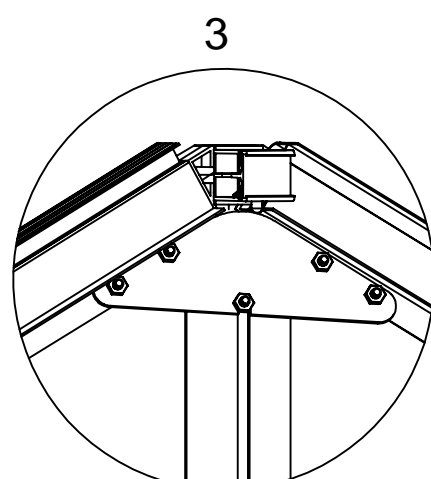
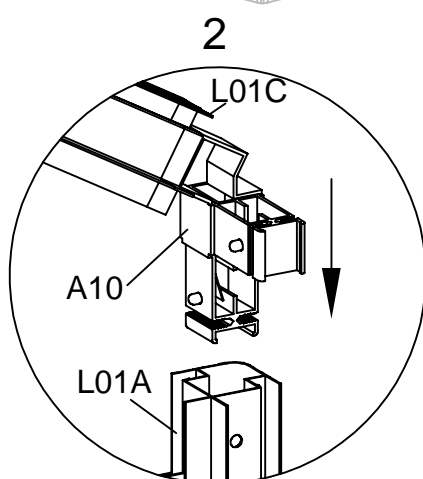
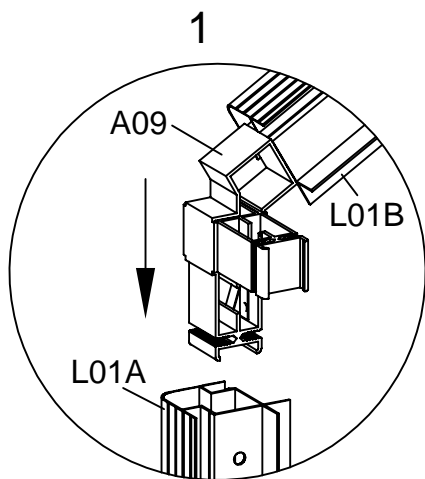
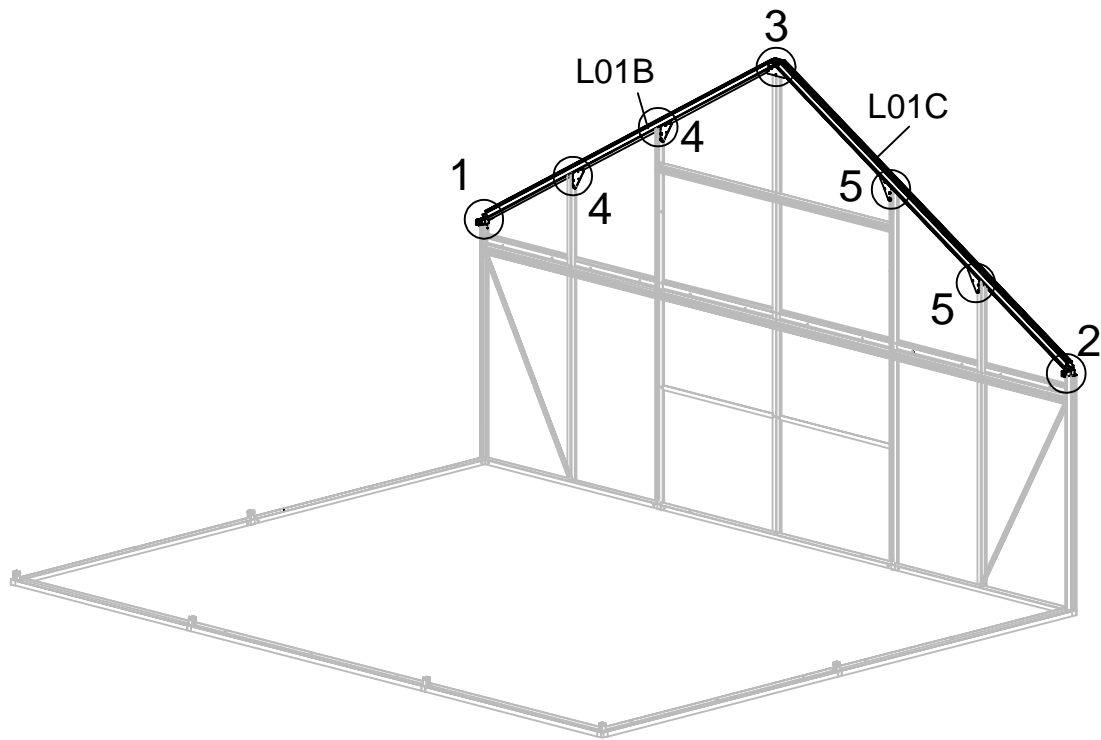

PART	NO.	QTY.
	L01B	1
	L01C	1
	A09	1
	A10	1
	A11	1
	D17	3
	Y1	1
	Y3	1
	Y4	1
	Y8	1
	Y16	2
	S05	12
	M6X12	
	M03	12
	M6	

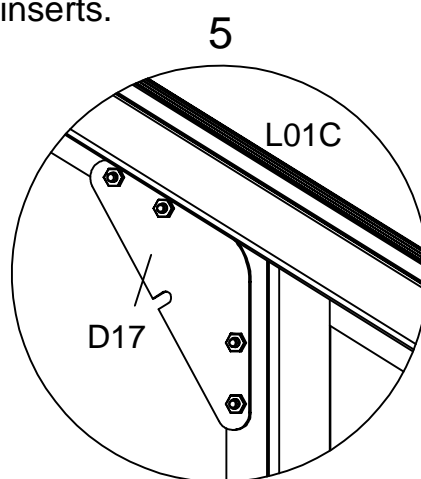
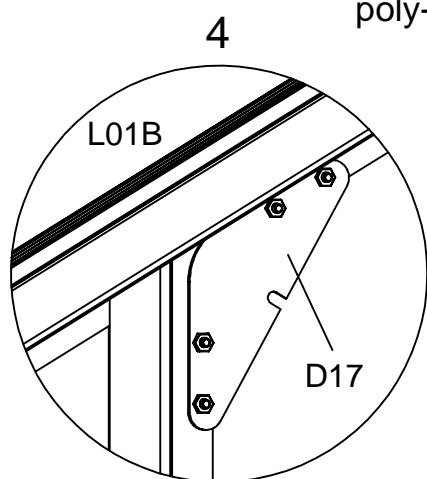







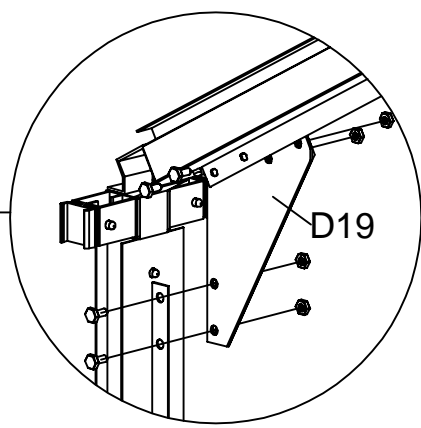
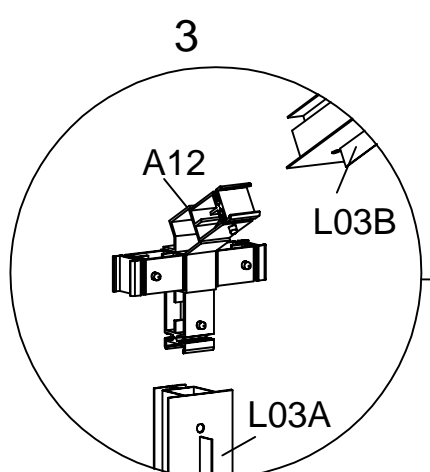
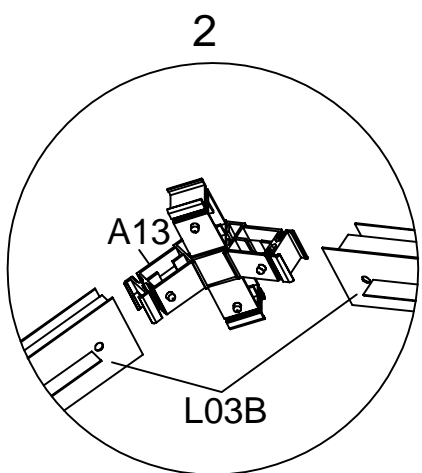
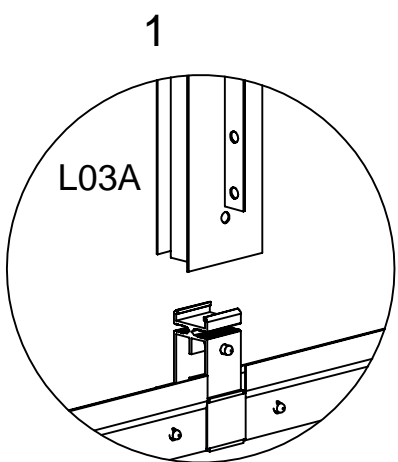
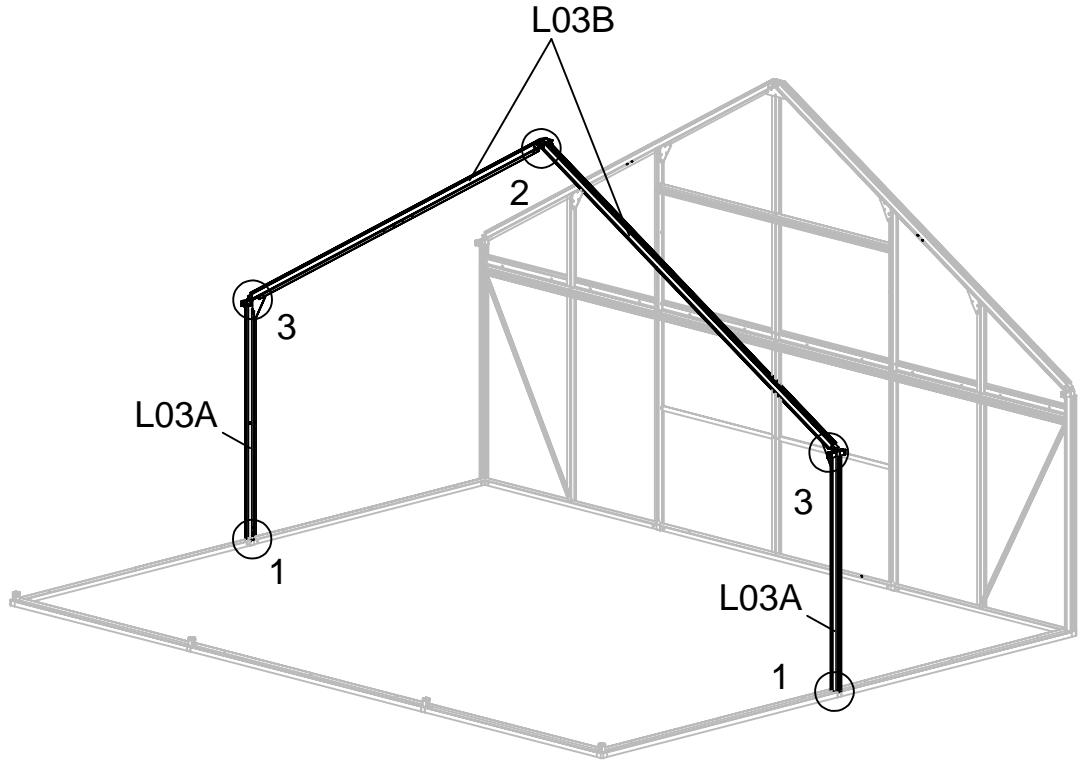

Note: please insert upper roof supports but, do not lock in place until you have aligned the poly-carbonate inserts.



PART	NO.	QTY.
	L03A	2
	L03B	2
	A12	2
	A13	1
	D19	2
	S05	8
	M6X12	
	M03	8
	M6	





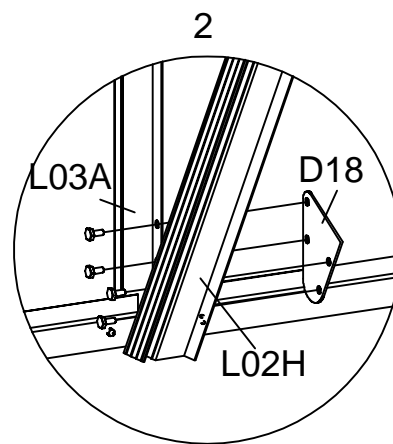
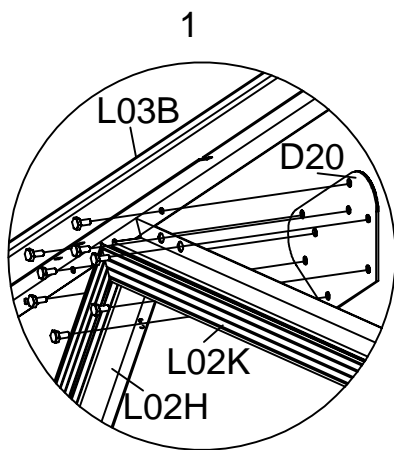
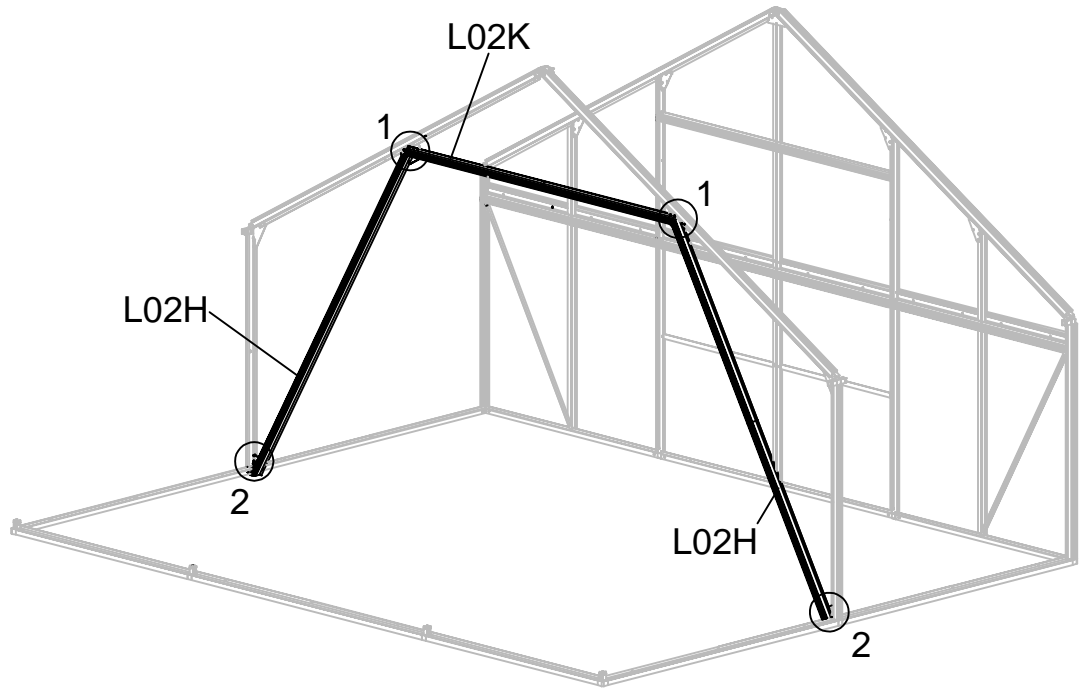

PART	NO.	QTY.
	L02H	2
	L02K	1
	D18	2
	D20	2
	S05	24
	M6X12	
	M03	24
	M6	

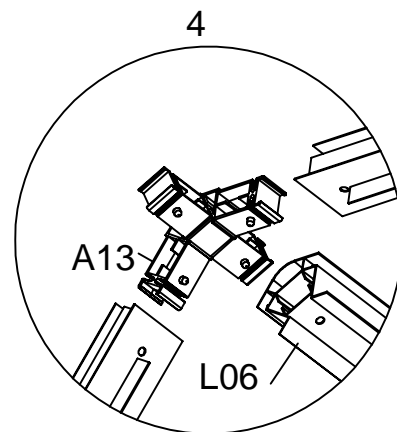
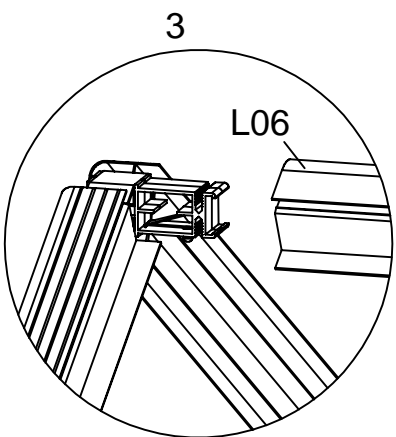
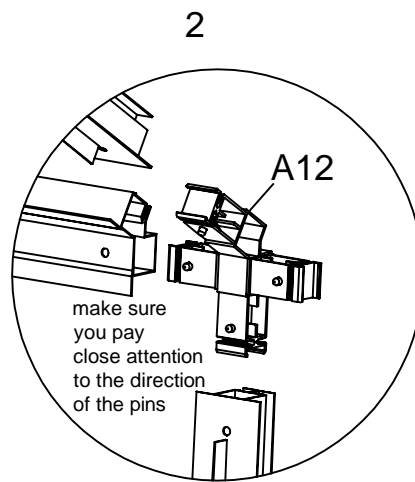
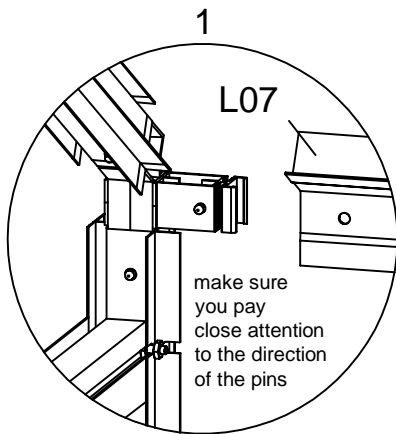
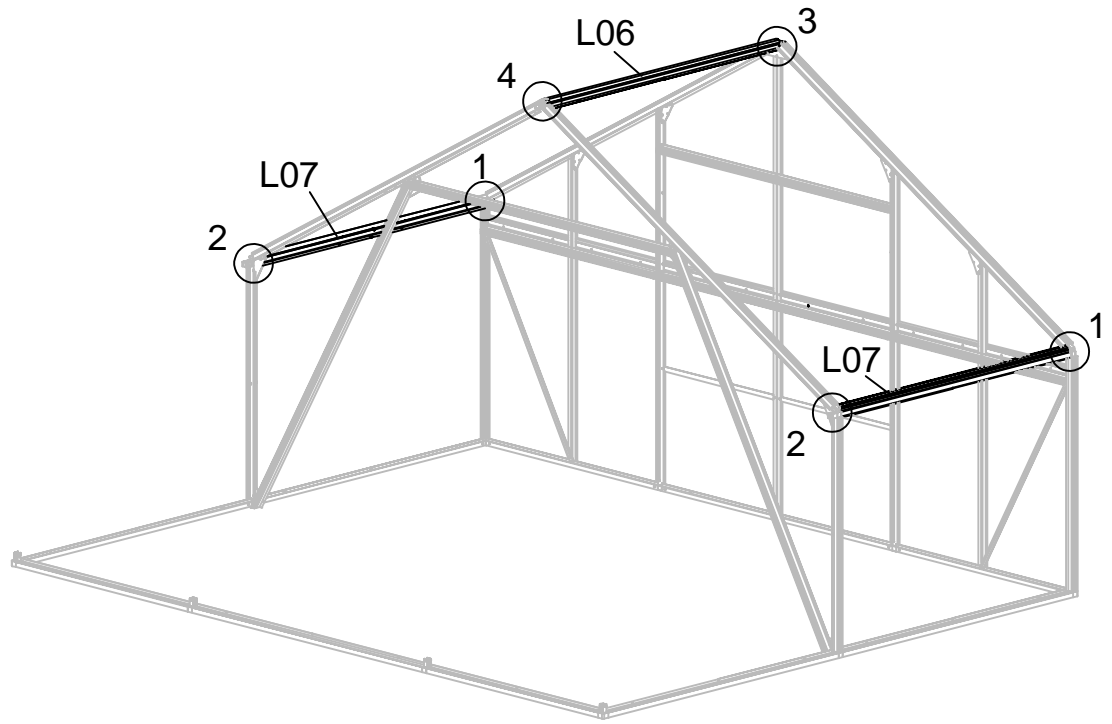







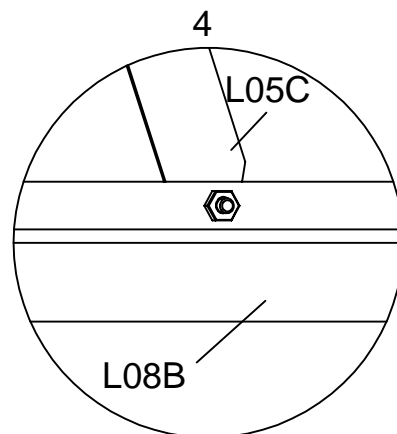
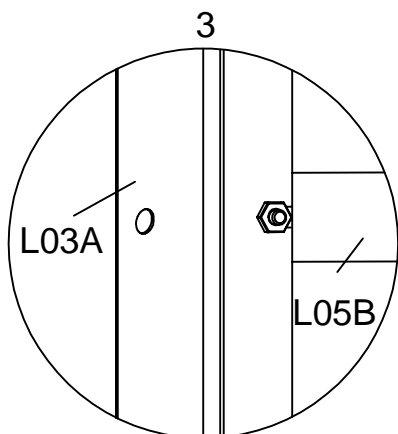
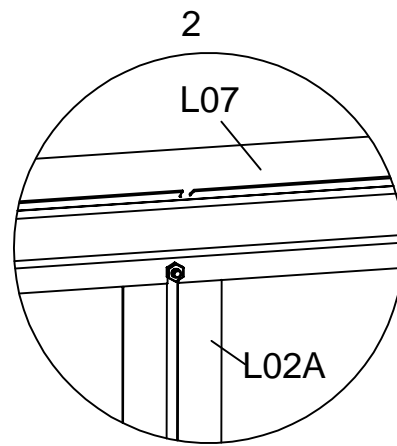
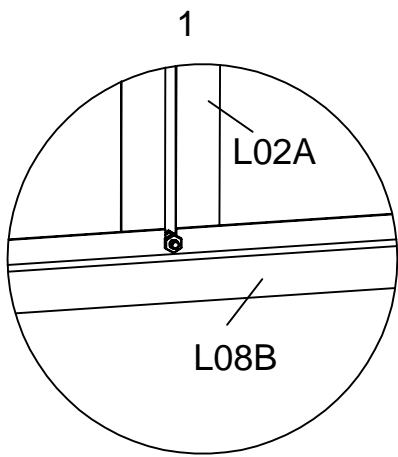
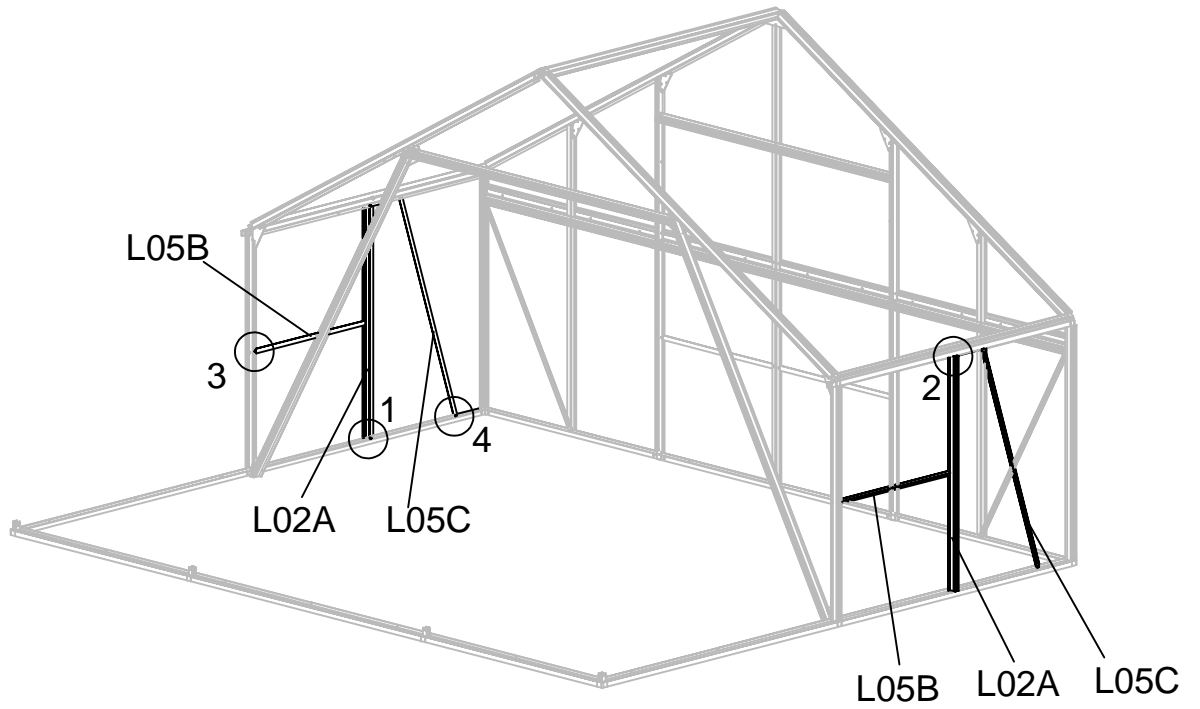





PART	NO.	QTY.
	L06	1
	L07	2



PART	NO.	QTY.
	L02A	2
	L05B	2
	L05C	2
	S05	6
	M6X12	
	M03	6
	M6	





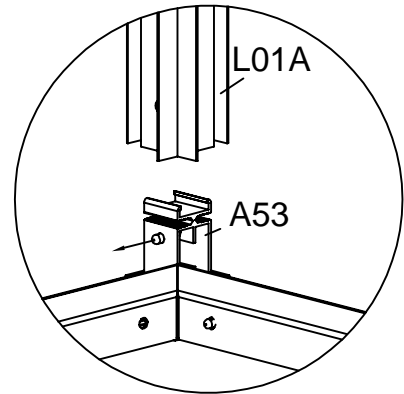
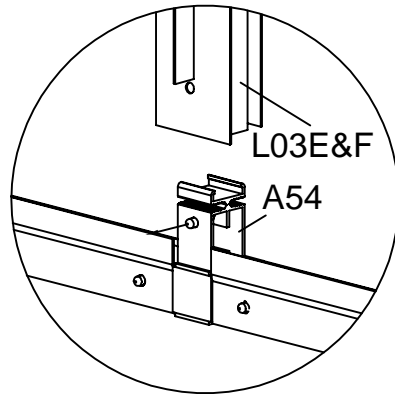
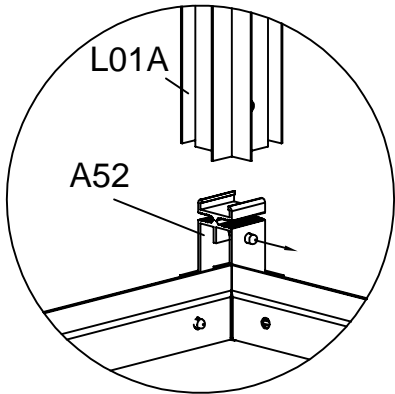
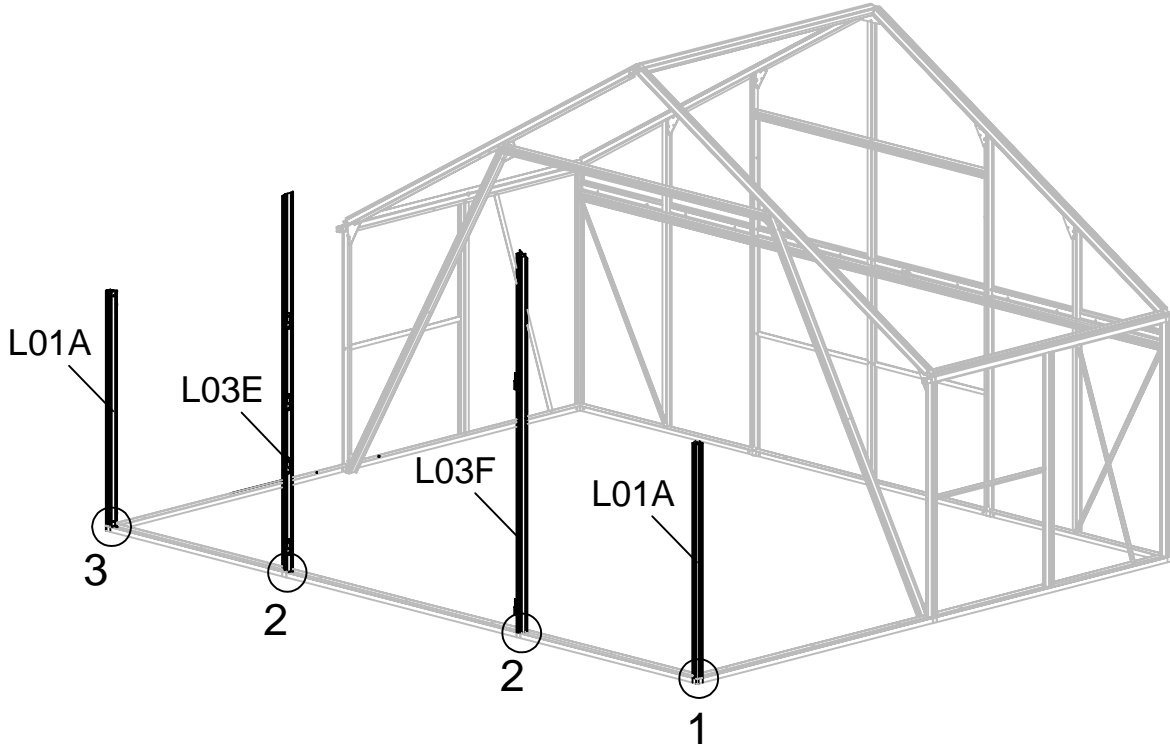

PART	NO.	QTY.
	L01A	2
	L03E	1
	L03F	1
	L02C	1
	L02D	1
	L02G	2
	L02F	1
	L04A	1
	L04C	1
	L05A	2
	D04	1
	S05	22
	M6X12	
	M03	22
	M6	

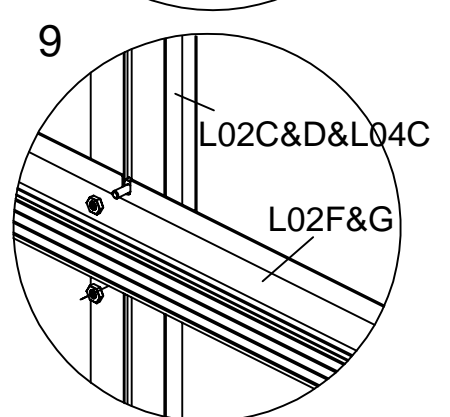
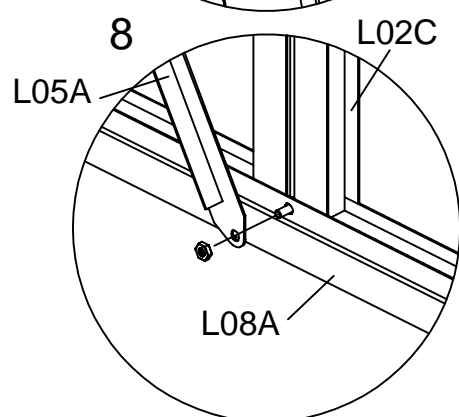
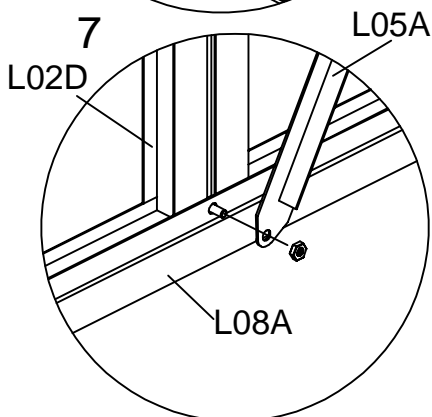
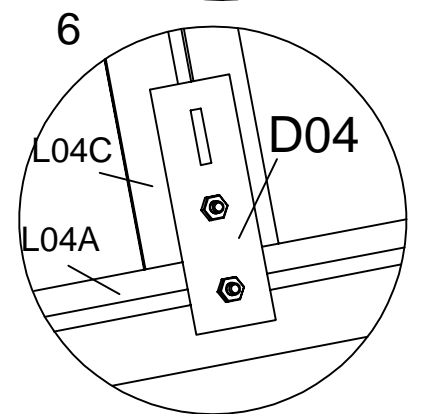
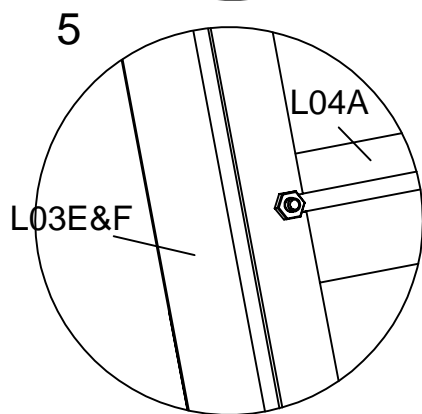
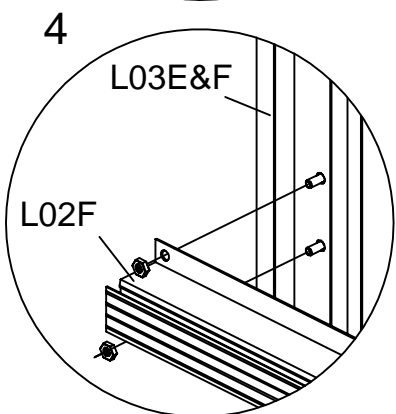
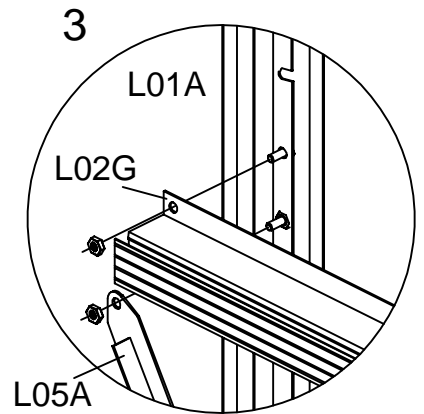
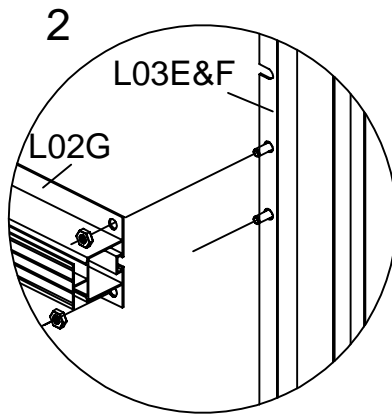
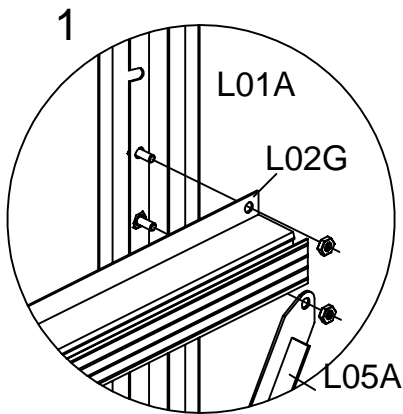
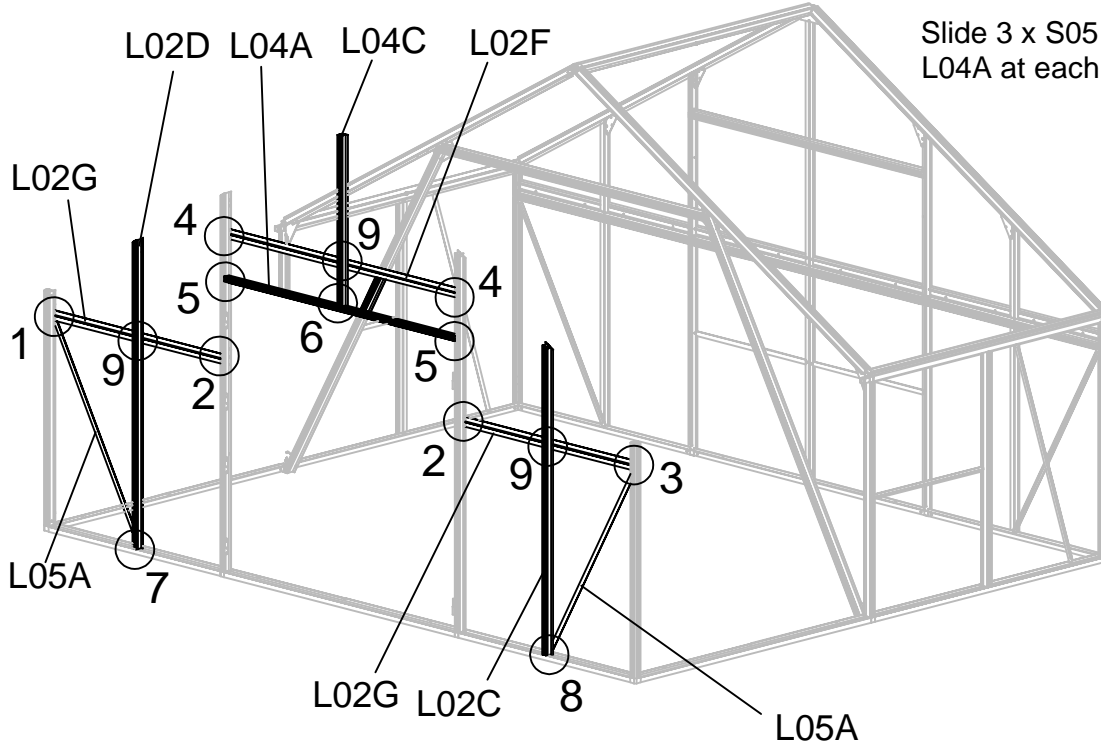







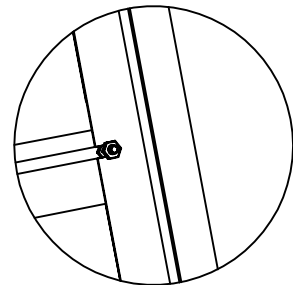
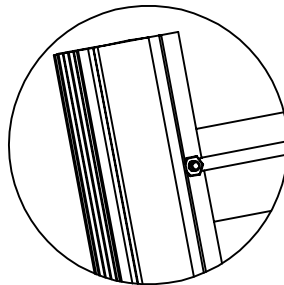
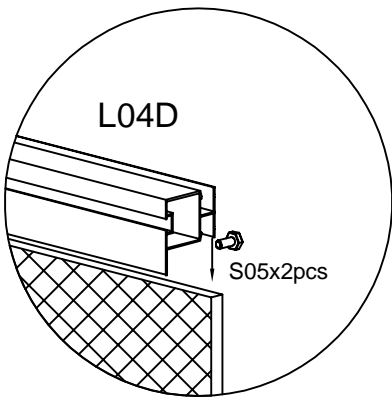
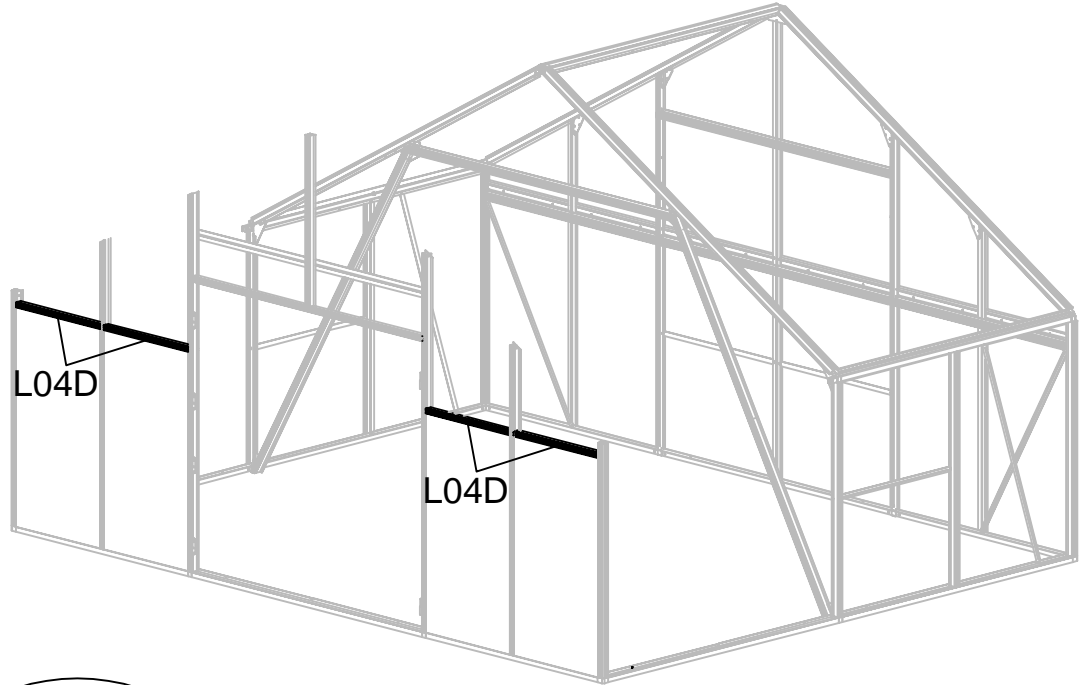
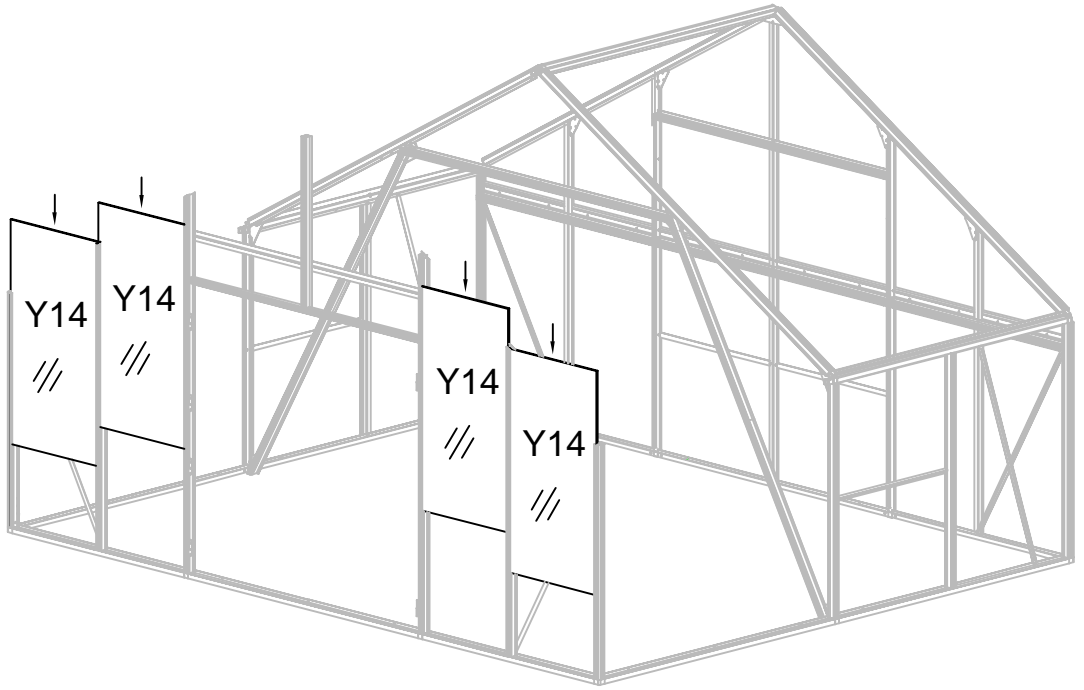





Slide 3 x S05 into L04A, and tighten L04A at each end with S05.



PART	NO.	QTY.
	Y14	4
	L04D	4
	S05	8
	M6X12	
	M03	8
	M6	





Slide 2 x S05 into each L04D and put each L04D onto the edge of each PC panel, then tighten all profiles at each end with S05.

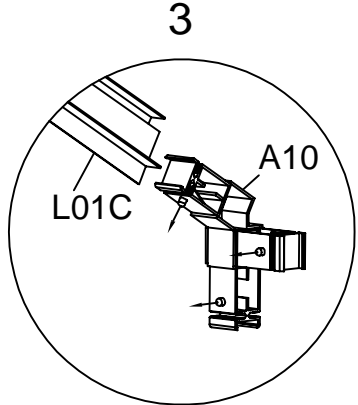
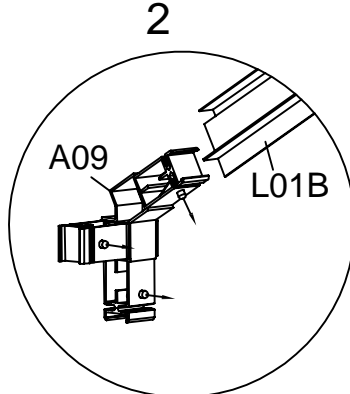
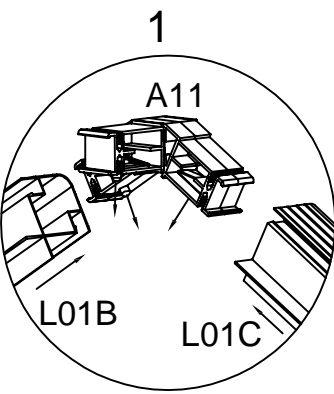
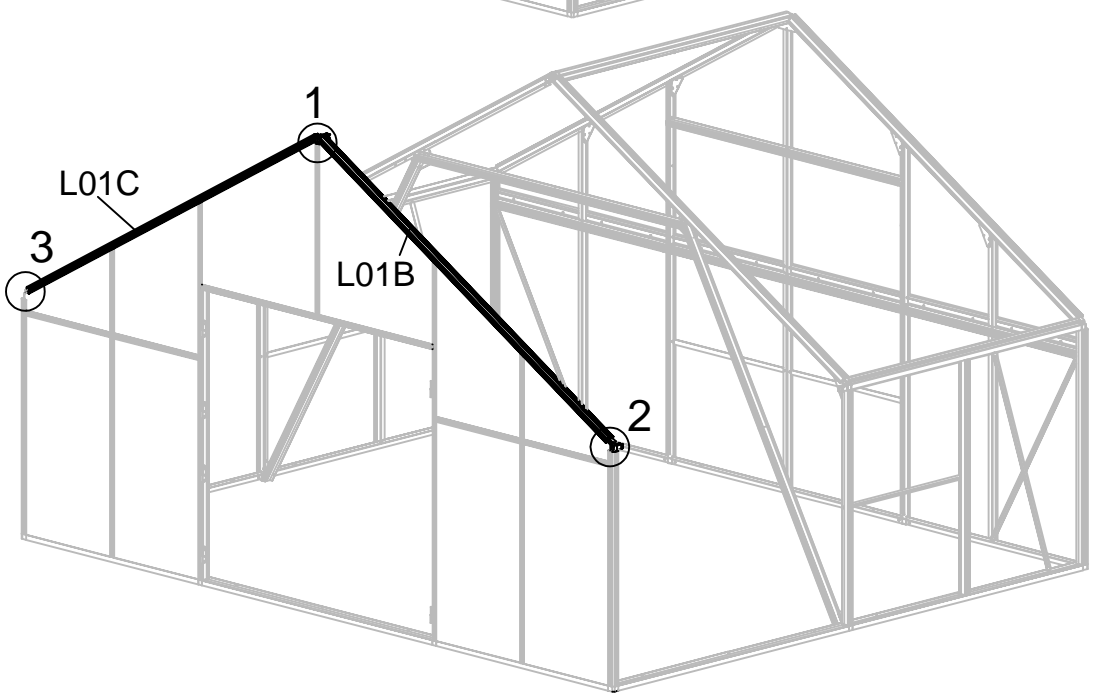
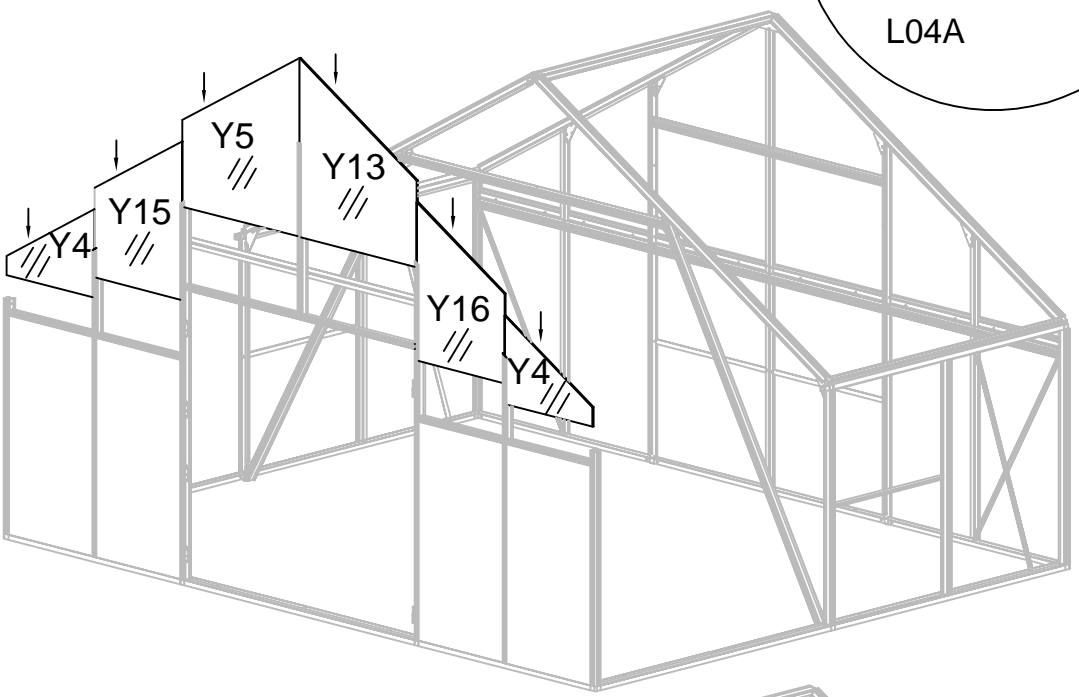
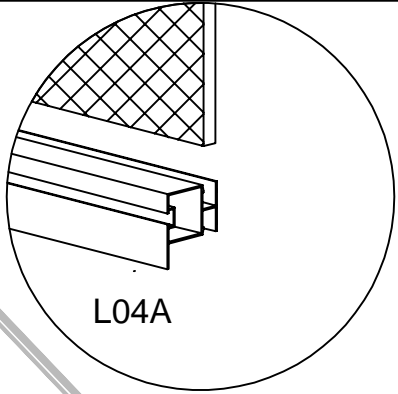

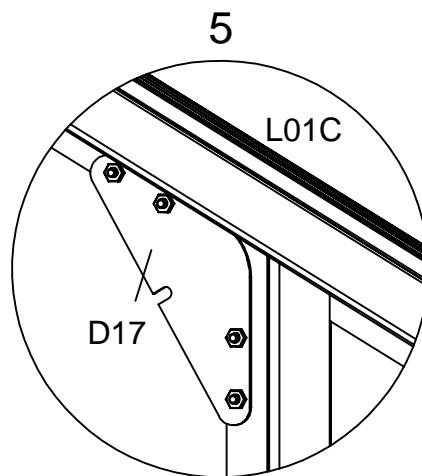
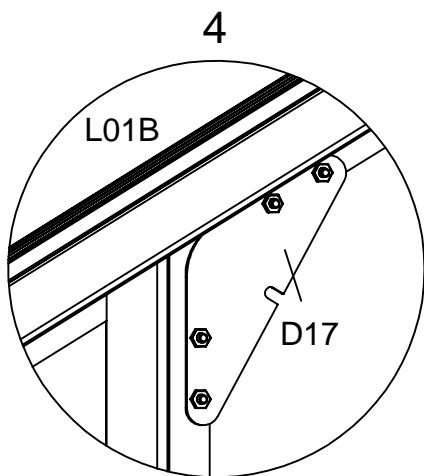
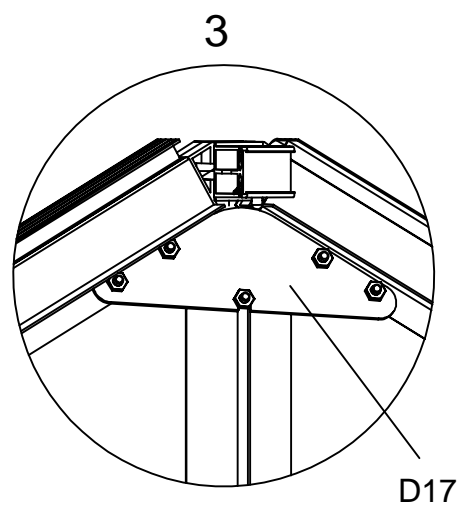
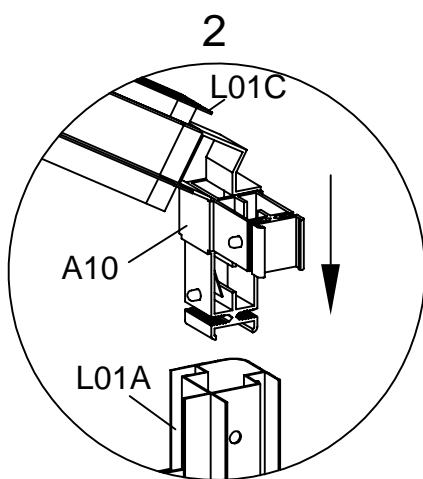
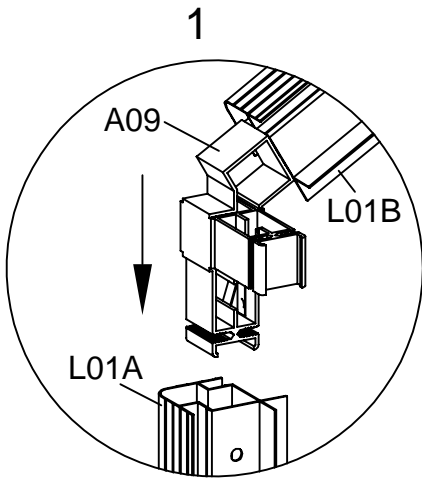
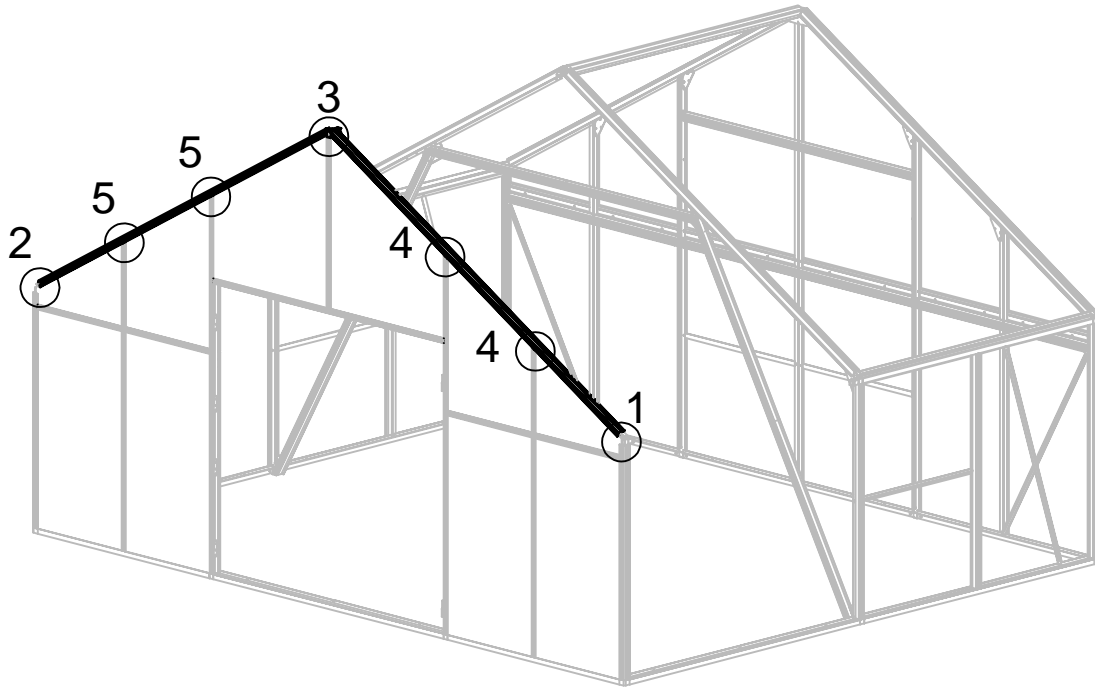

PART	NO.	QTY.
	Y4	2
	Y5	1
	Y13	1
	Y15	1
	Y16	1
	L01B	1
	L01C	1
	A09	1
	A10	1
	A11	1
	D17	3
	S05	12
	M6X12	
	M03	12
	M6	



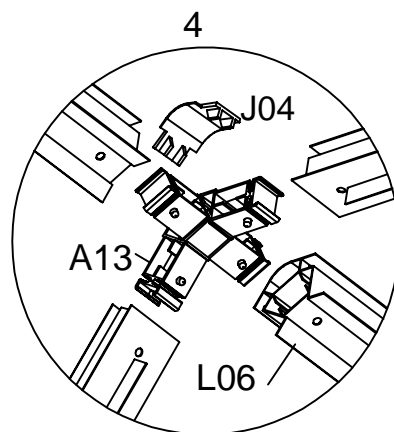
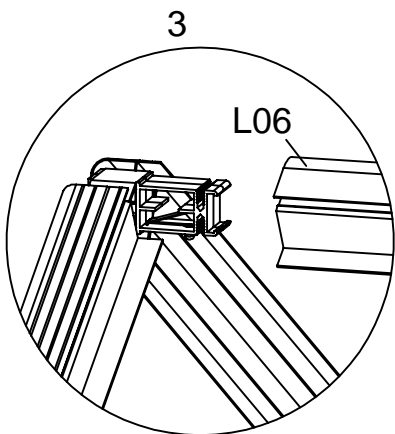
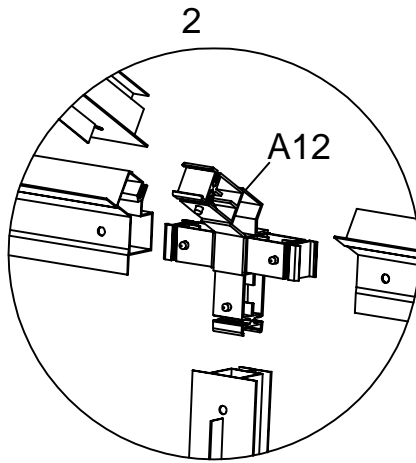
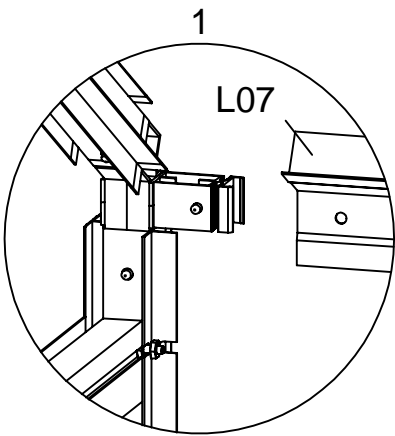
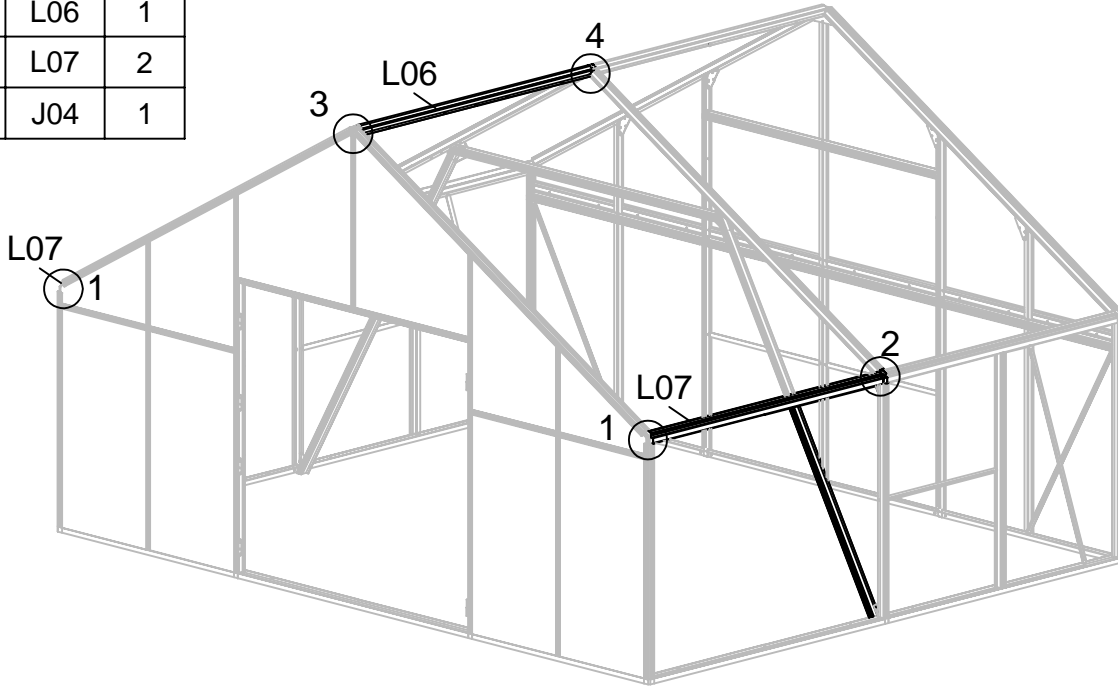





PART	NO.	QTY.
	L06	1
	L07	2
	J04	1

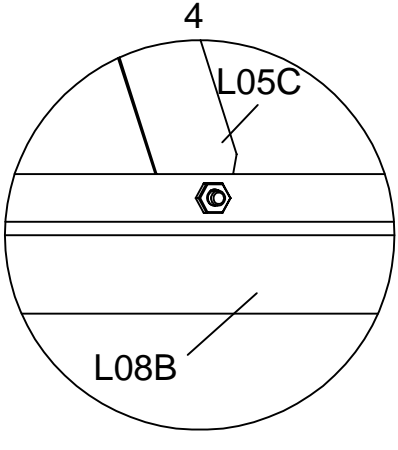
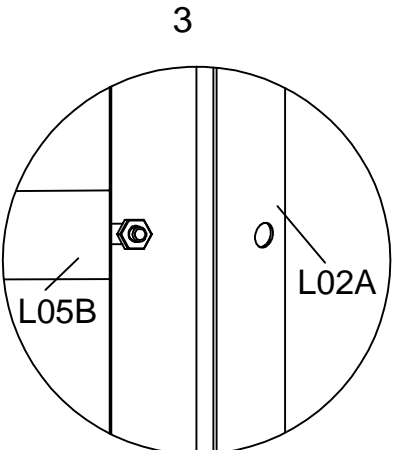
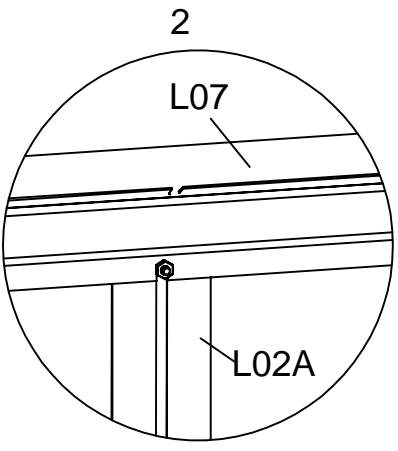
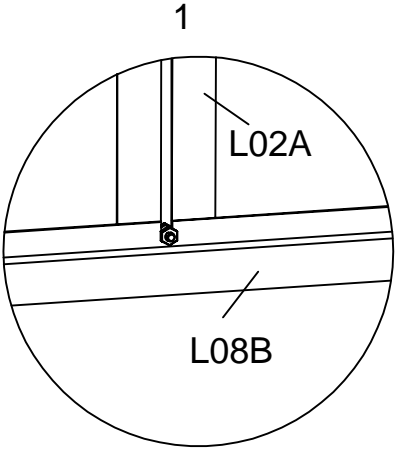
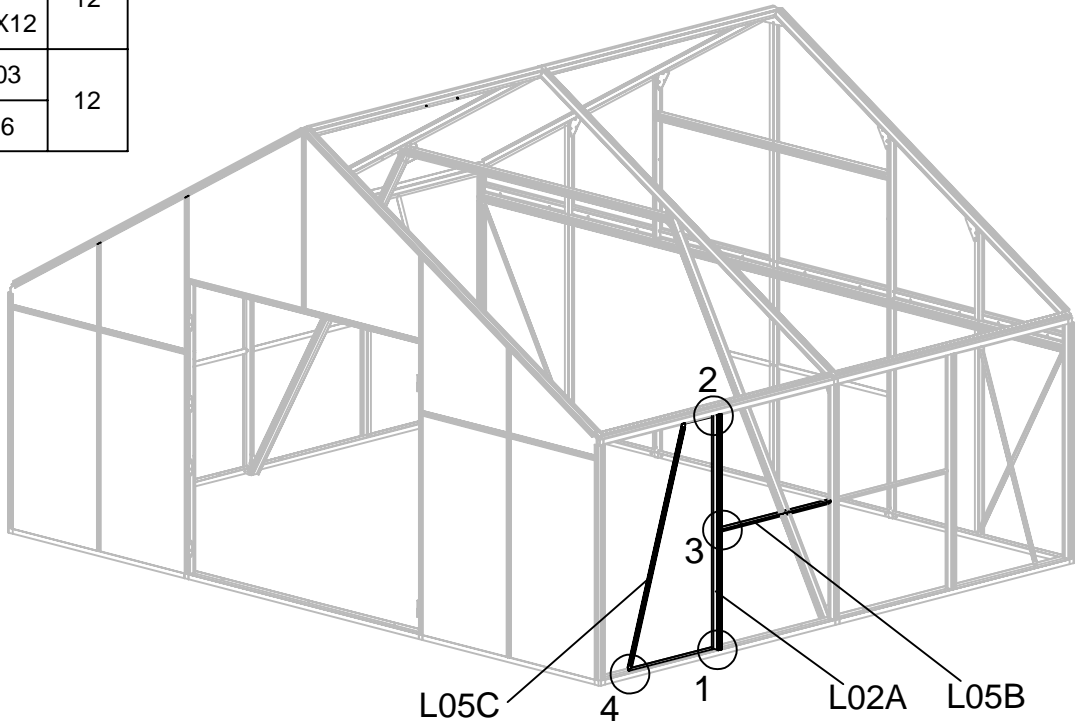





PART	NO.	QTY.
	L02A	2
	L05B	2
	L05C	2
	S05	12
	M6X12	
	M03	12
	M6	

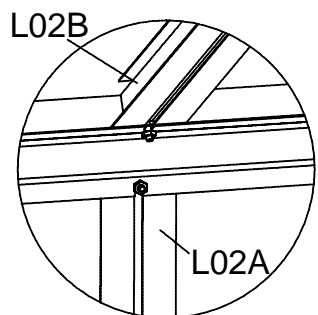
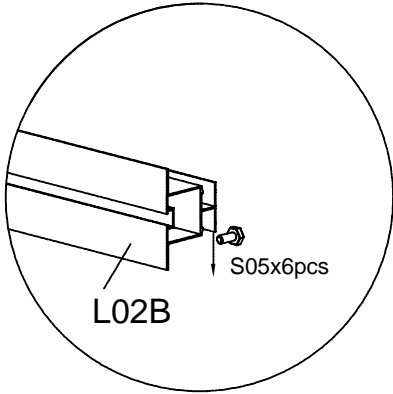
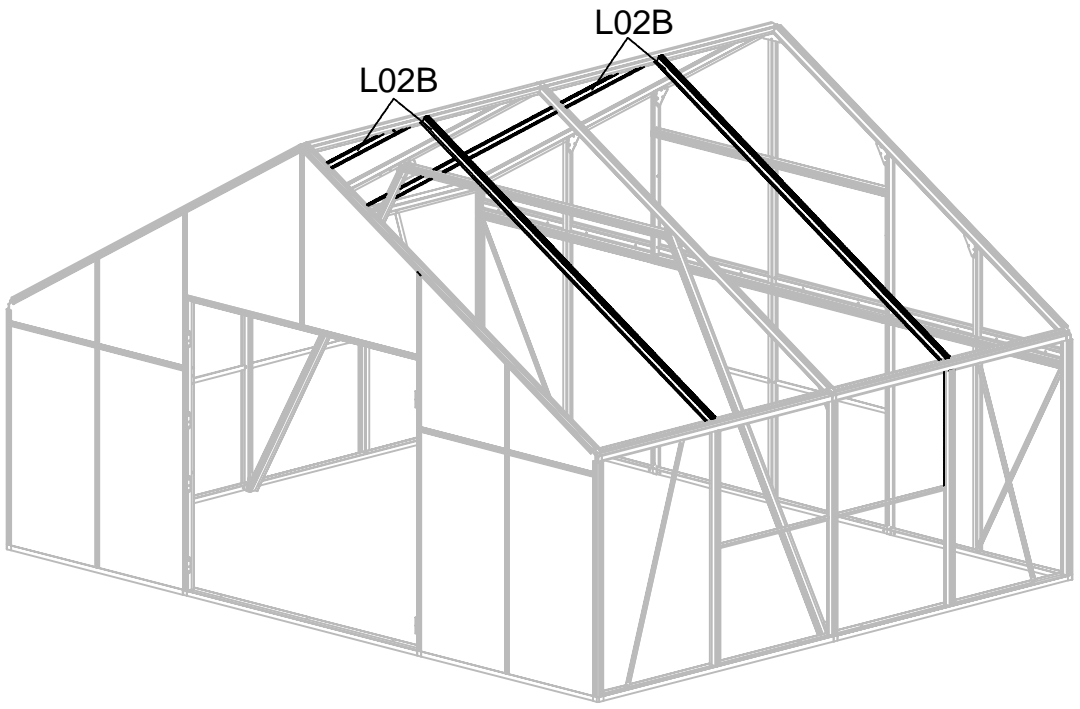





PART	NO.	QTY.
	L02B	4
	S05	24
	M6X12	
	M03	24
	M6	

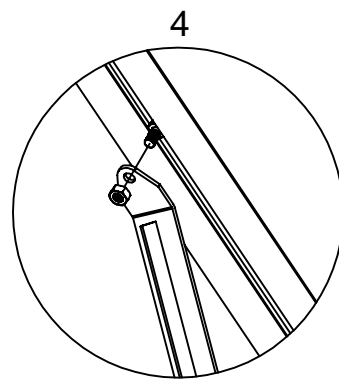
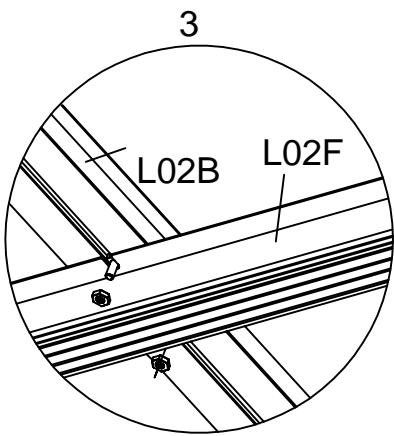
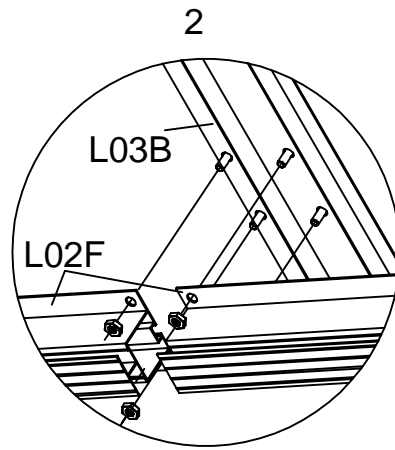
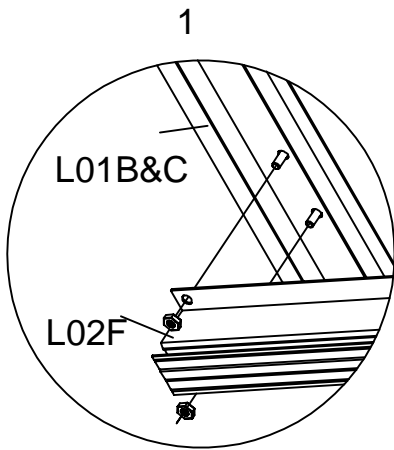
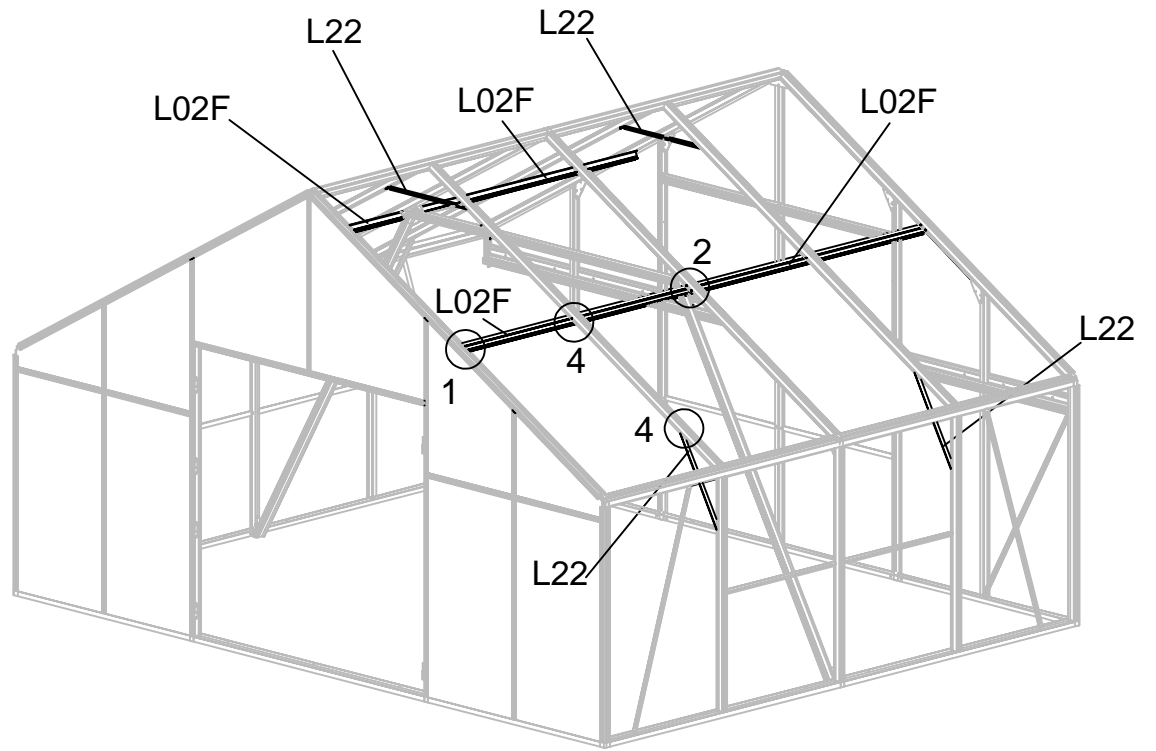

Note: Slide 6xS05 in the channel, which are needed later.









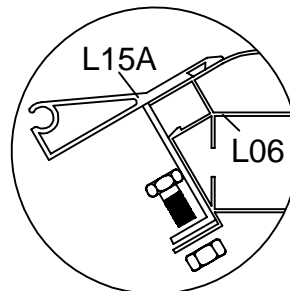
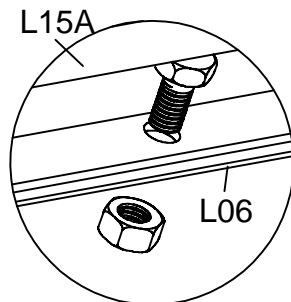
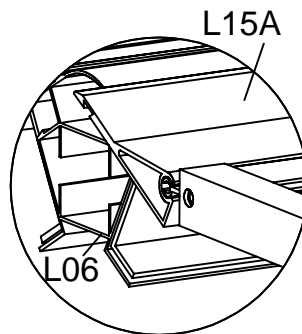
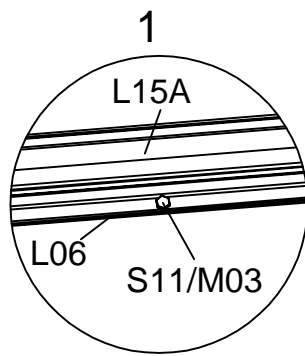
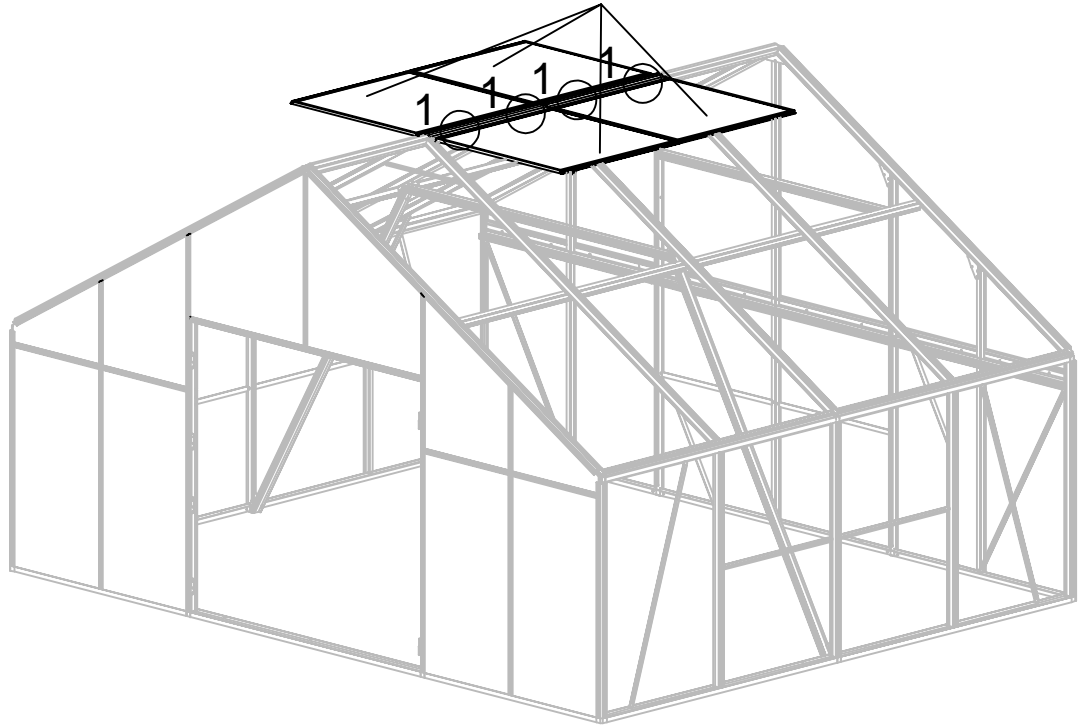

PART	NO.	QTY.
	L02F	4
	L22	6
	S05	20
	M6X12	
	M03	20
	M6	



PART	NO.	QTY.
	Roof Vent	4
	S11	8
	M6X20	
	M03	8
	M6	

Roof Vent Assembly x 4PCS



PART	NO.	QTY.
	Y6	8
	Y7	4
	L04B	4
	L04E	4
	A01	4
	A69	2
	A70	2
	Z04	8
	Ø4X8	
	S05	32
	M6X12	
	M03	32
	M6	

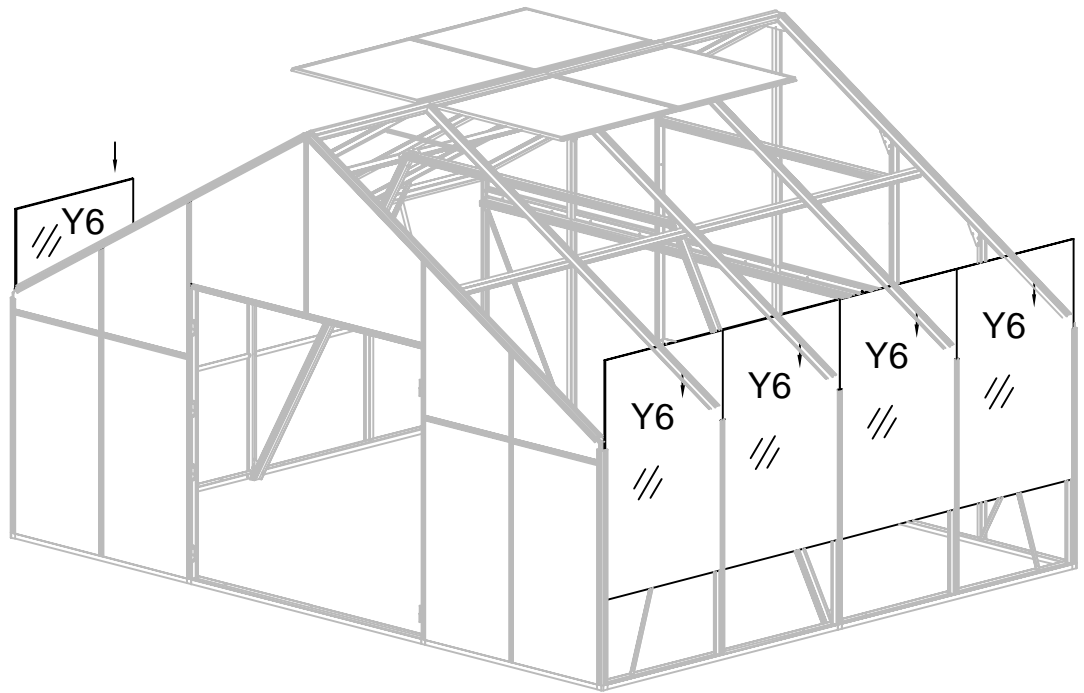

Insert all Y6 into each side of greenhouse.

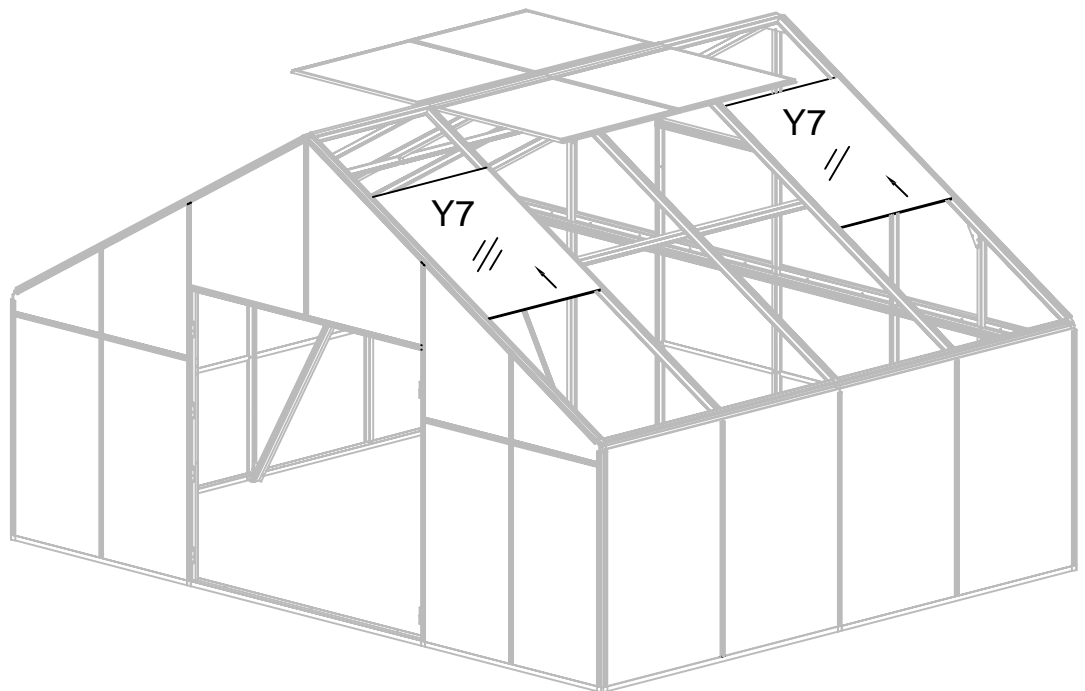

Insert all Y7 into each roof of greenhouse.

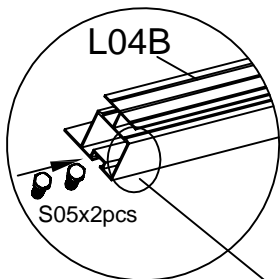
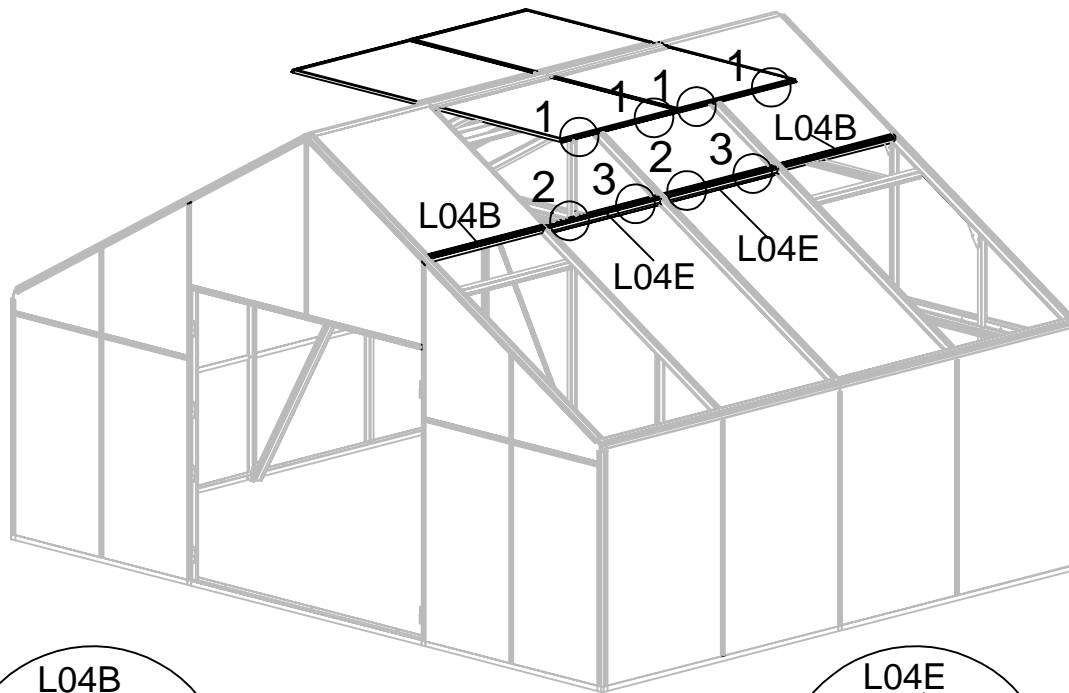



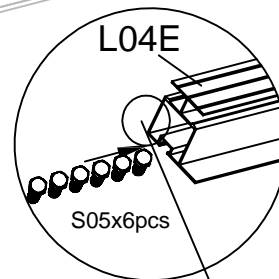

Pay attention to the cut edge of L04B which should be fixed, facing down.

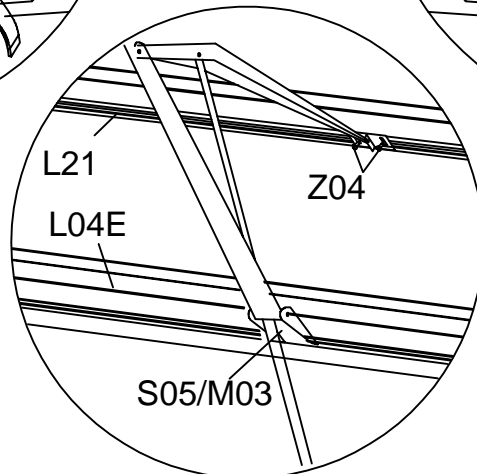
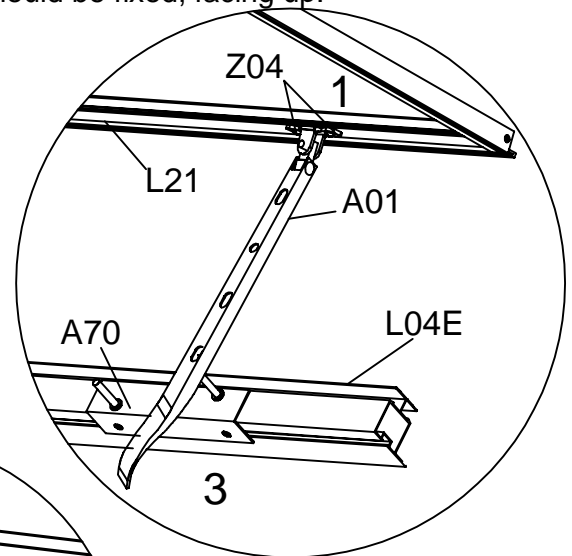
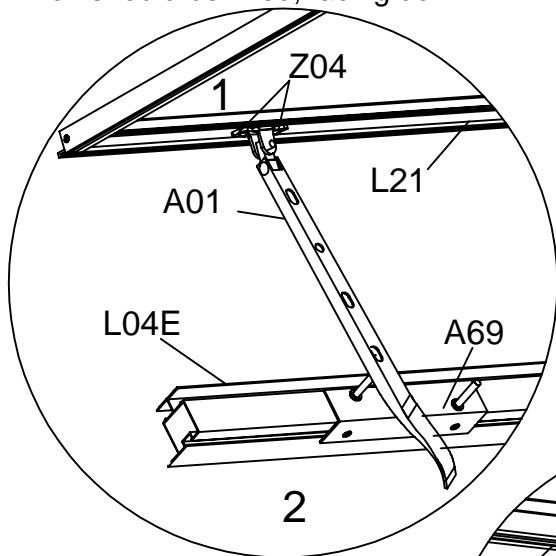

Pay attention to the cut edge of L04E which should be fixed, facing up.







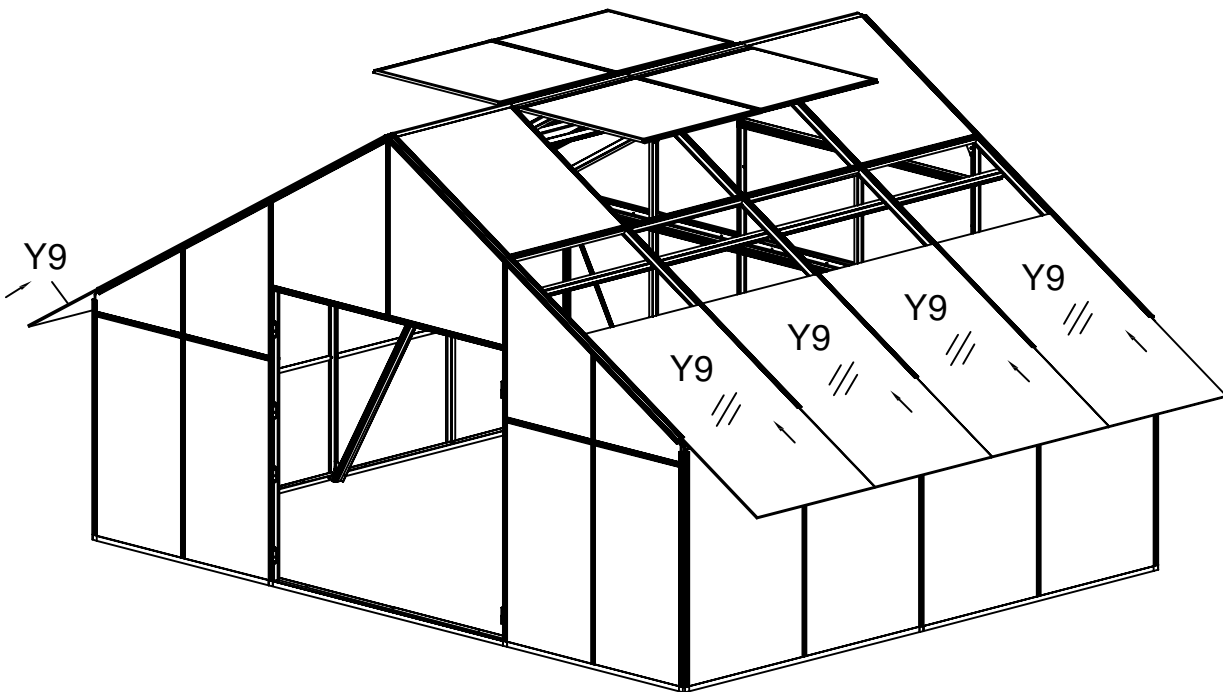
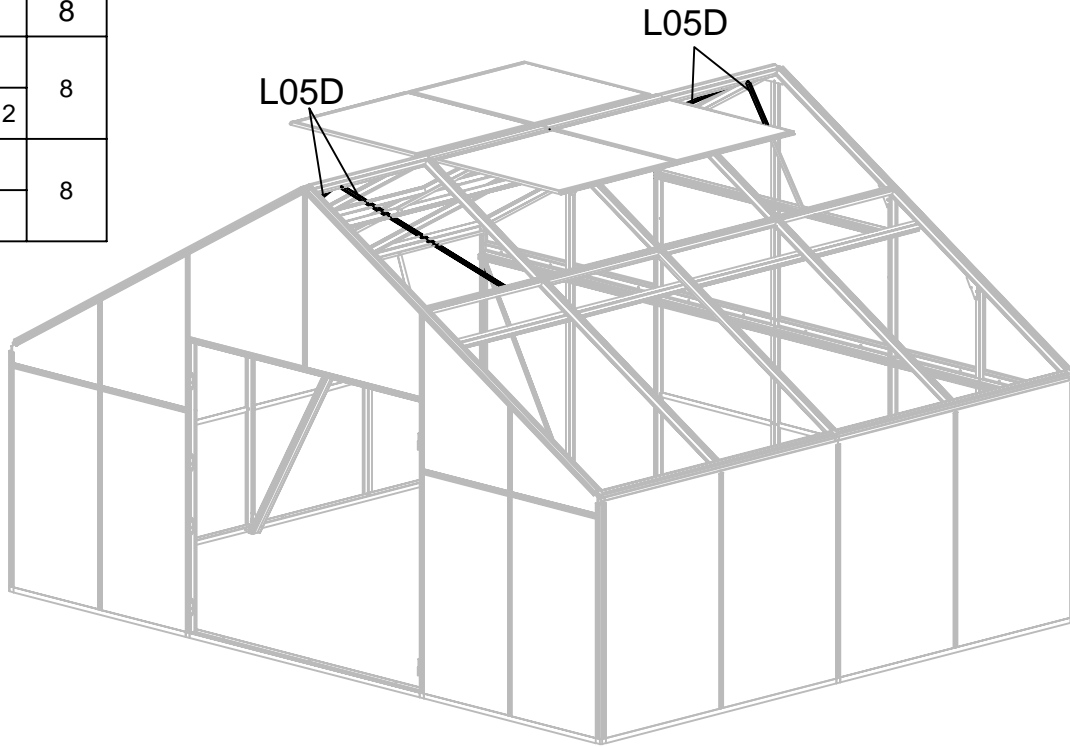









REPEAT the same assembly for another side.

PART	NO.	QTY.
	L05D	4
	Y9	8
	S05	8
	M6X12	
	M03	8
	M6	



Insert all Y9 into each roof of greenhouse.

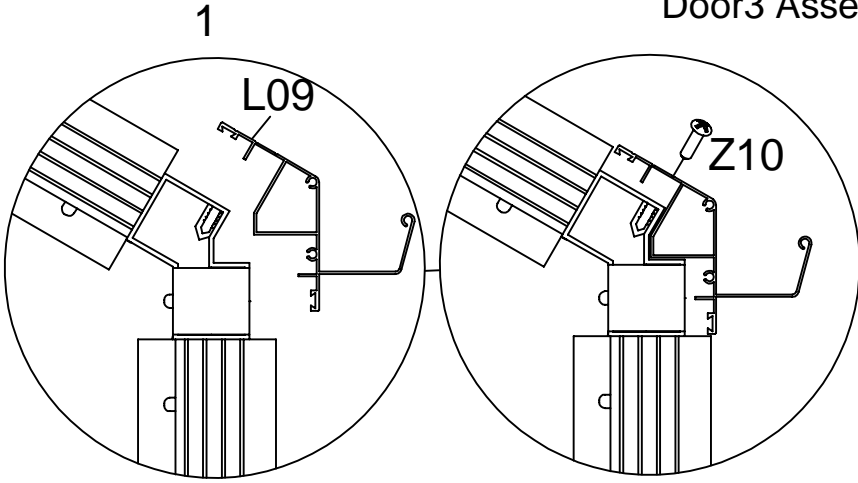
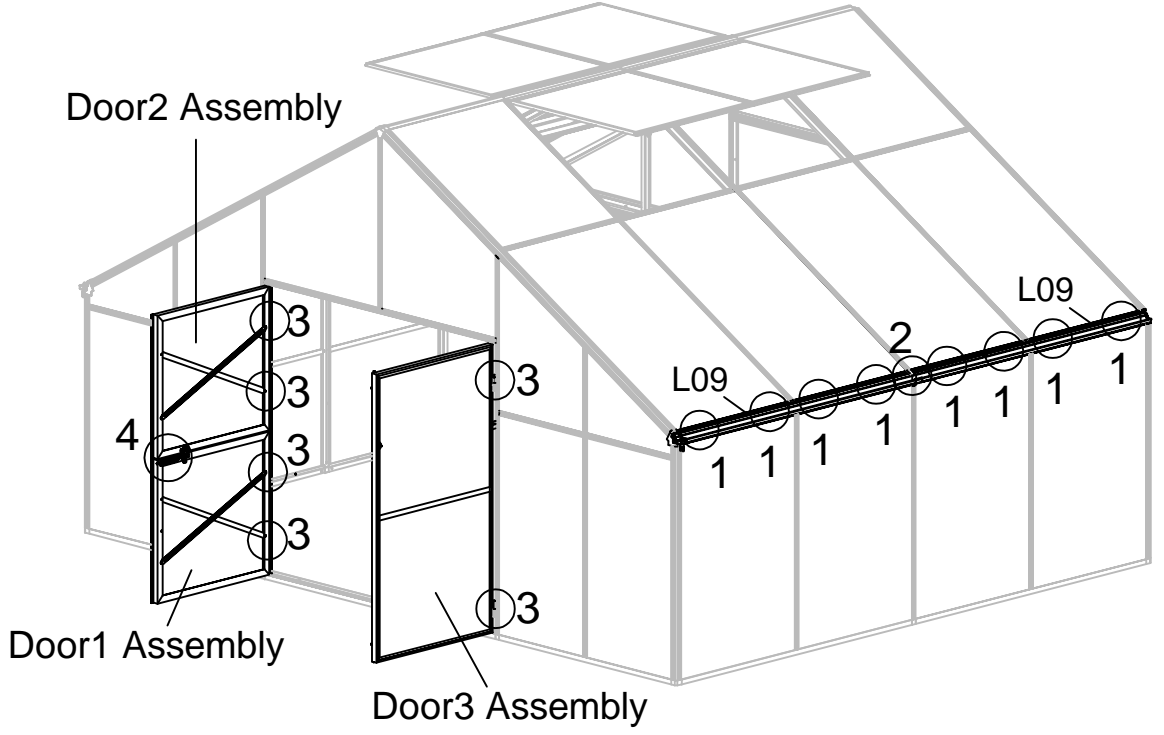

PART	NO.	QTY.
	L09	4
	Door 1	1
	Door 2	1
	Door 3	1
	J07	2
	J02	2
	J06R/L	2/2
	L30	4
	J92	4
	J93	4
	Z10	16
	Ø5X30	
	Z02	12
	Ø4X16D	

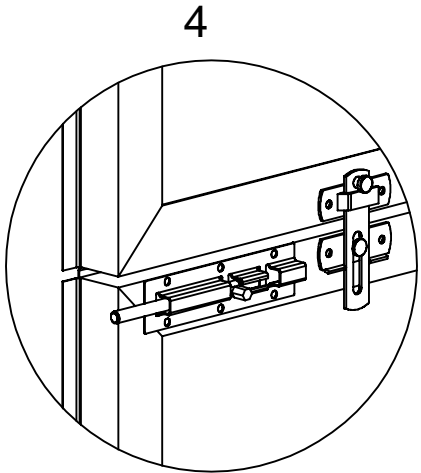
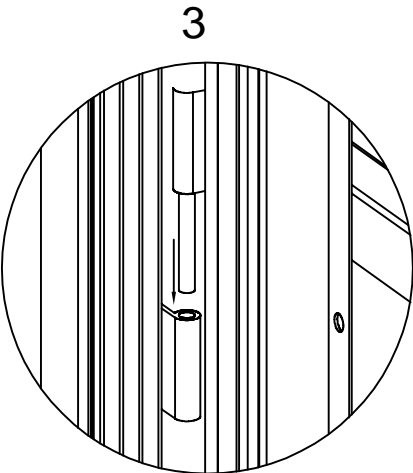
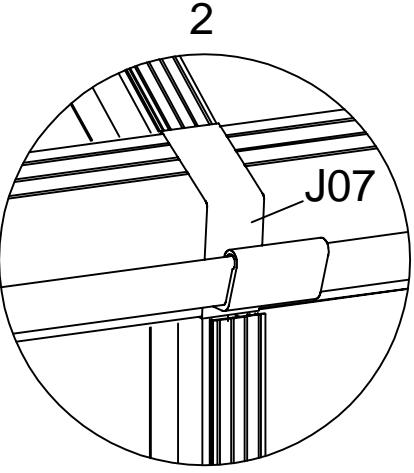

Use L09 to cover the edges of all Y9 after all roof PC panels are fixed in place, then tighten them with Z10.

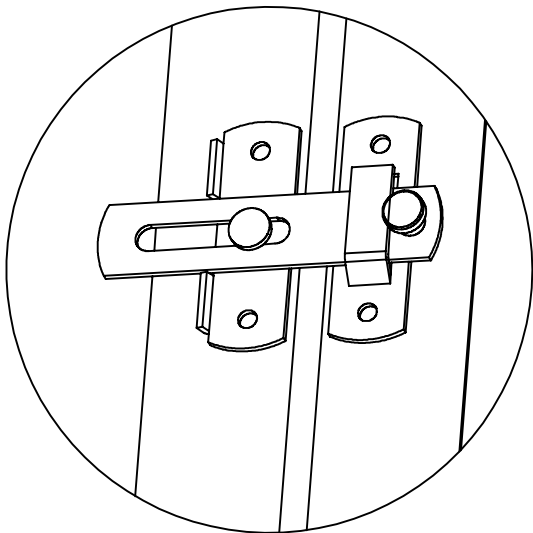
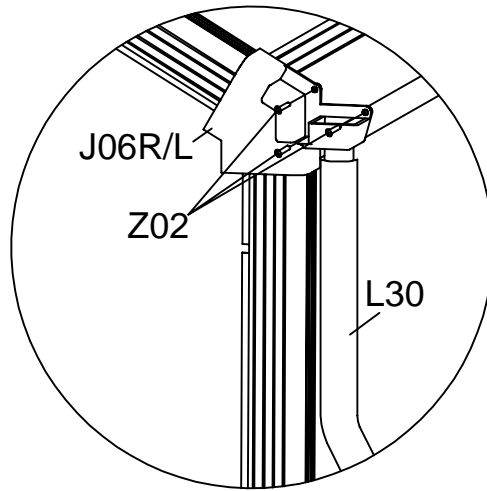
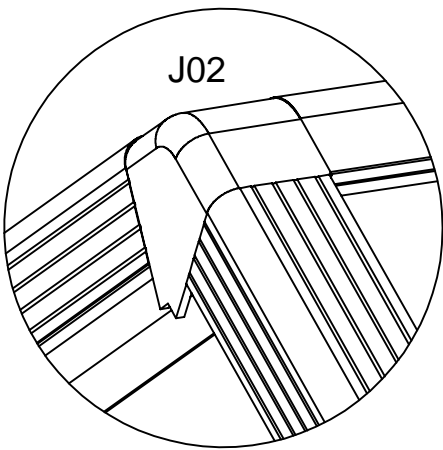
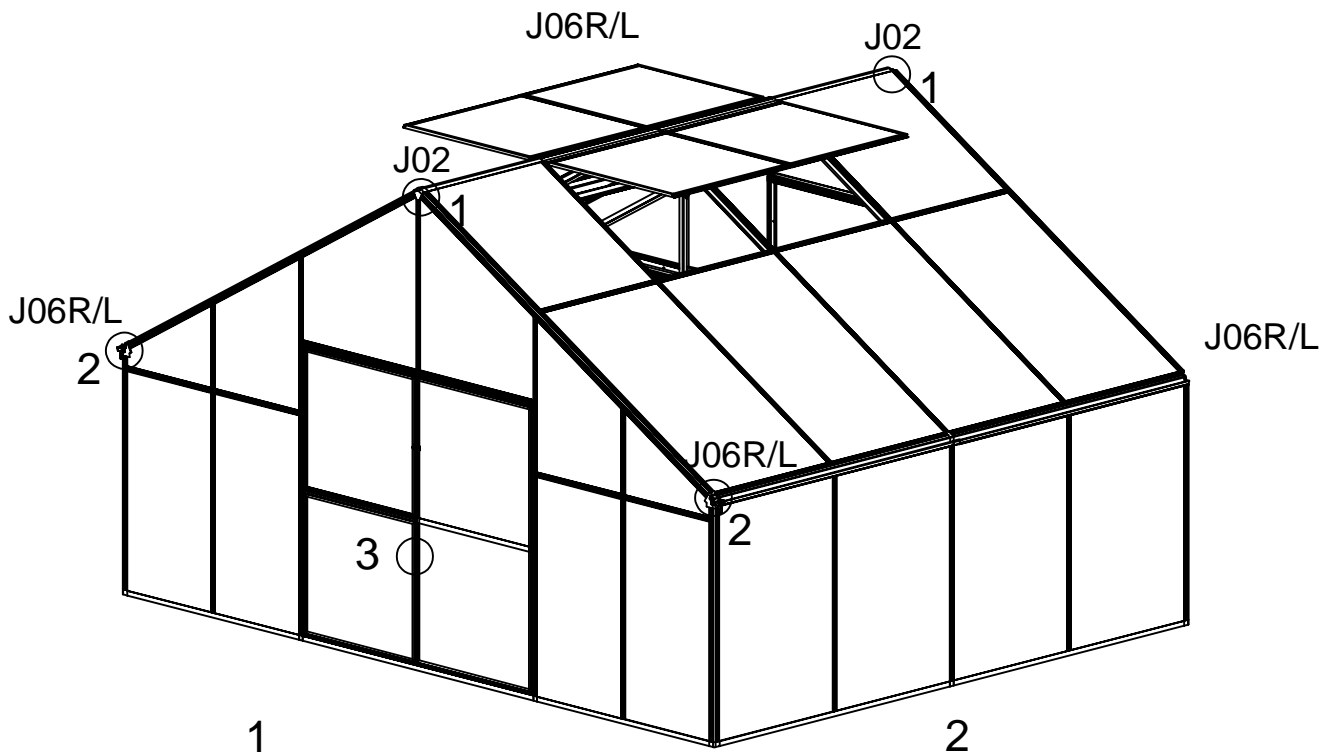



PART	NO.	QTY.
	H10	2
	Z04	4
	Ø4X8	
	Z06	4
	Ø3.2X10	

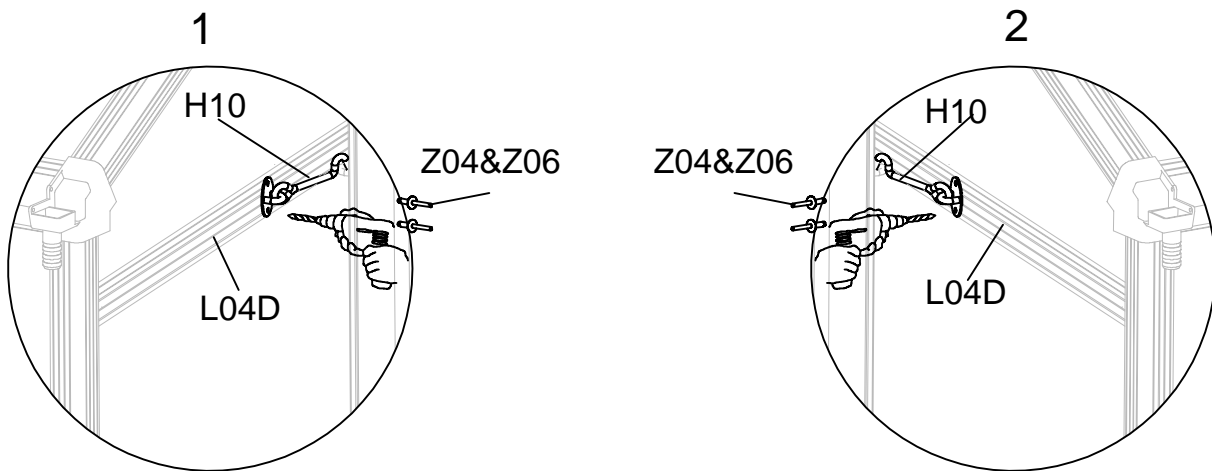
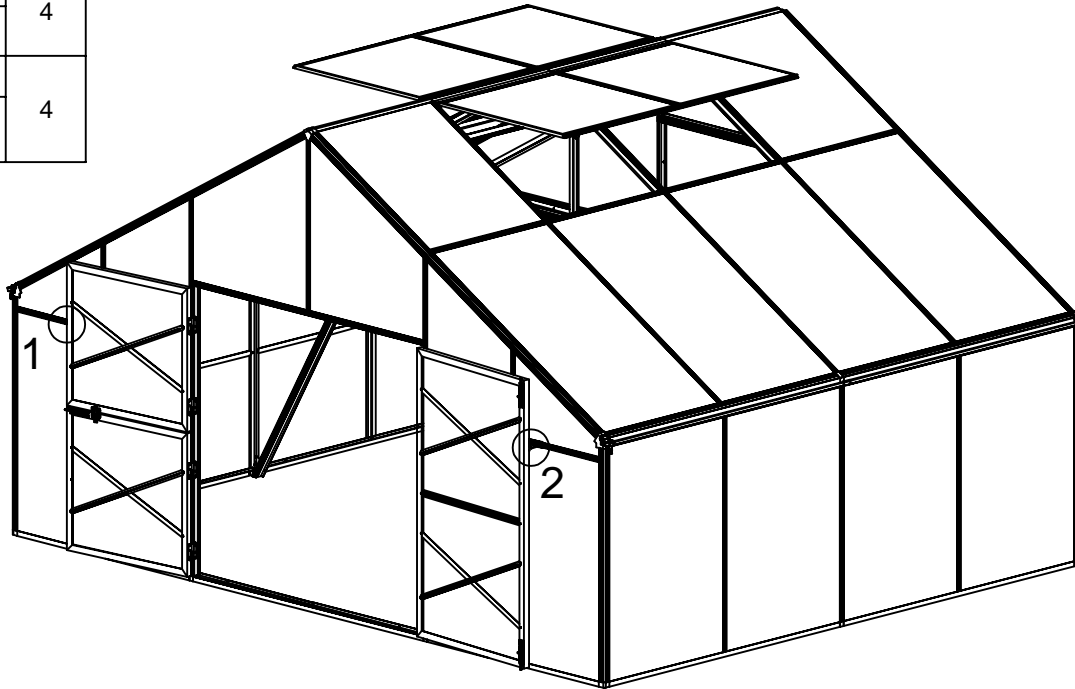

Drill the holes on each L04D as shown, Dia.3.2mm, and secure the hooks H10 with Z04 & Z06, then ensure D17 works with Door1 & 2 & 3 properly when the doors are open.