

GROW MORE Greenhouses

Assembly Instructions

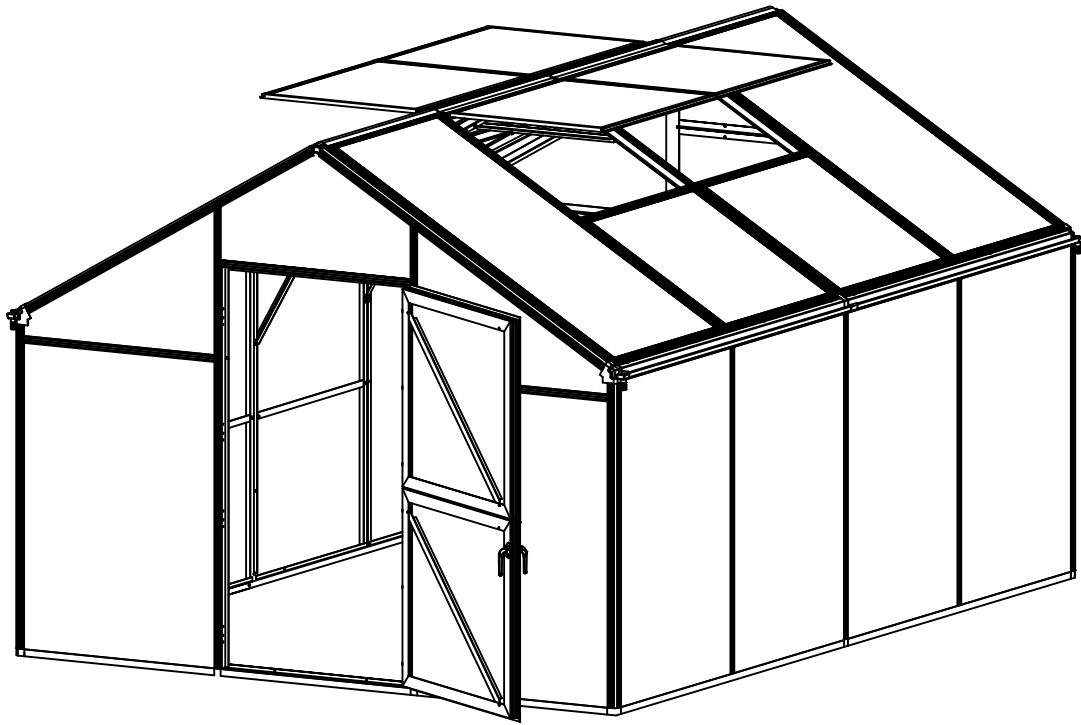

MODEL: GM8

GREENHOUSE SIZE: 10.70' L x 18.37' W x 7.41' H
326cm L x 255cm W x 226cm H

EXTENSION SIZE: 6.56' L x 8.37' W x 7.41' H
160cm L x 255cm W x 226cm H

PLEASE READ INSTRUCTIONS CAREFULLY BEFORE ASSEMBLY

Item No.	Model No.	Packing List				
		AL No.1	AL No.2	AL No.3	PC No.1	PC No.2
2533050	GM8	1CTN <input type="checkbox"/>	1CTN <input type="checkbox"/>		1CTN <input type="checkbox"/>	2CTNS <input type="checkbox"/>
	GM8 ext			1CTN <input type="checkbox"/>		1CTN <input type="checkbox"/>

CONTENTS

1. Assembly Advice	Page 1
2. Product Features	Page 3 - 5
3. Parts List	Page 6 -9
5. Base Assembly	Page 10 - 13
6. Door Assembly	Page 14 - 16
7. Roof Vent Assembly	Page 17
8. Framework & Panel Assembly	Page 18-35

Assembly and Maintenance Advice

1. For safety purposes, we strongly recommend that the product will be assembled by at least two people.
2. Some parts have sharp edges. Please be careful when handling components. Always wear gloves, shoes and safety goggles during assembly.
3. DO NOT climb or stand on the roof, heavy articles should not be leaned against the greenhouse.
4. Keep roof and gutter clean of snow, dirt & leaves. Large amounts of snow on roof can damage the product, making it unsafe to stand below or nearby.
5. When your product needs cleaning, use a mild detergent solution and rinse with cold clean water. Do not use acetone, abrasive cleaners or other special detergents to clean the panels.

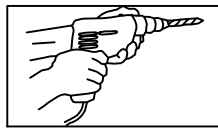
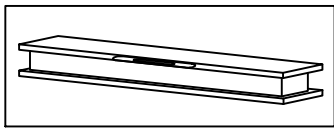
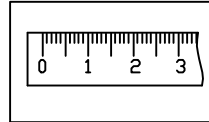
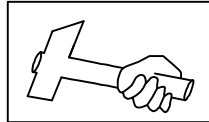
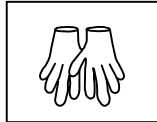
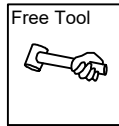
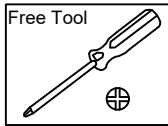
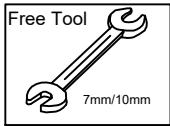

Functions and Features:

1. In comparison to a traditional greenhouse structure, all main profiles are manufactured in a square hollow section design, resulting in a stronger more weather resistant product.

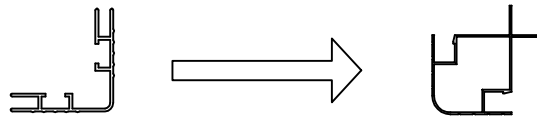

2. Easy and fast assembly.

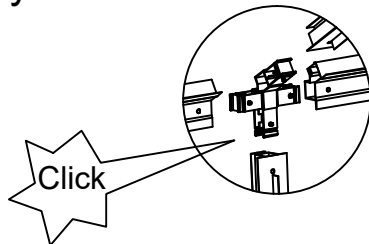

3. The unique design allows the greenhouse to be easily extended at any stage in 2m long sections as detailed in the table of Front Page;

4. The Grange Series greenhouses include gutters and aluminium downpipes to harvest the rainwater. You can also easily connect these to a suitable tank.

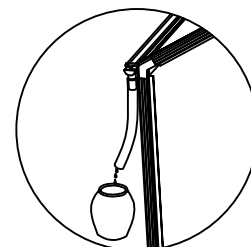

5. A steel base is not required as the aluminium base frame is fixed to the necessary concrete footings with the expansion bolts provided, alternatively you can easily secure it to a timber base with timber screws(not provided).

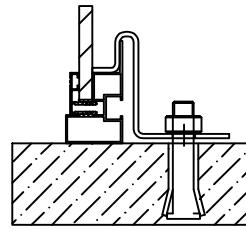

Expansion screw / Concrete ground

6. The Grange Series greenhouses come standard with Manual opening arms. Automatic openers can be purchased seperately and fitted to any window vent. We recommend two automatic vent openers be fitted to each vent in the same positions the standard manual vent arms.

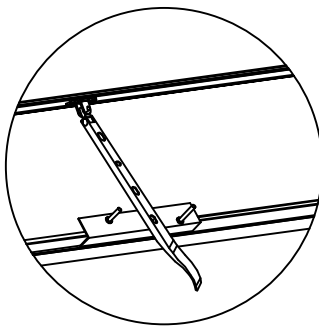

Manual opener

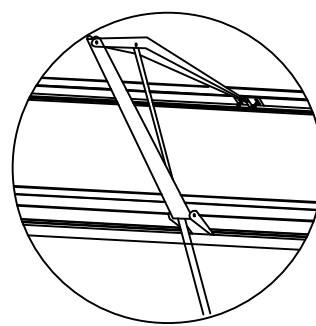

Automatic opener

7. Please ensure the roof vents are not installed into the end roof bays of the greenhouse as this is where you need the bracing.
8. Each Polycarbonate Panel comes with UV protected properties. Please ensure the clear film with the text faces out, toward the sun Remove both films before installation of the panels.

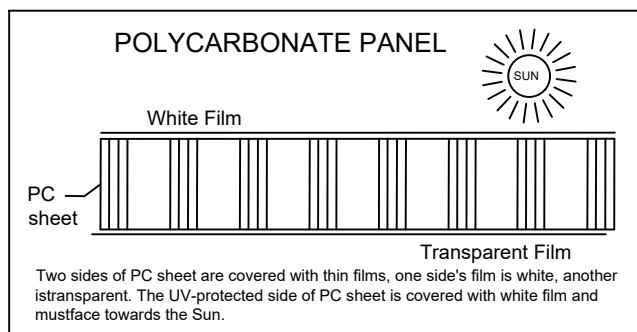

9. Nuts not to be tightened before the end of assembly! Unless otherwise stated, do not tighten the bolts/nuts/screws until the shed is finally erected!

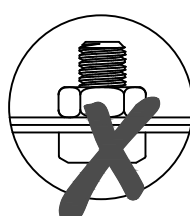
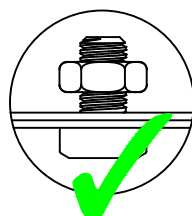



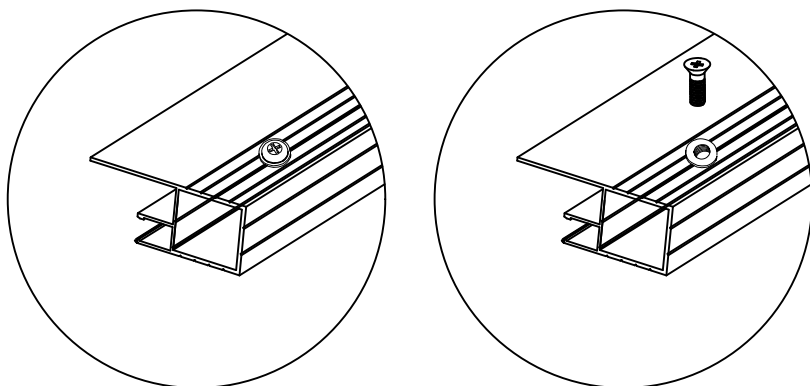



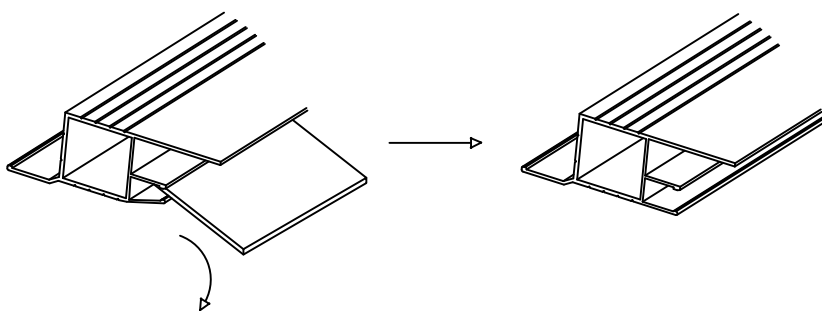











10. S26 and S27 are mostly installed on the profiles. Please remove S26 and S27 before installation.

























11. If the polycarbonate slot is deformed during transport, use a flat wooden or plastic block to straighten it (Avoid sharp objects to prevent damage to the aluminum).





GM8 ALU BOX NO.1

	PART	NO.	QTY.
1		L01A	3
		L01D	1
2		L01B	2
		L01C	2
3		L03C	2
		L03D	2
4		L04A	3
		L04B	4
5		L08A	6
6		L18A	2
7		L18B	1
		L16B	1
8		L16C	1
		L16D	1
9		L16E	1
		L16F	1
10		L05G	2
		L05A	4
11		L30	4



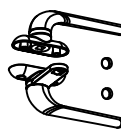



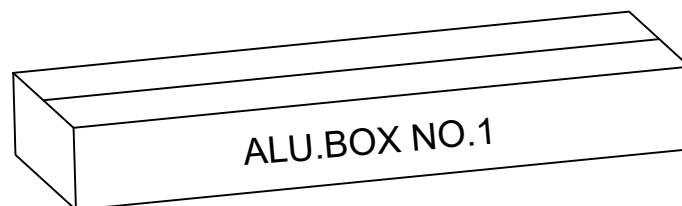
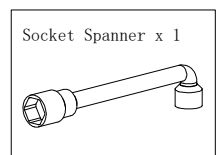
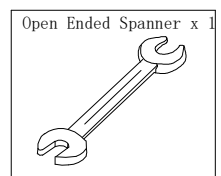
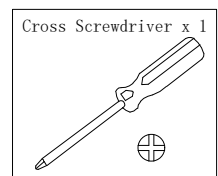











	PART	NO.	QTY.
		A52	2
		A53	2
		A54	4
		A09	2
		A10	2
		A11	2
		A89-1	1
		A89-2	1
		D07	5
		D77	8
		H63	6
		S05 M6X12	50
		M03 M6	50
		S08 M8X60	5
		Z02 Ø4X16D	12
		Z08 M4.2X16	32
		Z17 M5X12	12















	PART	NO.	QTY.
		J01	4
		J03	4
		J02	2
		J06R/L	2/2
		J93	4
		J92	4



PART	NO	QTY
	H152	1
	D47-1	1
	S77 M4X50	2



GM8 ALU BOX NO.2







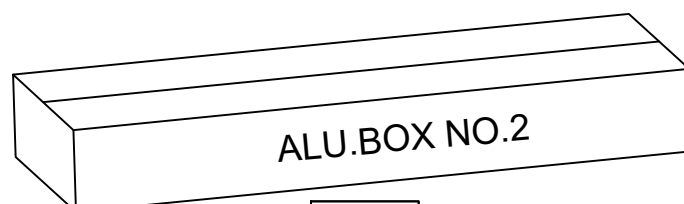











	PART	NO.	QTY.
1		L02A	4
2		L02B	4
3		L05B	4
		L05C	4
		L05D	4
4		L06	2
5		L07	4
6		L08B	4
7		L09	4
8		L15A	4
9		L19	8
		L20	4
		L21	4
10		L04E	4
11		L22	6
12		L03A	2
13		L03B	2
14		L05E	2
		L05F	4















	PART	NO.	QTY.
		A54	2
		A12	2
		A13	1
		D07	8
		A01	8
		A69	4
		A70	4
		S05 M6X12	82
		S08 M8X60	8
		S11 M6X20	8
		M03 M6	90
		Z02 Ø4X16D	24
		Z04 Ø4X8	16
		Z10 Ø5X30	16



	PART	NO.	QTY.
		J03	2
		J04	1
		J07	2



GM8 2EXT. ALU BOX NO.3

	PART	NO.	QTY.
1		L02A	2
2		L02B	2
3		L05B	2
		L05C	2
		L05D	2
4		L06	1
5		L07	2
6		L08B	2
7		L09	2
8		L15A	2
9		L19	4
		L20	2
		L21	2
10		L04E	2
11		L22	3
12		L03A	2
13		L03B	2
14		L05E	2
		L05F	4

	PART	NO.	QTY.
		A54	2
		A12	2
		A13	1
		D07	4
		A01	4
		A69	2
		A70	2
		S05 M6X12	44
		S08 M8X60	4
		S11 M6X20	4
		M03 M6	48
		Z02 Ø4X16D	12
		Z04 Ø4X8	8
		Z10 Ø5X30	8

	PART	NO.	QTY.
		J03	2
		J04	1
		J07	2

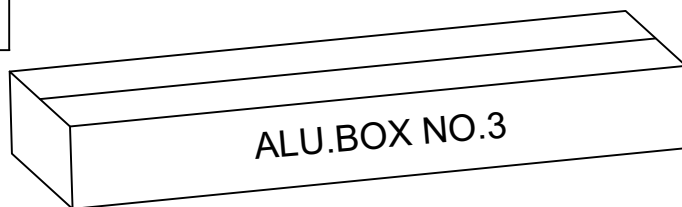





PC Box No. 1





Door Assembly

PART	NO.	QTY.
	Y11	2

Front Assembly

PART	NO.	QTY.
	Y1	1
	Y2	2
	Y4	1
	Y5	1

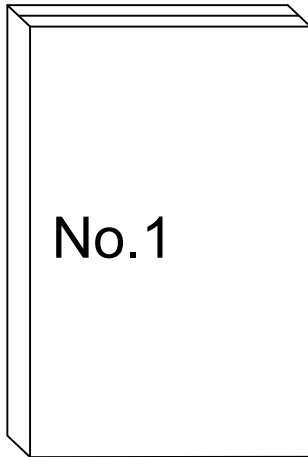

Back Assembly

PART	NO.	QTY.
	Y1	1
	Y2	2
	Y3	2
	Y4	1
	Y5	1



PC Box No. 2

1X2 Sections Assembly

PART	NO.	QTY.
	Y6	4
	Y7	2
	Y9	2
	Y10	2

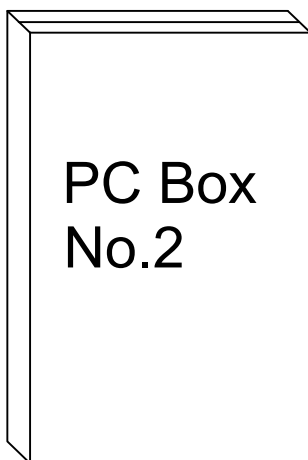

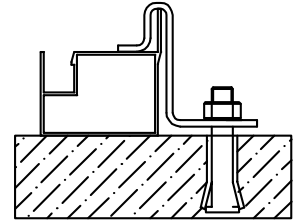
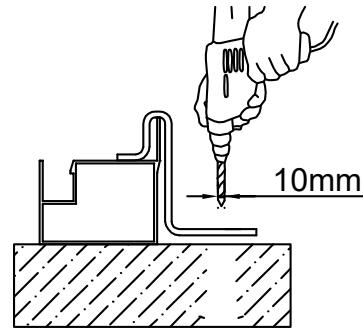
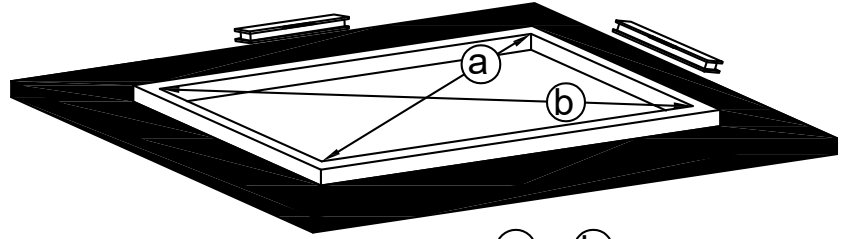
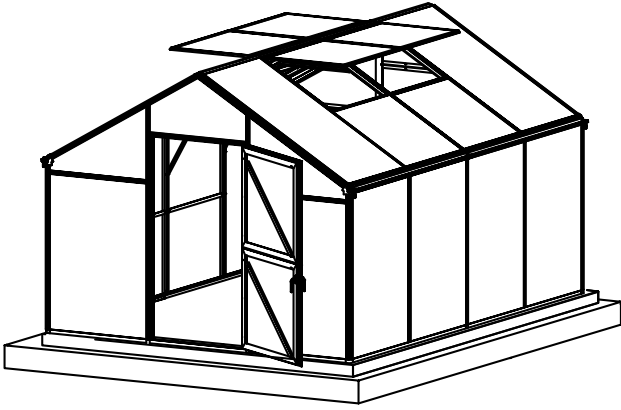

Expansion screw / Concrete ground

* It is crucial the a + b dimensions are the same to ensure the base is square.

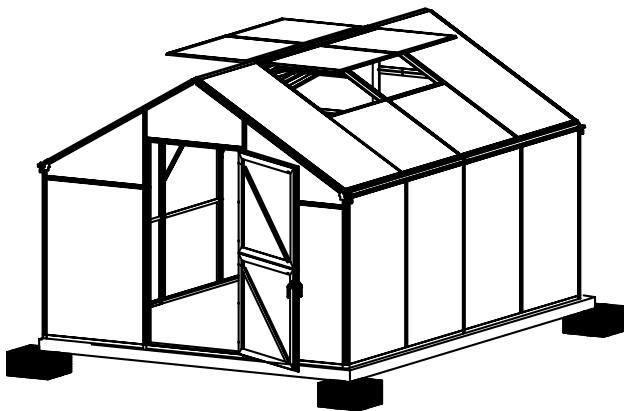
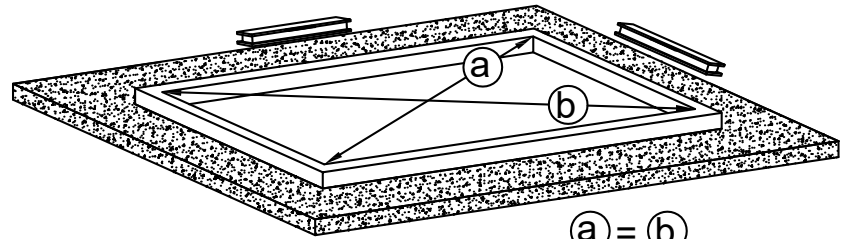
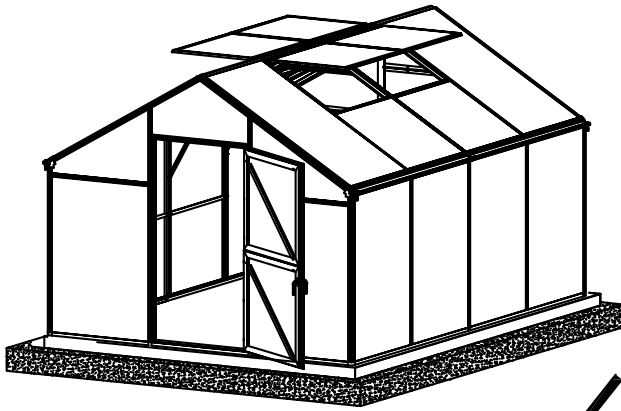

Support at the corners only is not adequate.

GM8

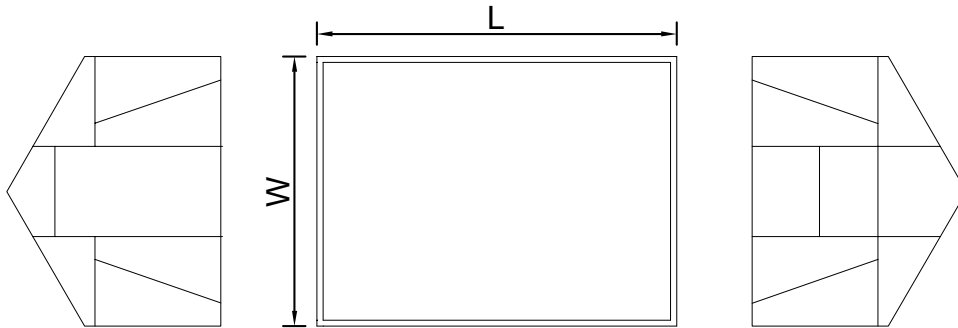
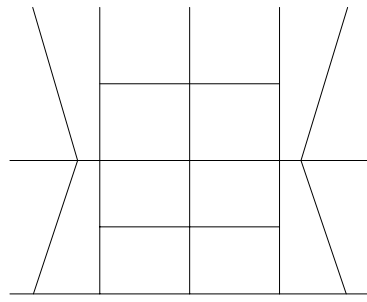

Front Assembly

Back Assembly

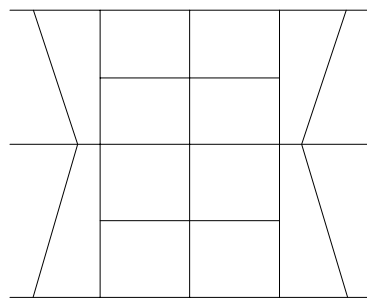

1 2 3 4
4 Section Assembly

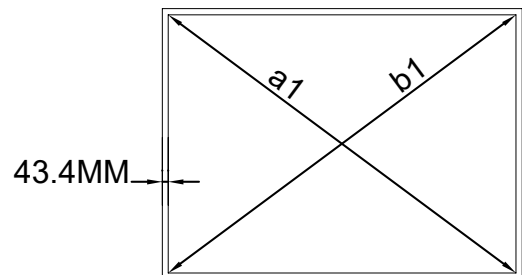



Dim/Model	GM8	GM8+Ext(1)	GM8+Ext(2)	GM8+Ext(3)	GM8+Ext(4)	etc.
W (mm)	2458.8	2458.8	2458.8	2458.8	2458.8	
L (mm)	3259.8	4861.8	6463.8	8065.8	9667.8	
a=b(mm)	4083.1	5448.2	6915.7	8432.3	9975.6	
a1=b1(mm)	3961.6	5331.7	6803.9	8324.1	9870.3	

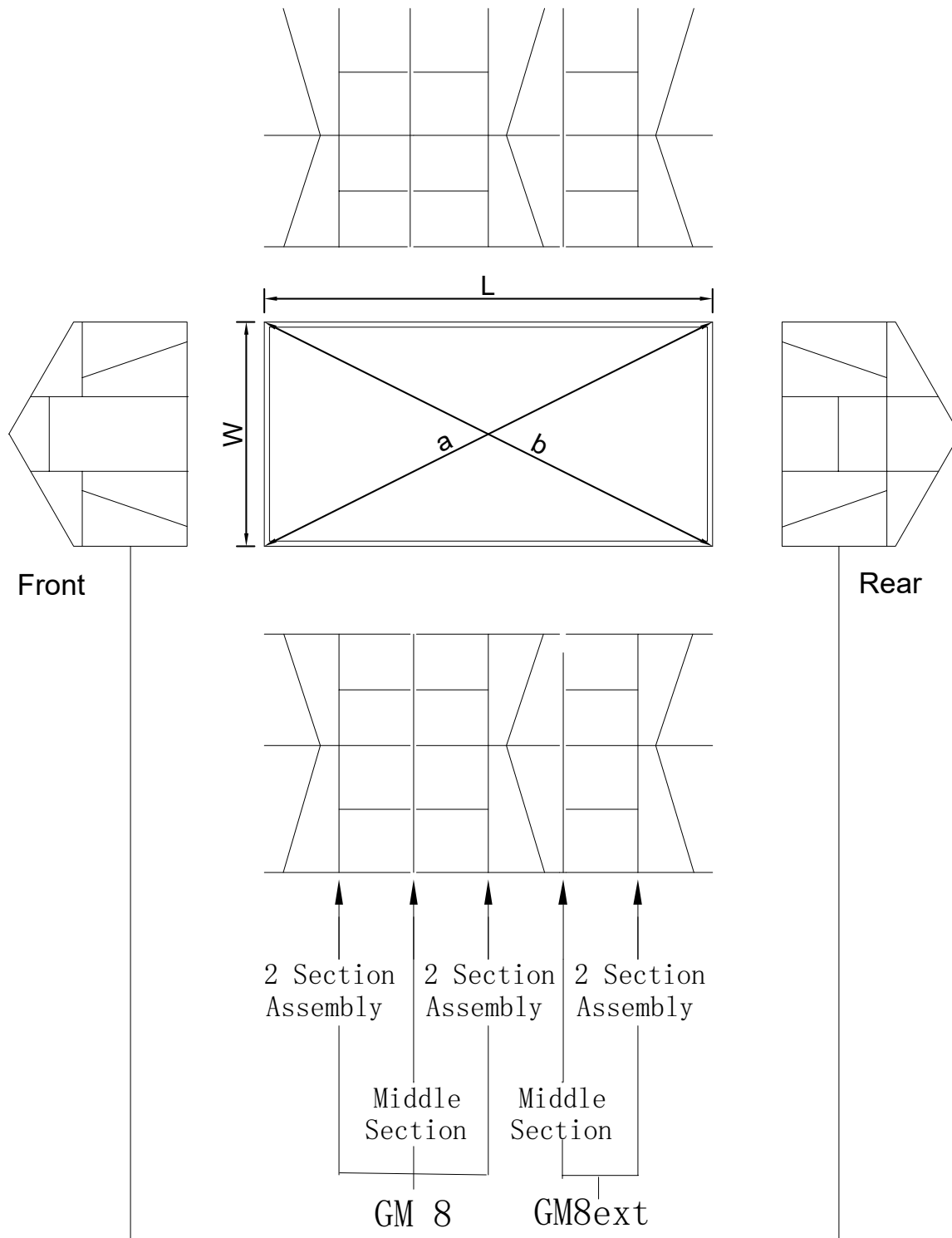

- * W= Outer Width of Base Profiles
- * L= Outer Length of Base Profiles
- * a=b= Outer Diagonal of Base Profiles
- * a1=b1= Inner Diagonal of Base Profiles

GM8 + Ext(1)



* The basic model, GM10, can be easily extended by adding a '2 Section Assembly' each time for a longer size

PART	NO	QTY
	D07	13
	S08 M8X60	13

PART	NO	QTY
	D07	4
	S08 M8X60	4

GM8

GM8 2EXT

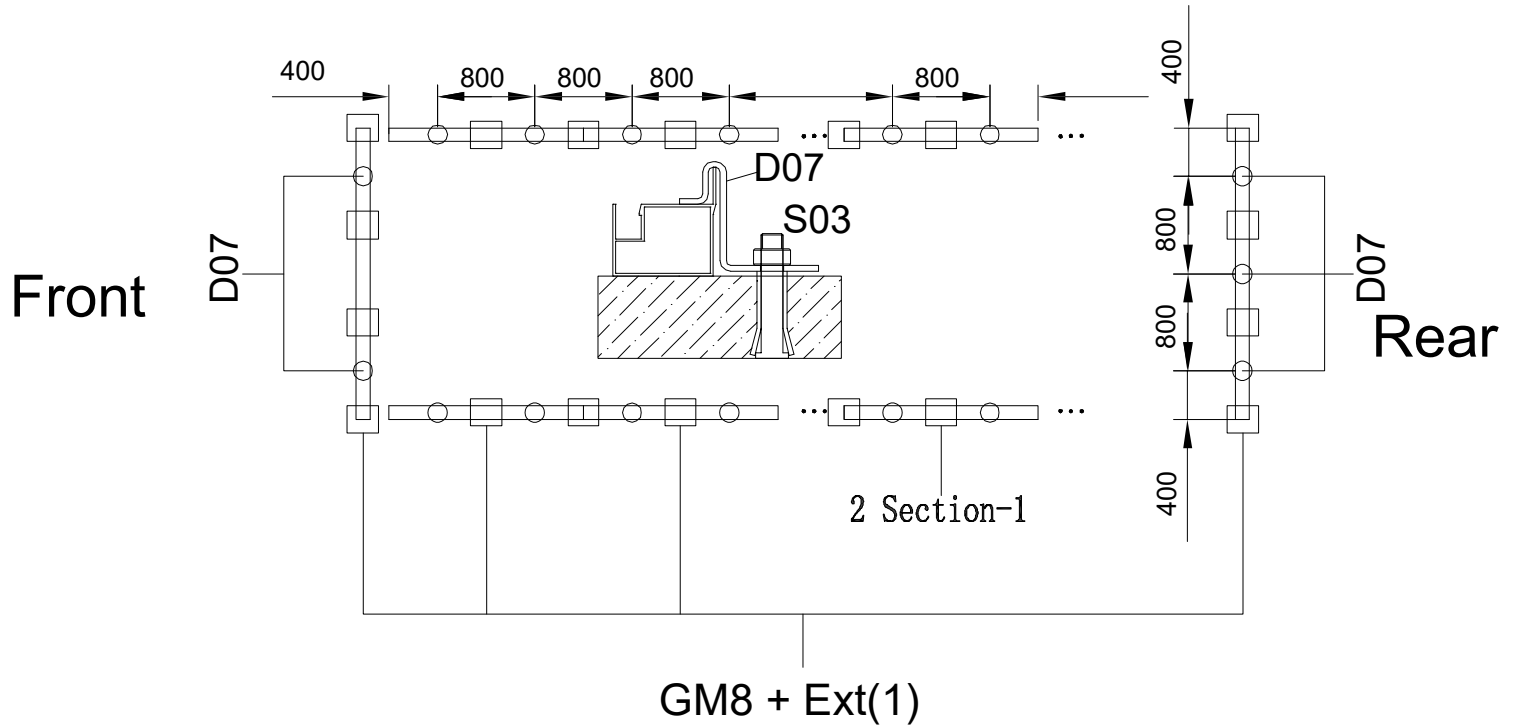

* This shows a layout for D07's positions where it is placed in the middle of PC panel for each section.

* All measurements in above diagram are in mm.

PART	NO	QTY
	L18A	2
	L18B	1
	L16B	1
	L16C	1
	L16D	1
	L16E	1
	L16F	1
	L05G	2
	D77	8
	Z08 M4.2X16	32
	S05 M6X12	4
	M03 M6	4
	Y11	2
	A89-2	1
	S89 M3X12	2

Door-R1 Assembly

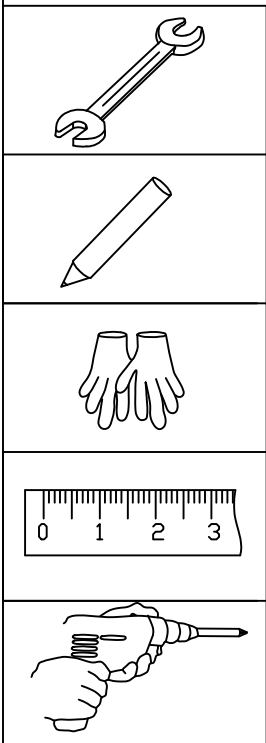
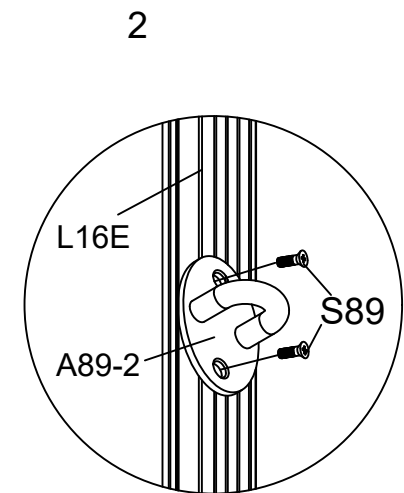
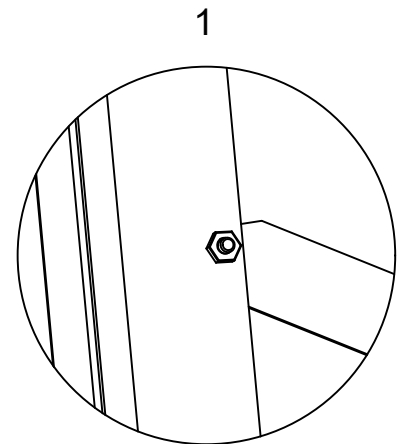
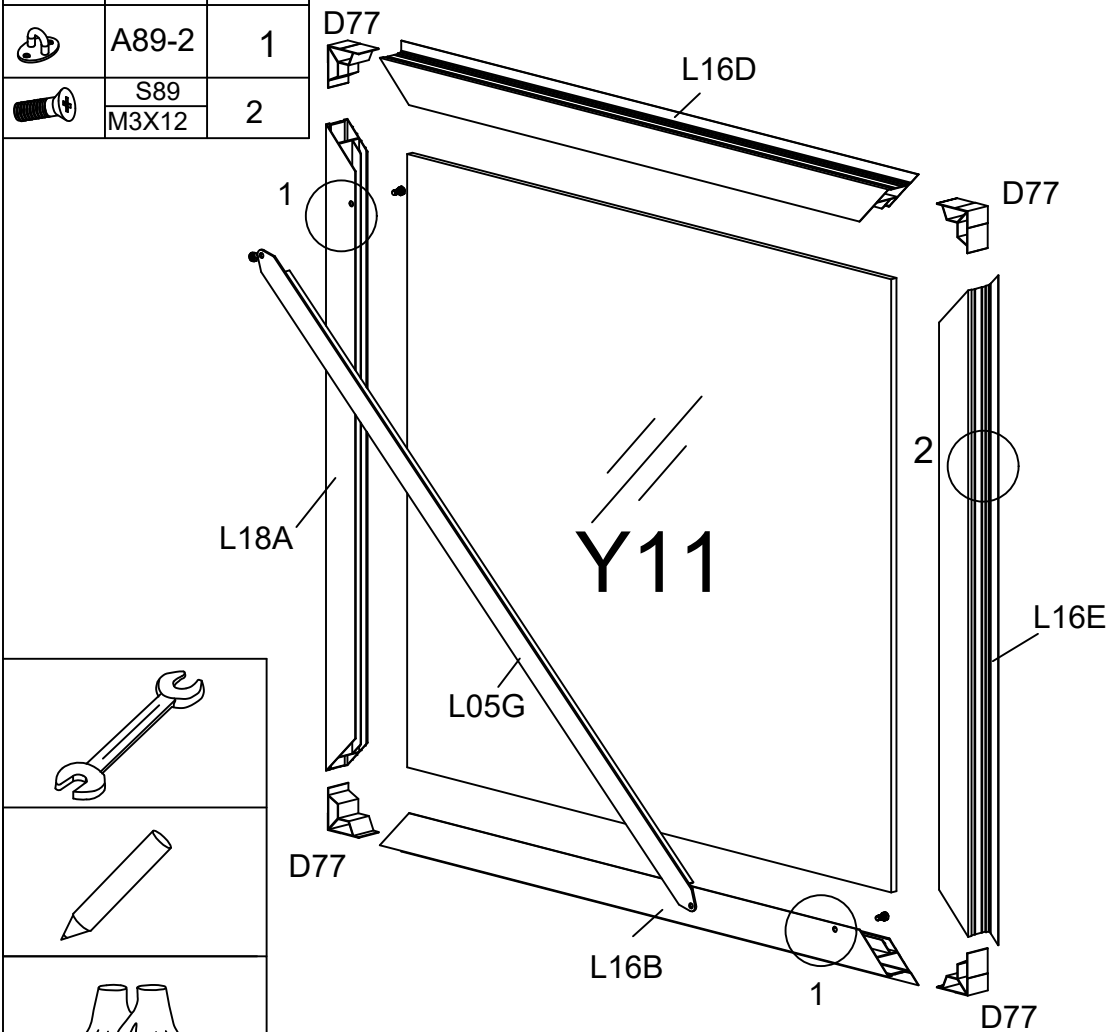
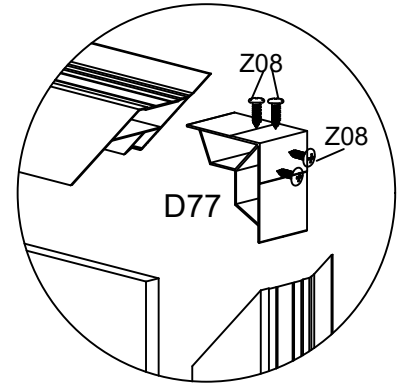
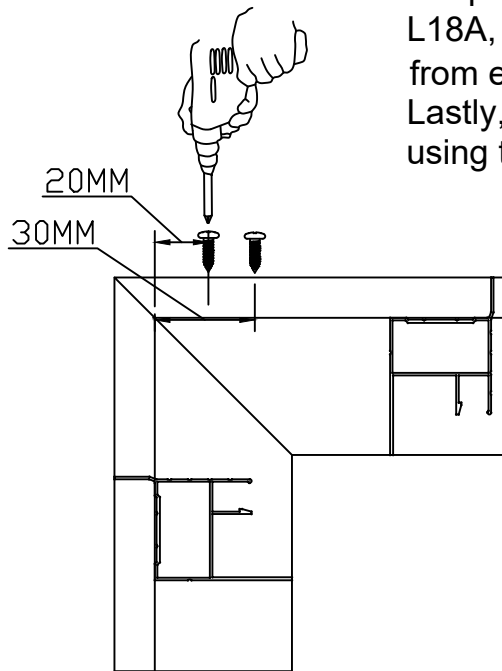

Insert Connector D77 into each end of the profiles L16B & L16D & L16E & L18A, and then mark the distance from each end about 20/30MM. Lastly, secure them with screws Z08 using the powered screw-driver.

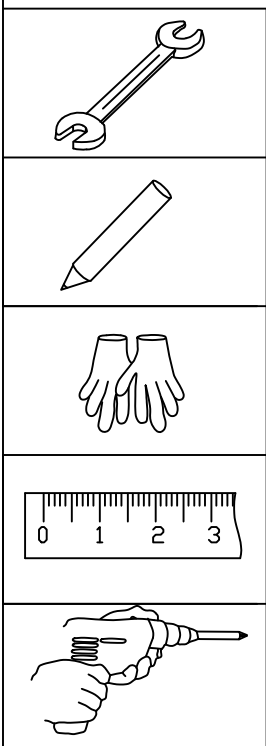
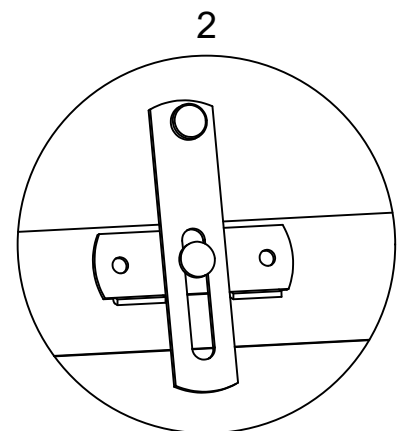
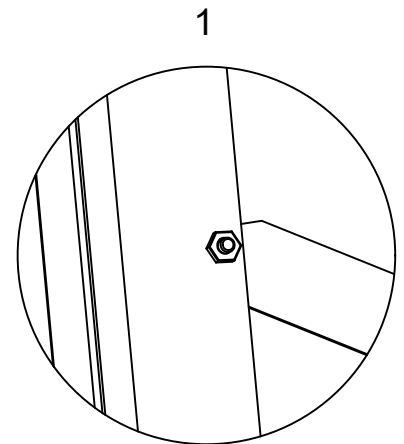
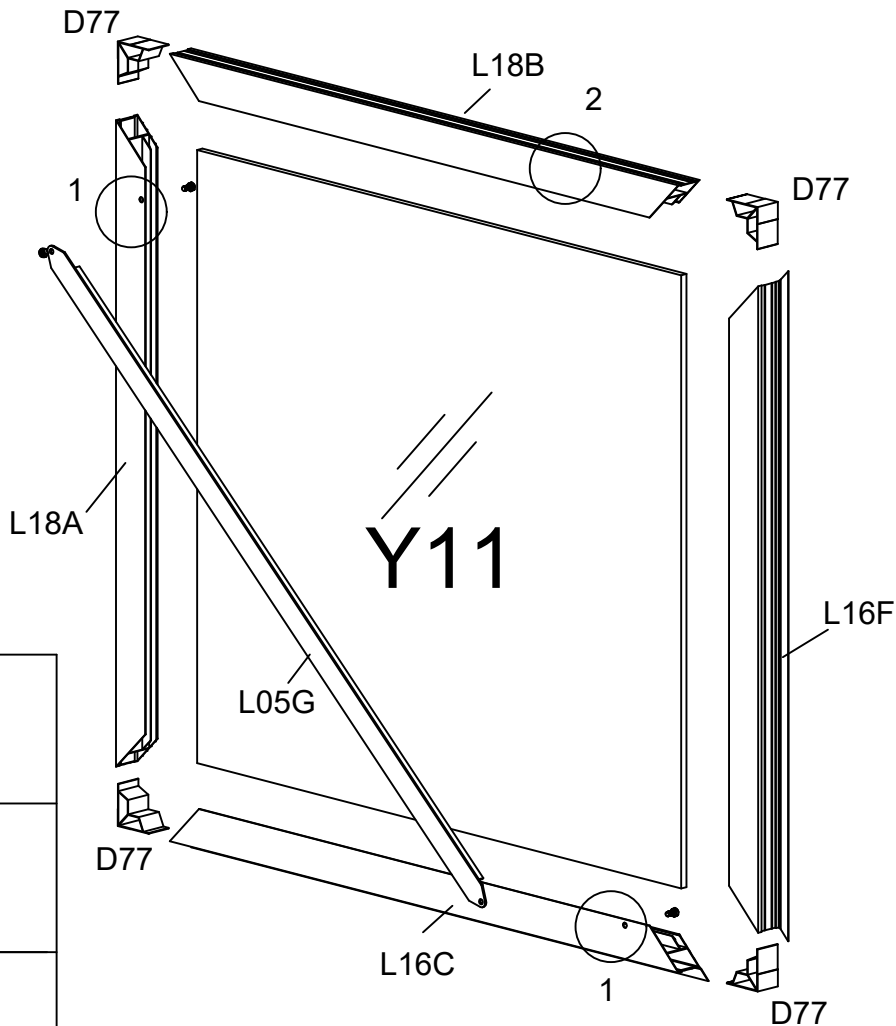
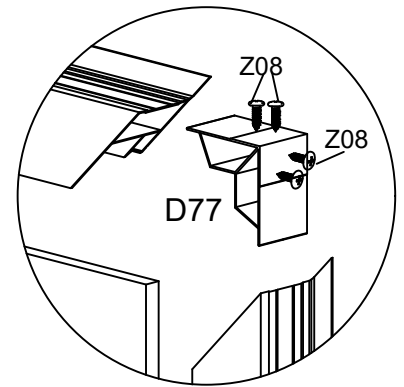
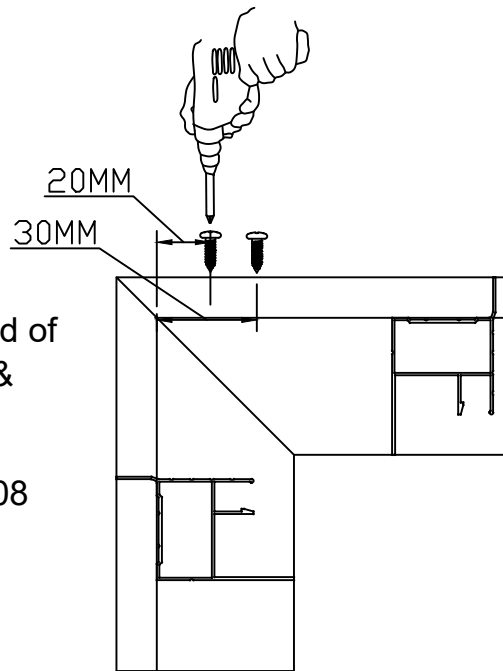

Door-R2 Assembly

Insert Connector D77 into each end of the profiles L16C & L16F & L18A & L18B, and then mark the distance from each end about 20/30MM. Lastly, secure them with screws Z08 using the powered screw-driver.

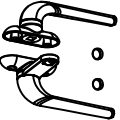



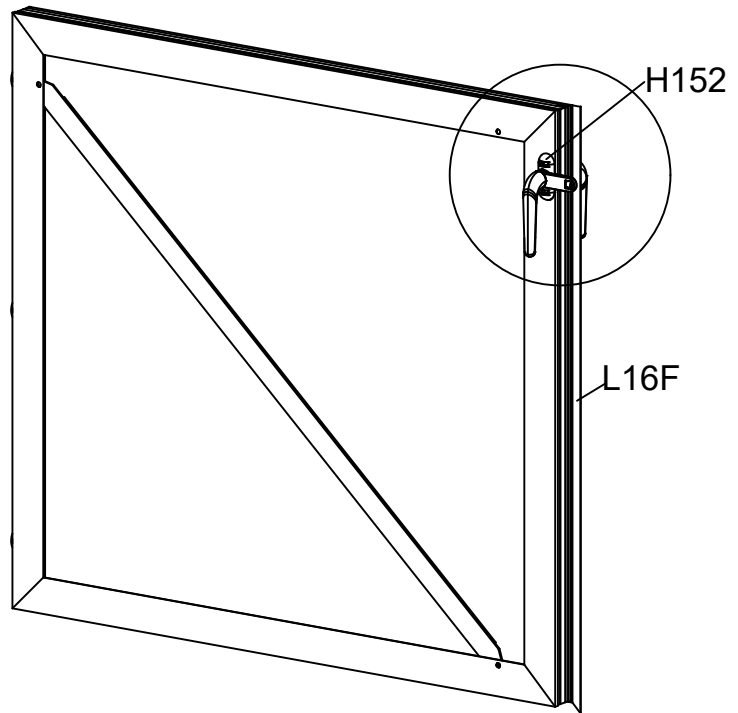



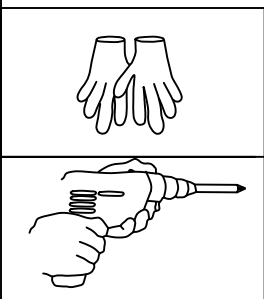
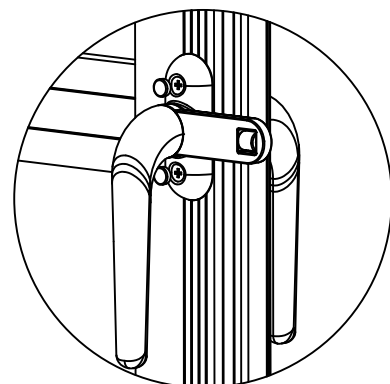
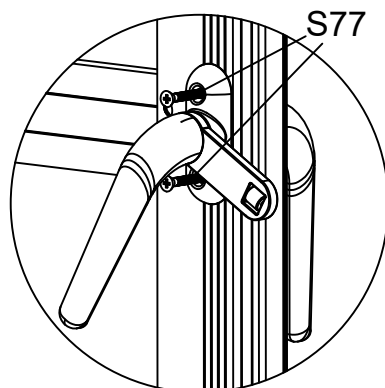
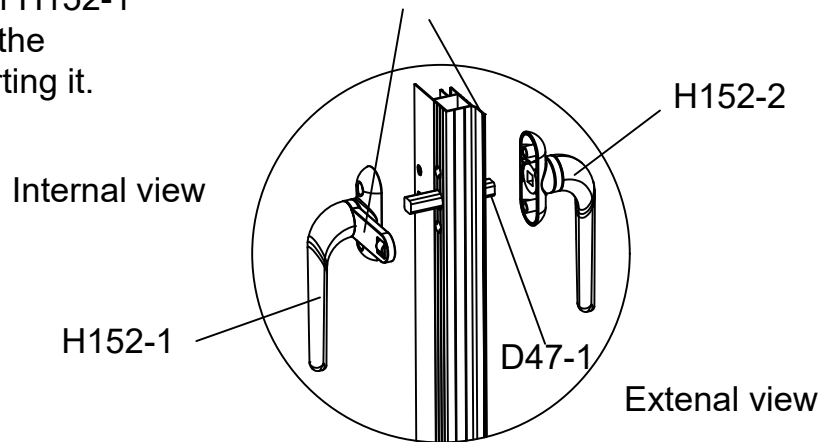

PART	NO	QTY
	H152	1
	D47-1	1
	S77 M4X50	2



After installing the door, attach handle H152.
 First, insert D47 into the door hole, then install H152.
 When installing, ensure that the long tongue of H152-1
 faces towards the edge of the door, and align the
 square hole of H152-1/2 with D47 before inserting it.
 attach the decorative cover.







Pay attention to the installation direction

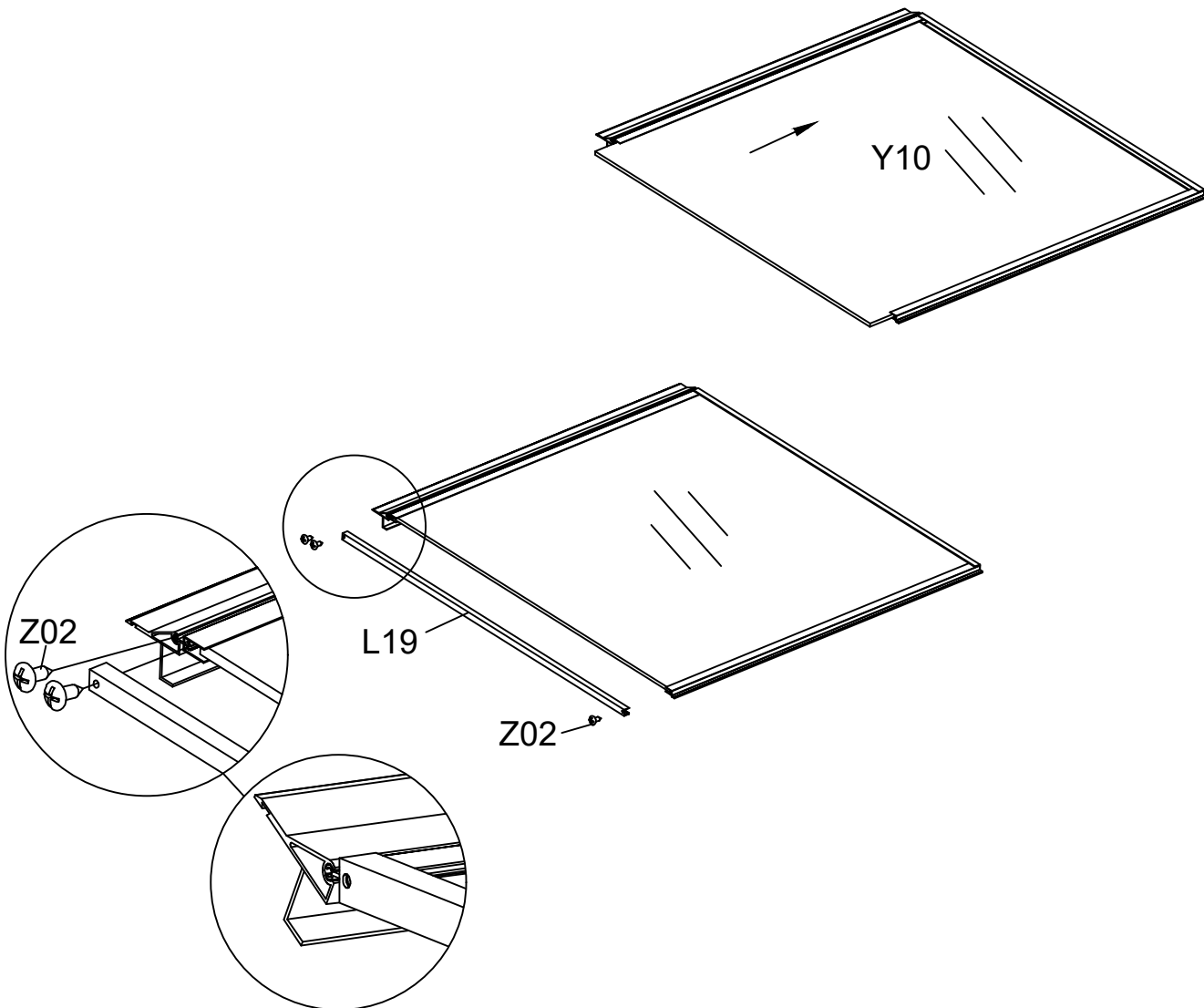
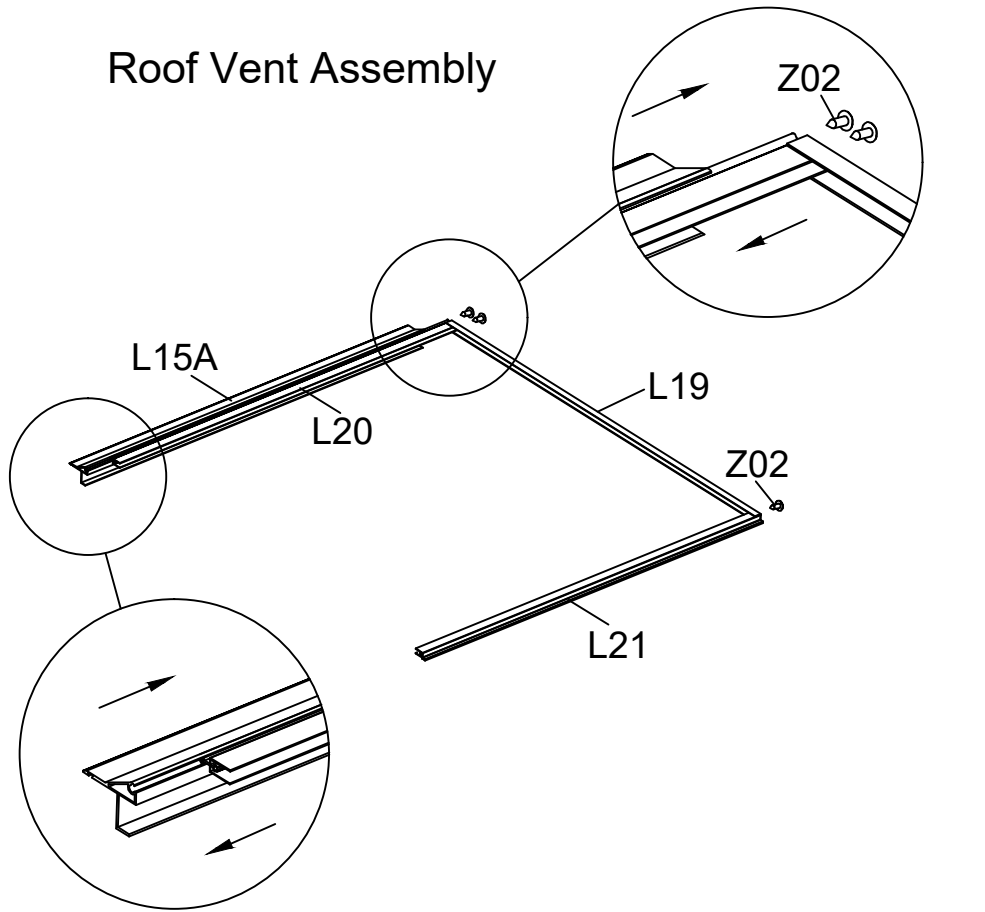

PART	NO.	QTY.
	L15A	1
	L19	2
	L20	1
	L21	1
	Z02 Ø4X16D	6
	Z04 Ø4X8	4
	Y10	1

Roof Vent Assembly



PART	NO.	QTY.
	L08A	6
	L08B	4
	A52	2
	A53	2
	A54	6
	J01	4
	J03	6

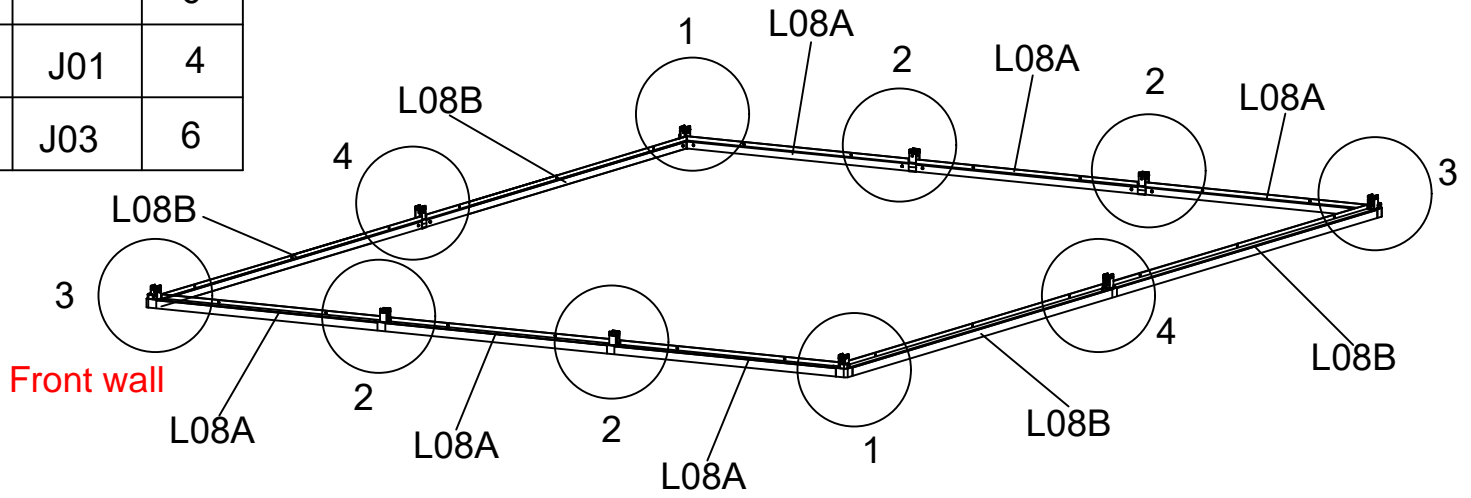



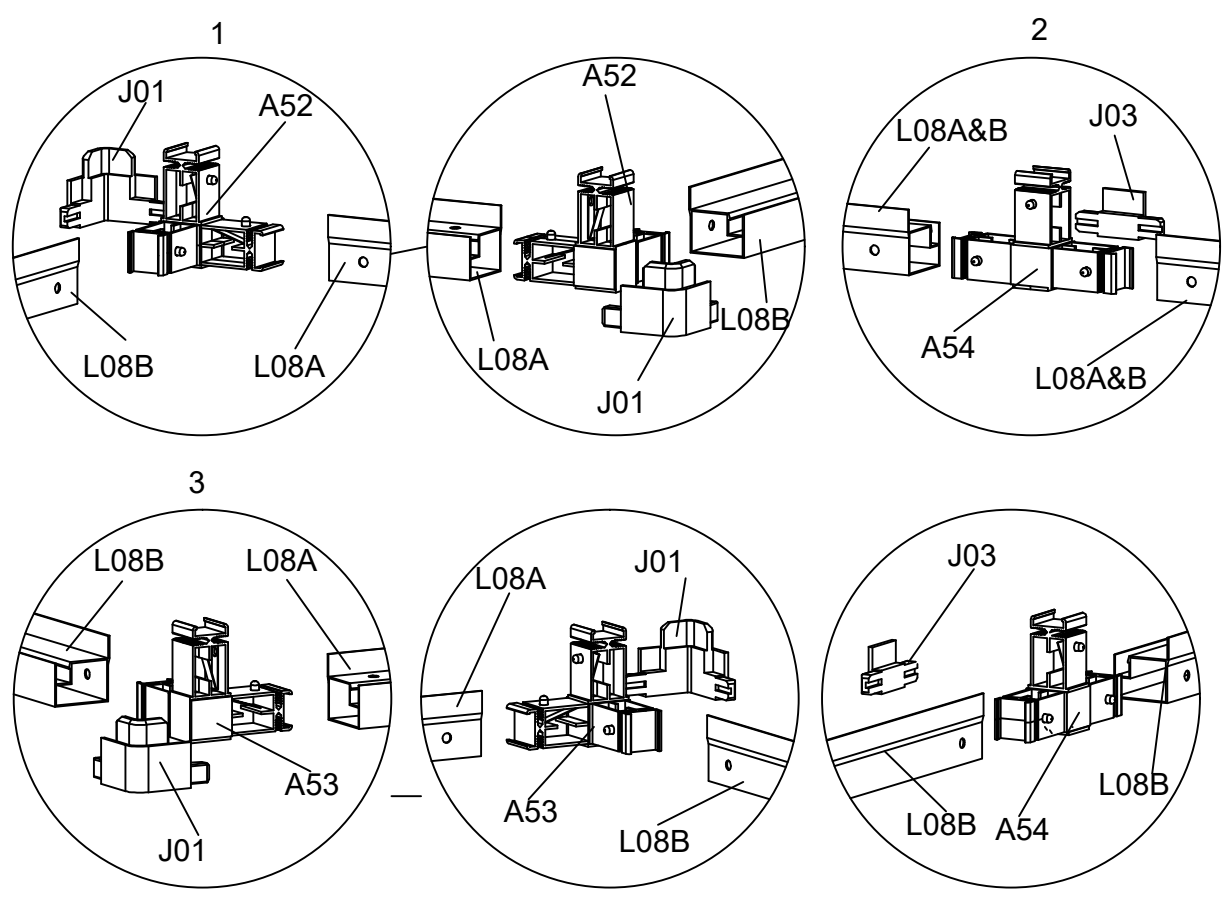



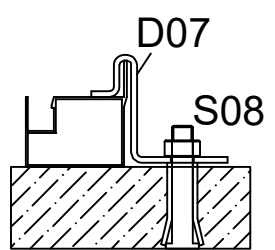

Front wall



Assemble all D07 followed by previous Page 16 after each base profile is connected.



PART	NO.	QTY.
	L01A	2
	L03A	2
	L03C	1
	L03D	1
	L07	2
	A09	1
	A10	1
	A12	2

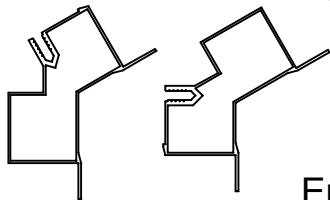
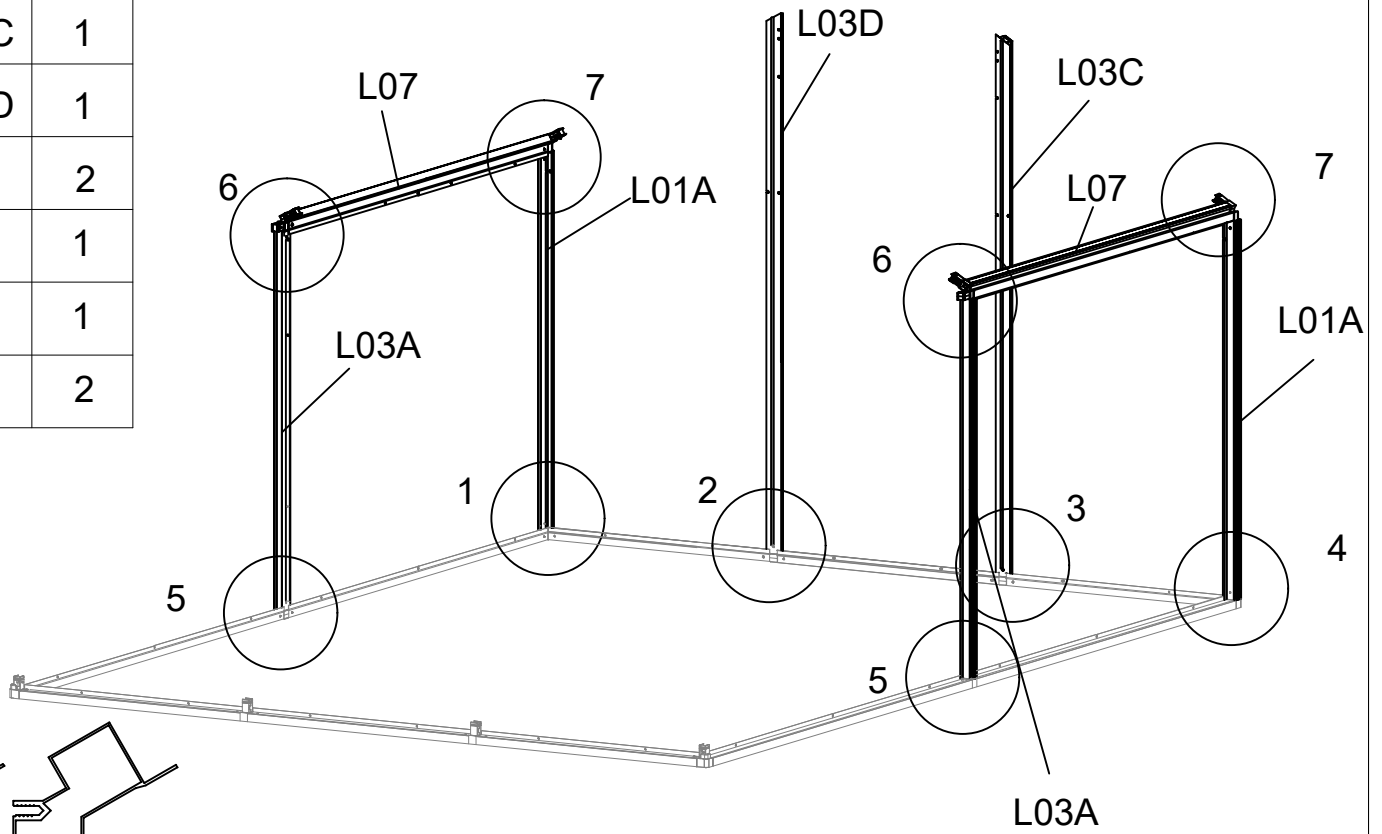





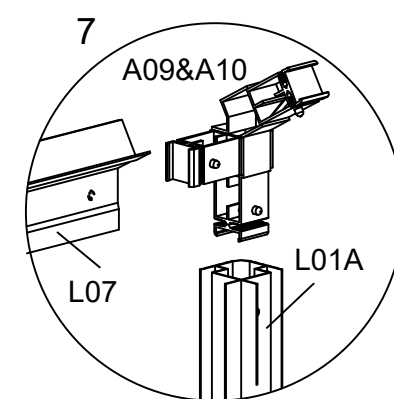
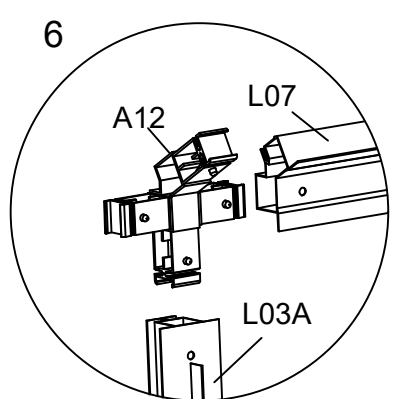
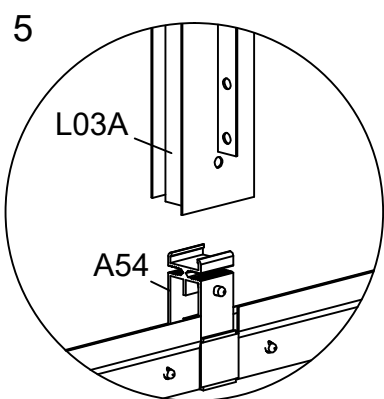
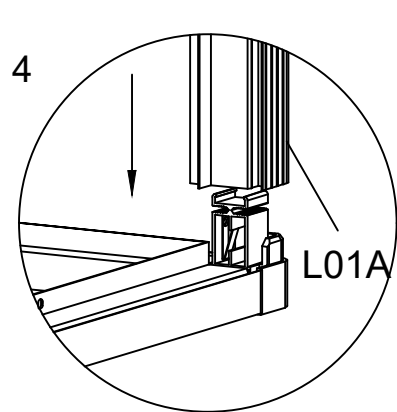
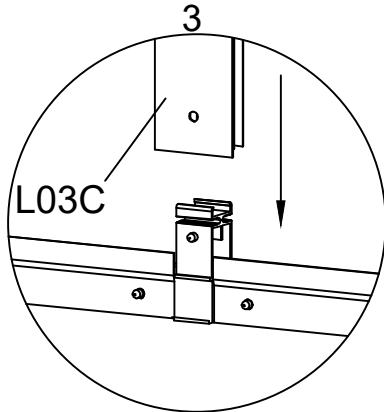
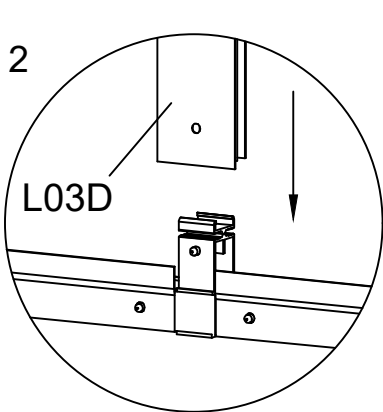
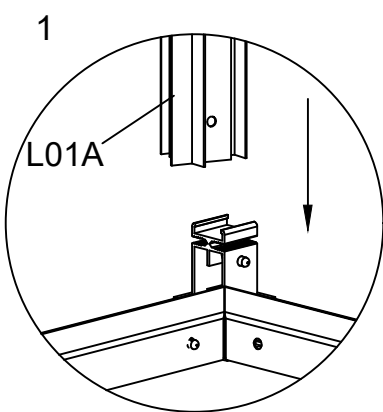

CORRECT

WRONG

Ensure orientation of the L07 profile is correct as per detail.





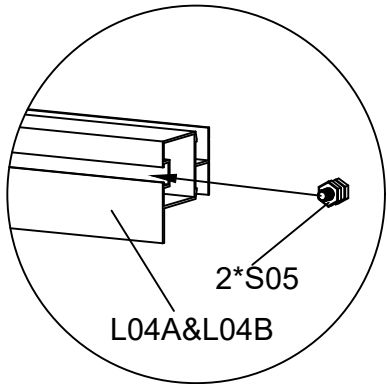
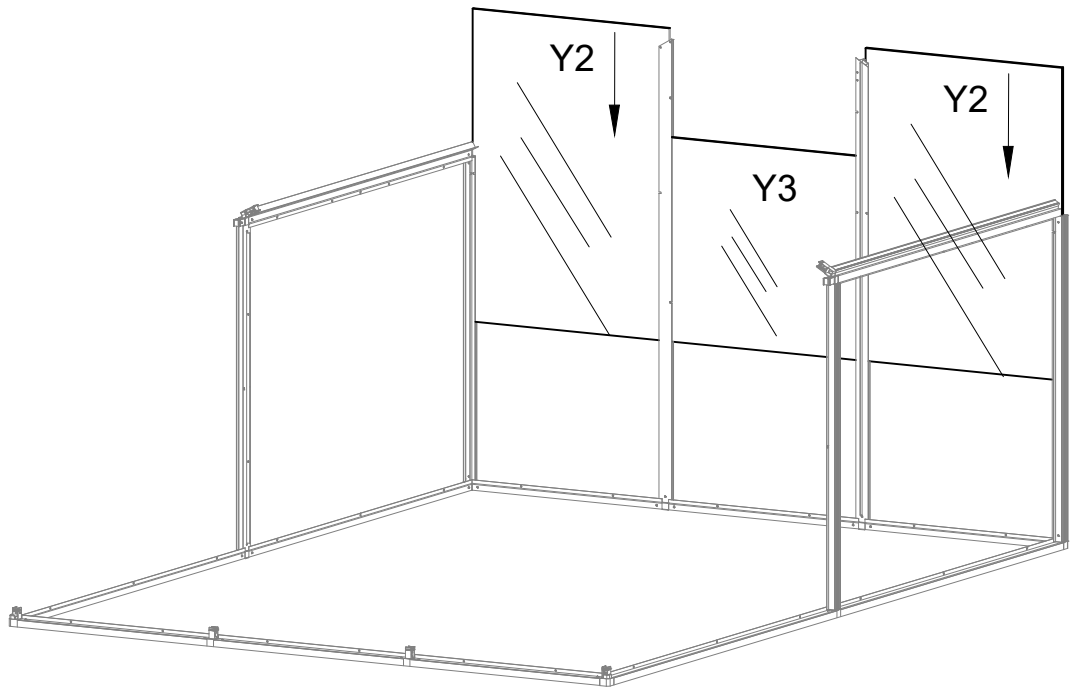

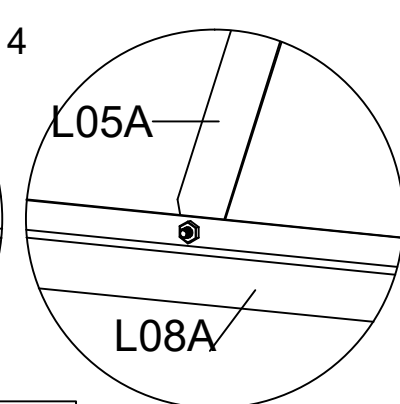
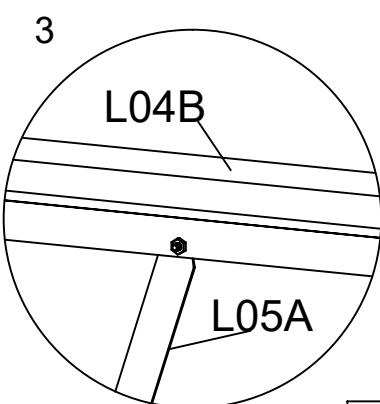
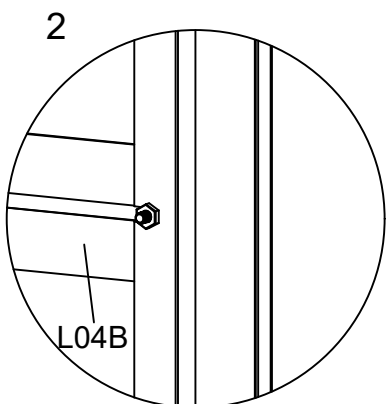
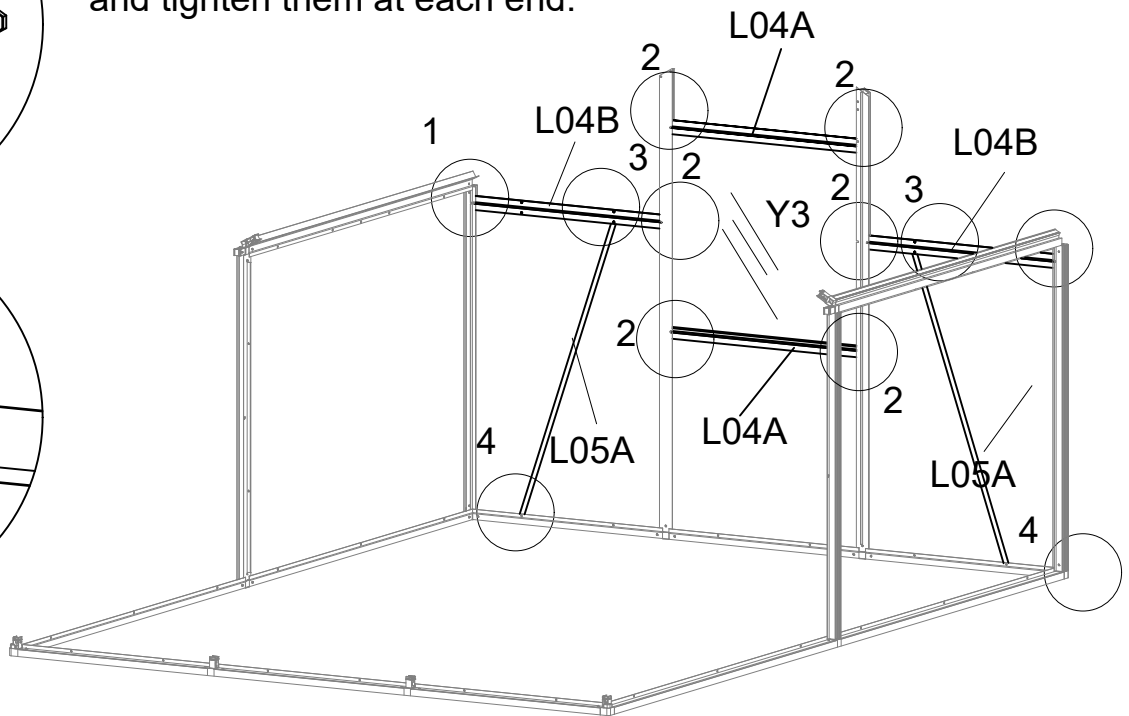
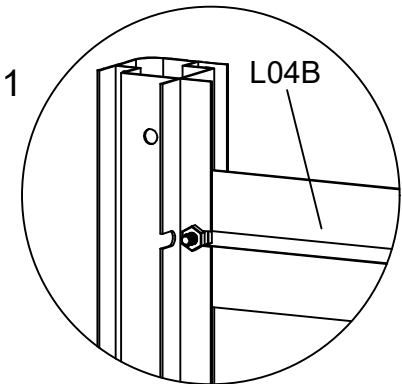

PART	NO.	QTY.
	L04A	2
	L04B	2
	L05A	2
	Y2	2
	Y3	2
	S05	12
	M6X12	
	M03	12
	M6	









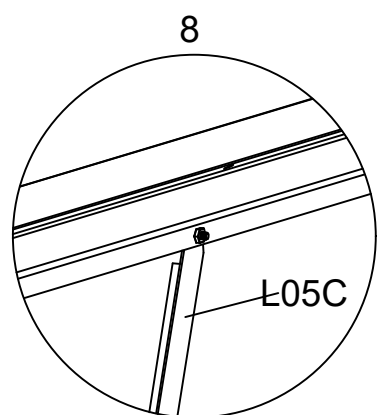
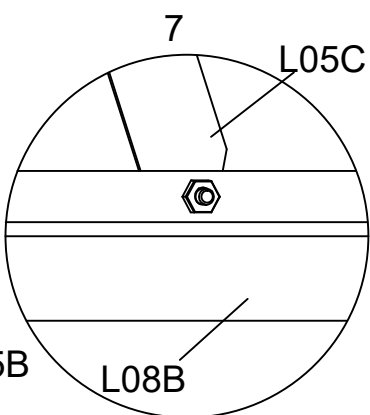
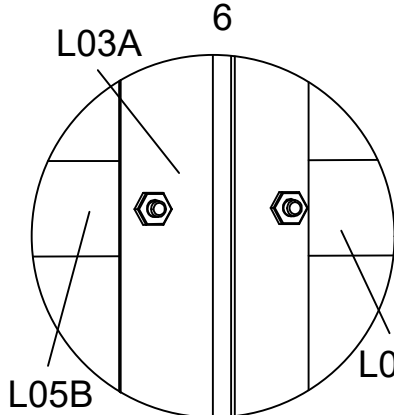
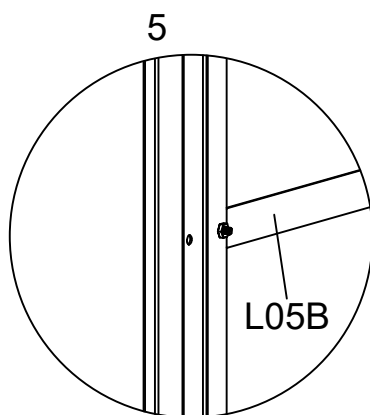
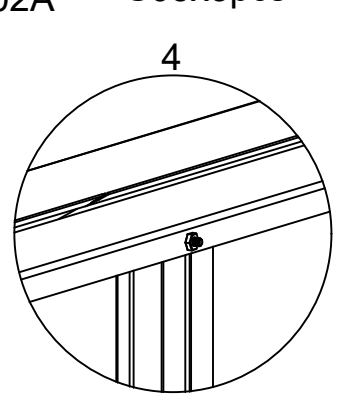
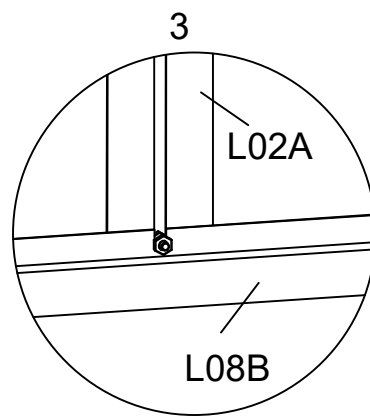
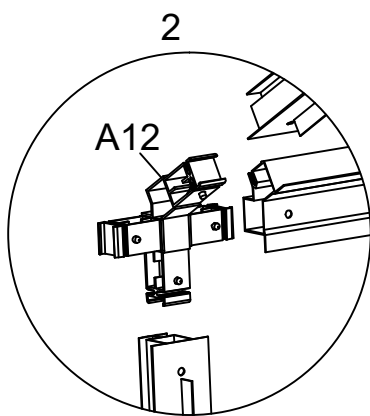
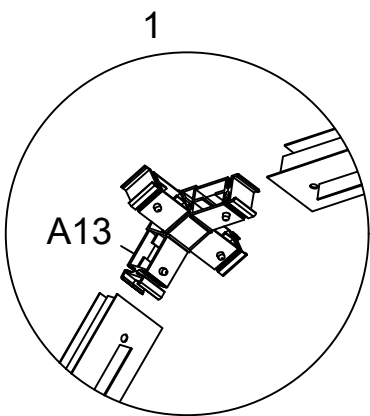
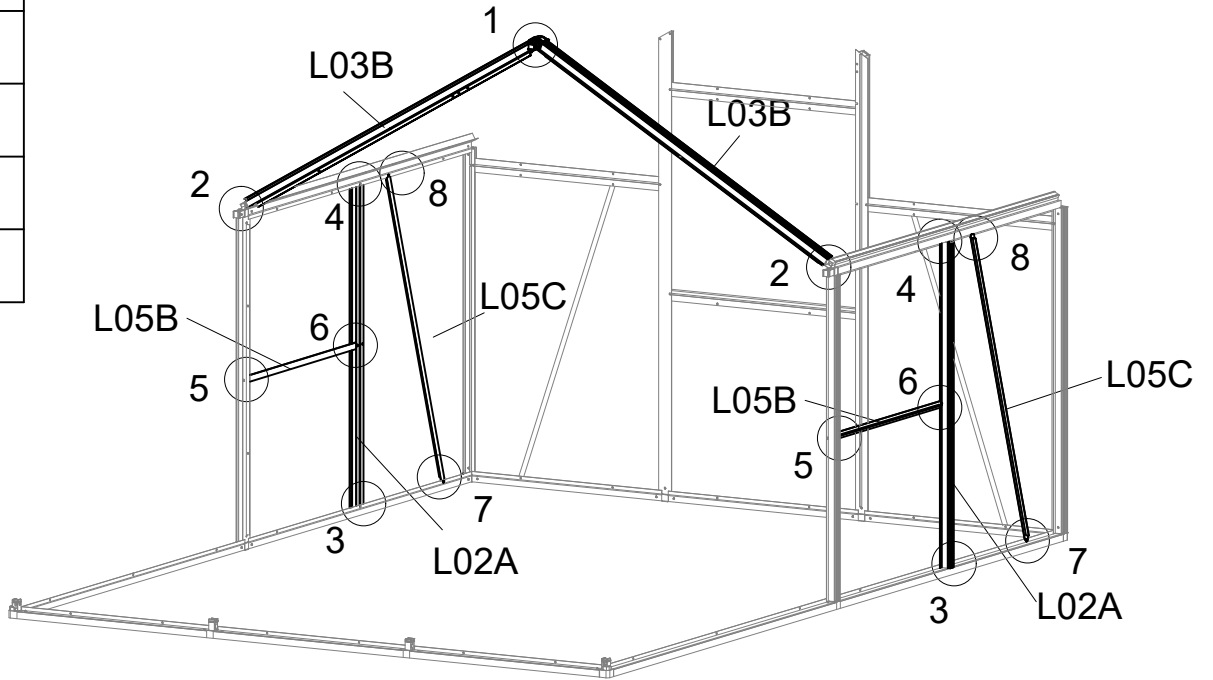





Slide 2xS05 into each L04A&L04B and tighten them at each end.



PART	NO.	QTY.
	L02A	2
	L03B	2
	L05B	2
	L05C	2
	A13	1
	S05	14
	M6X12	
	M03	12
	M6	



PART	NO.	QTY.
	L01A	1
	L01D	1
	L02A	2
	L07	2
	L05B	2
	L05C	2
	L05E	2
	L05F	4
	A09	1
	A10	1
	S05	20
	M6X12	
	M03	18
	M6	

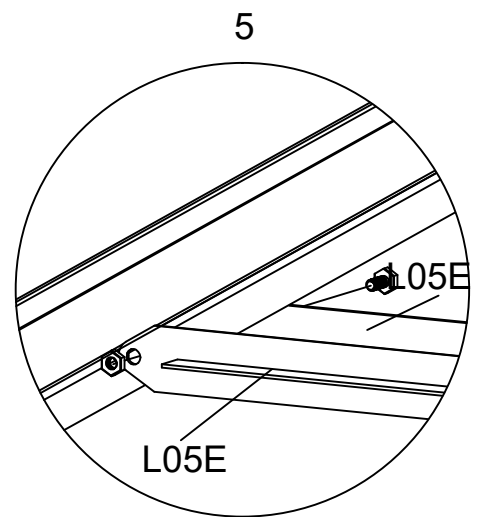
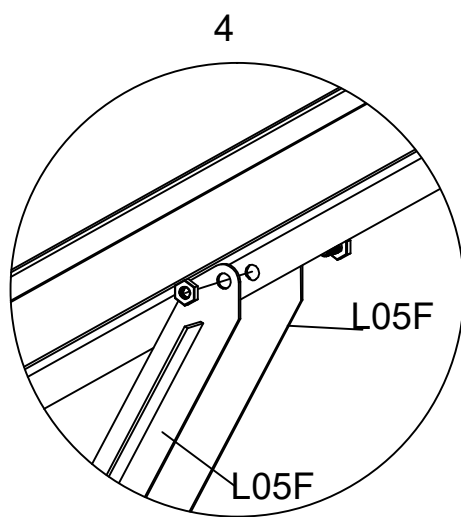
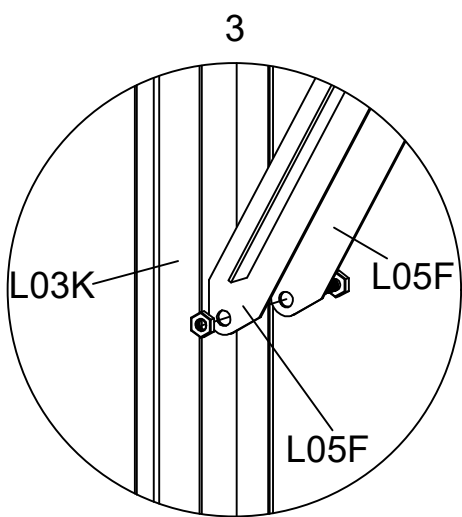
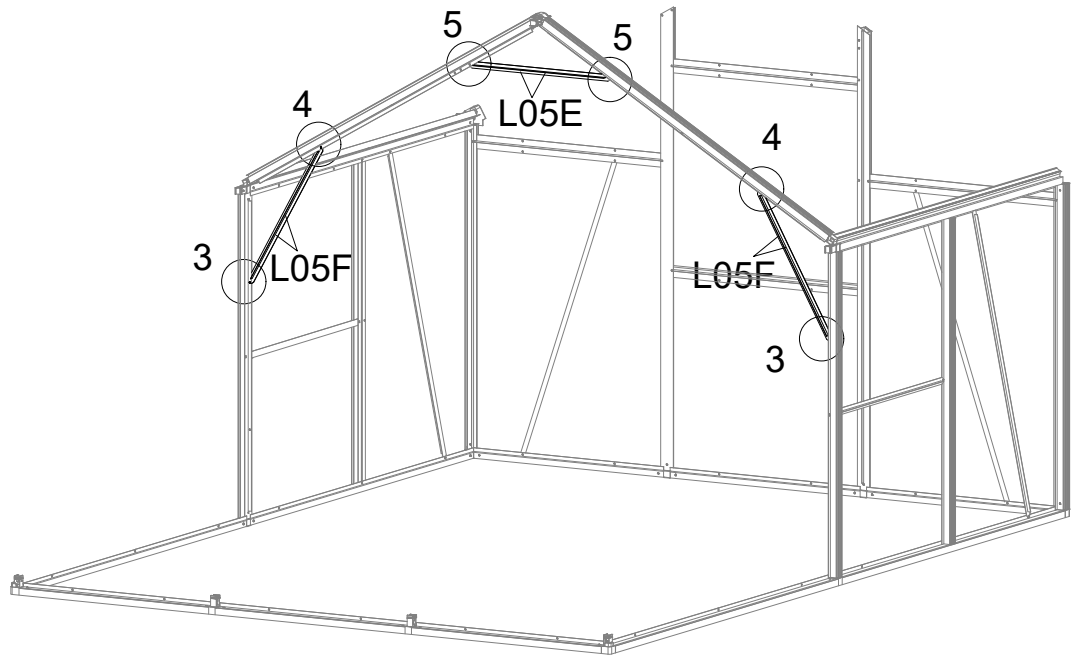

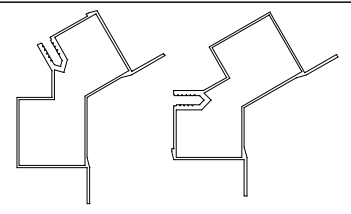
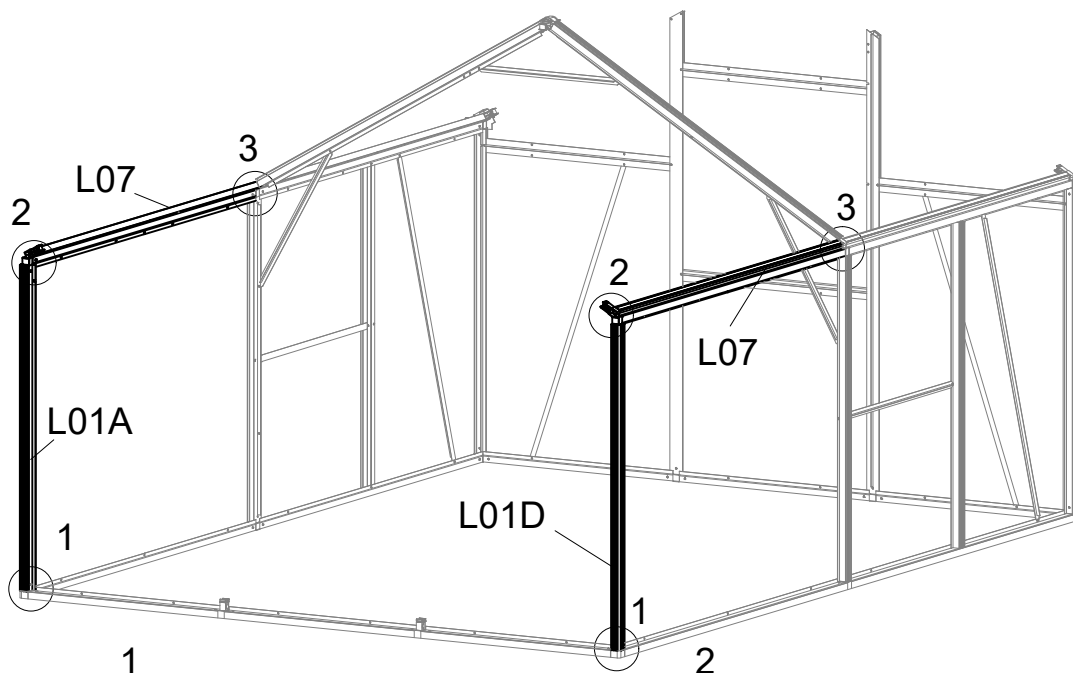





✓
CORRECT

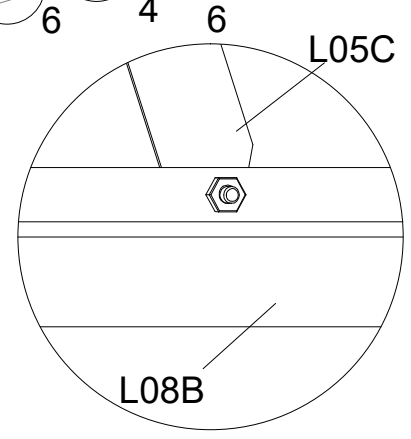
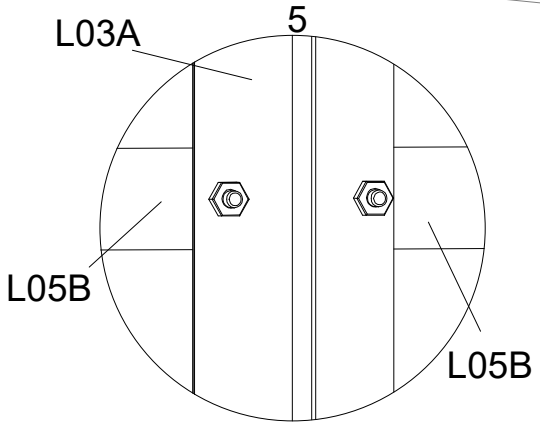
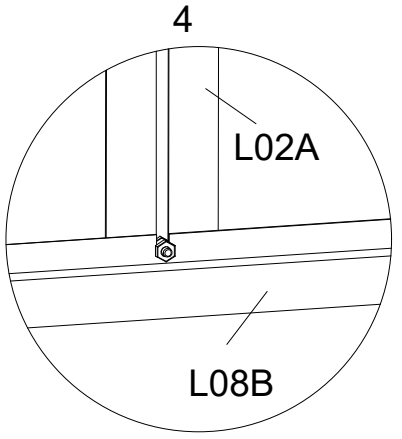
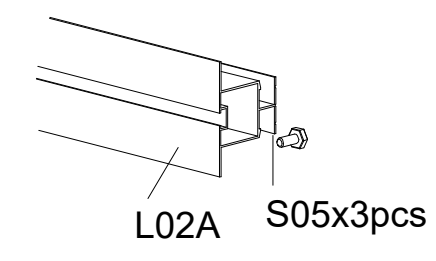
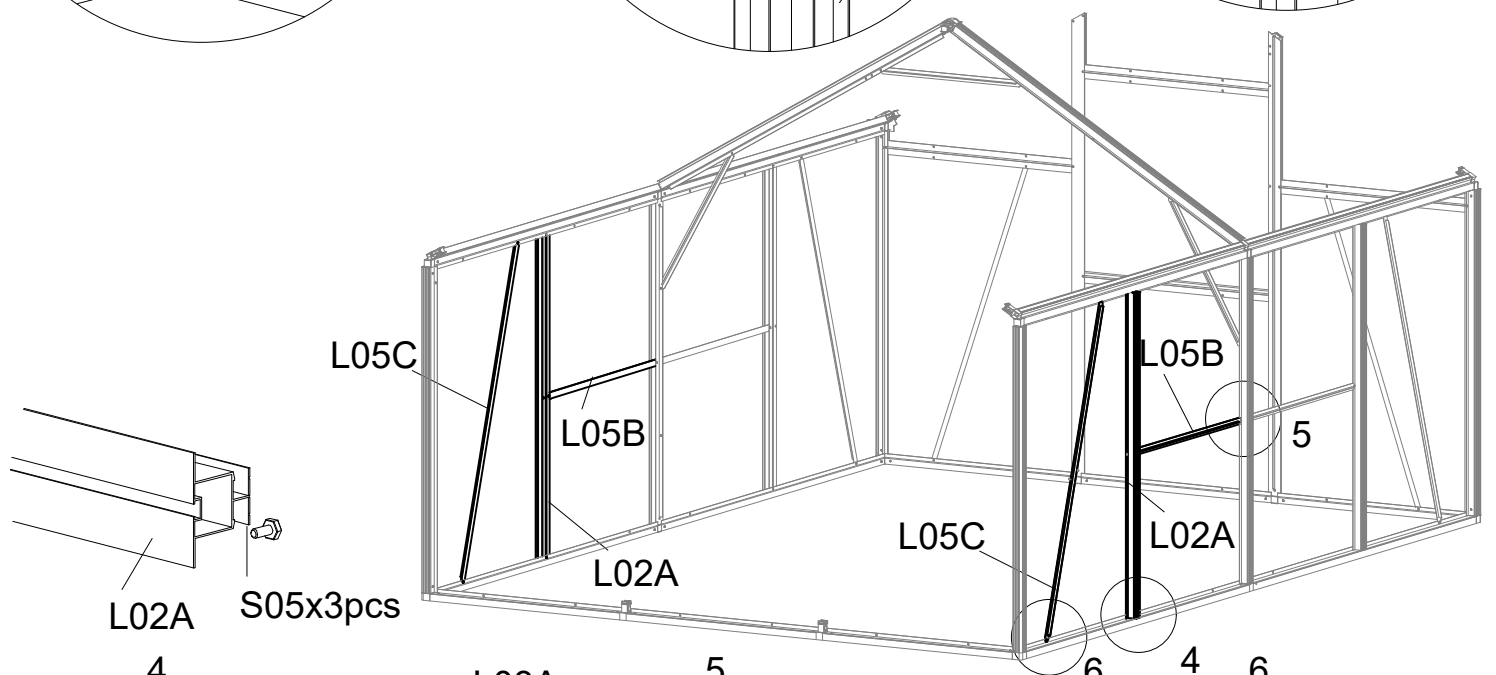
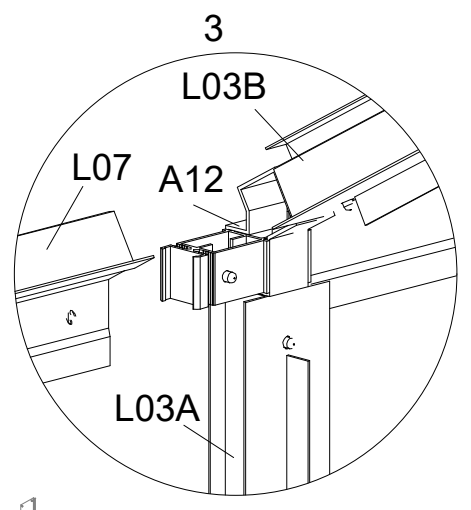
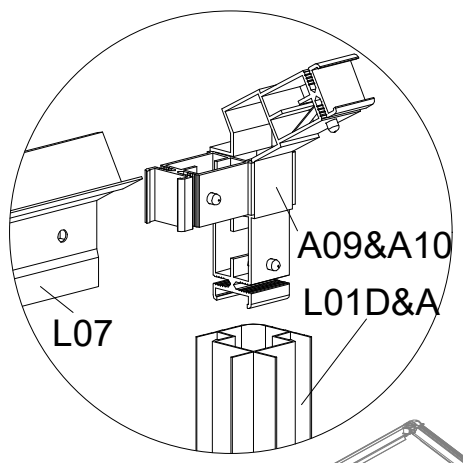
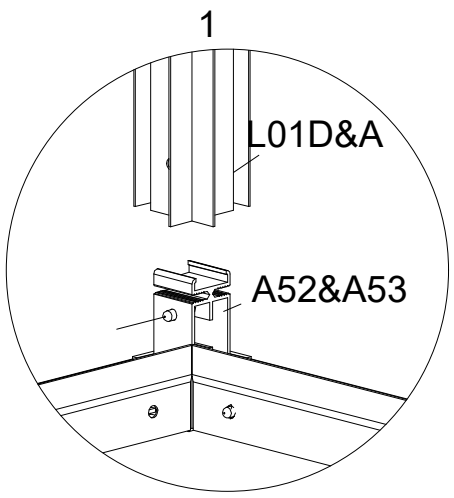



✗
WRONG

Ensure orientation of the L07 profile is correct as per detail.

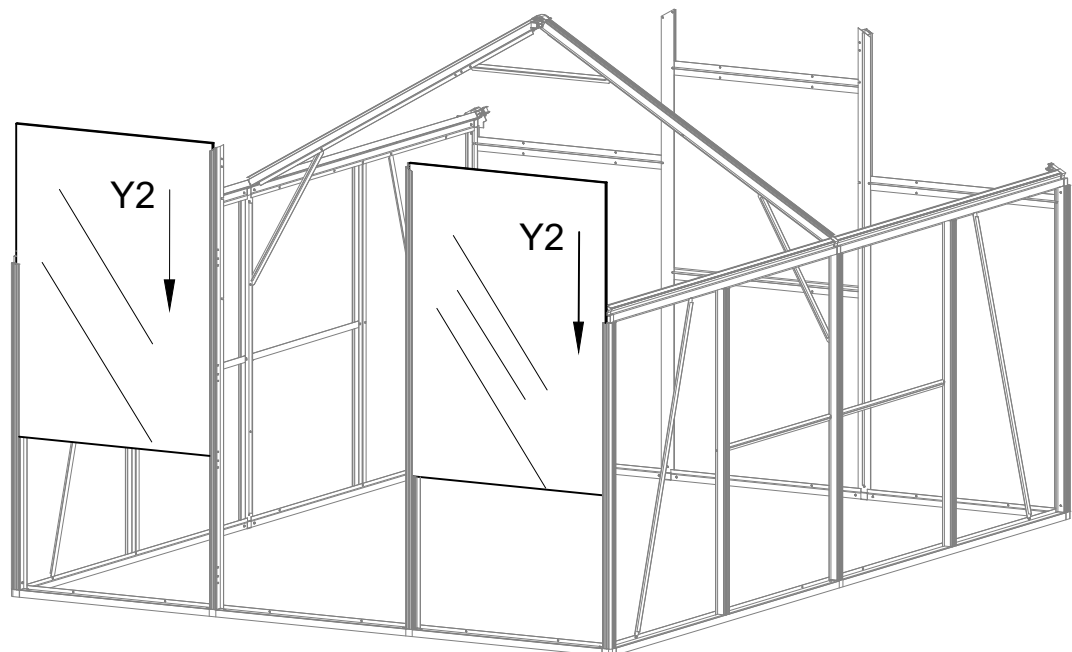
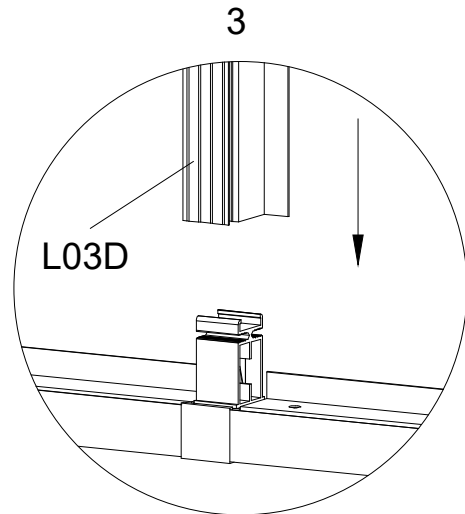
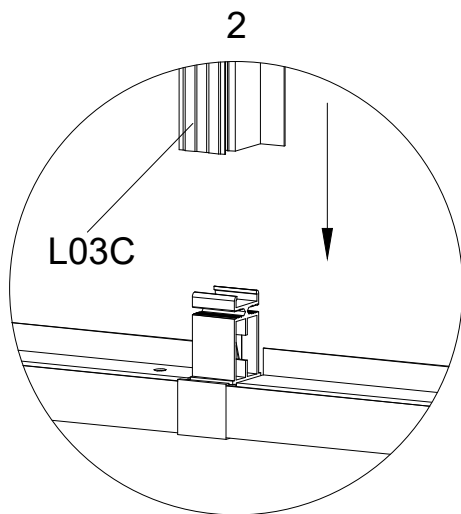
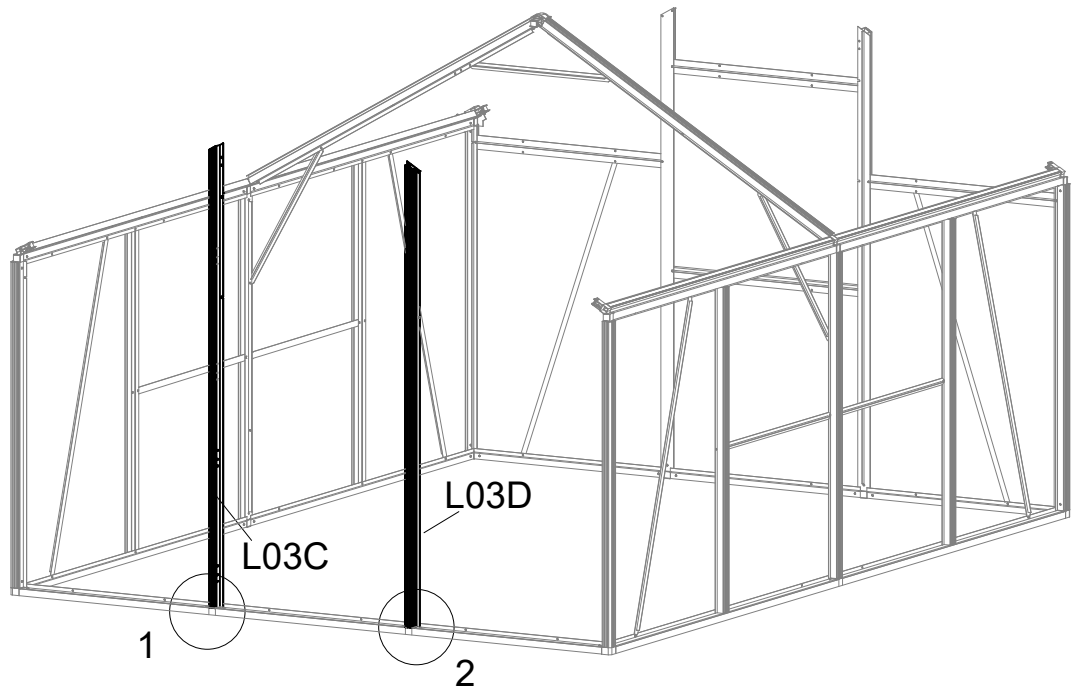

PART	NO.	QTY.
	L03C	1
	L03D	1
	Y2	2





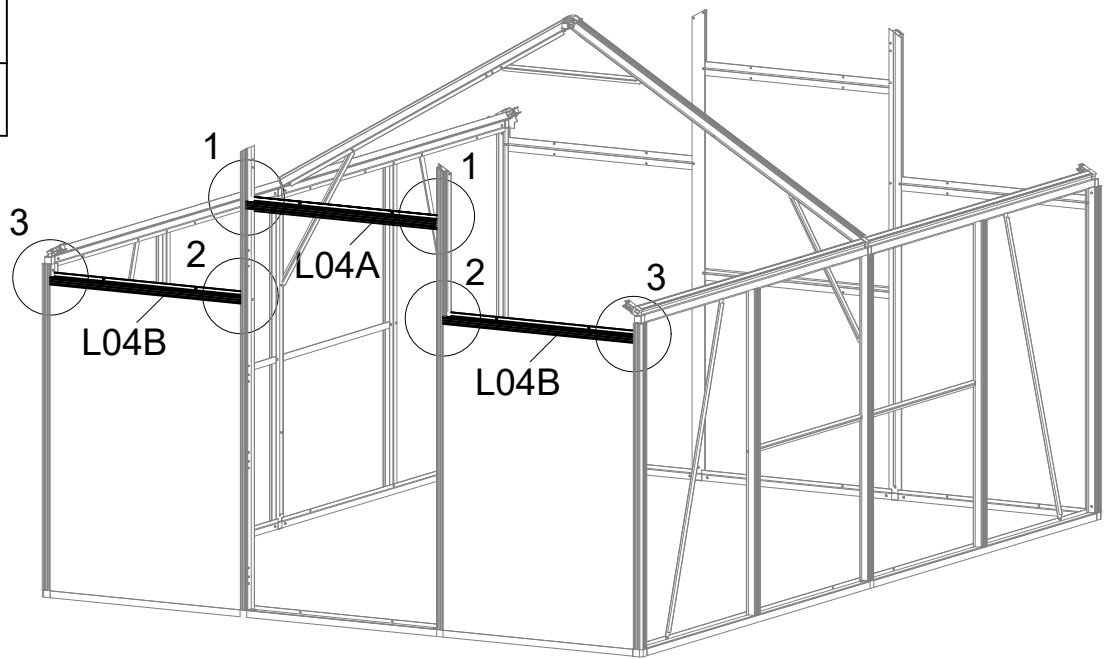

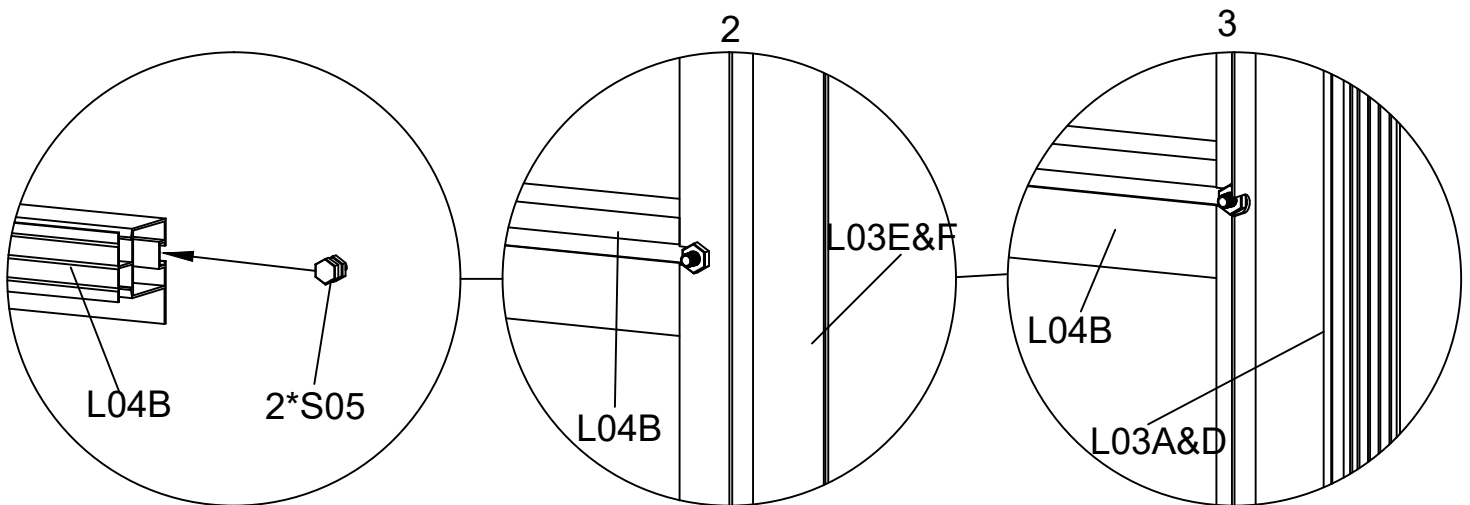
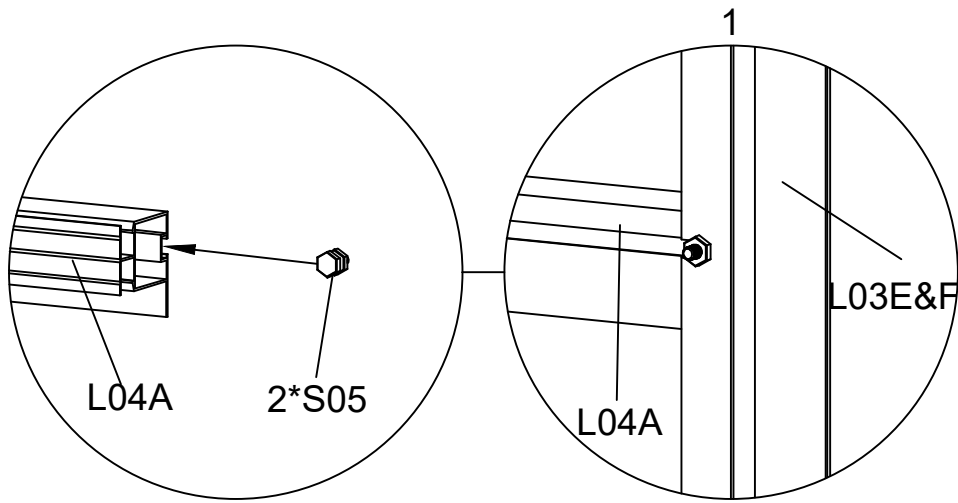

PART	NO.	QTY.
	L04A	1
	L04B	2
	S05	6
	M6X12	
	M03	6
	M6	





Slide 2xS05 into each L04A & B and tighten them at each end.



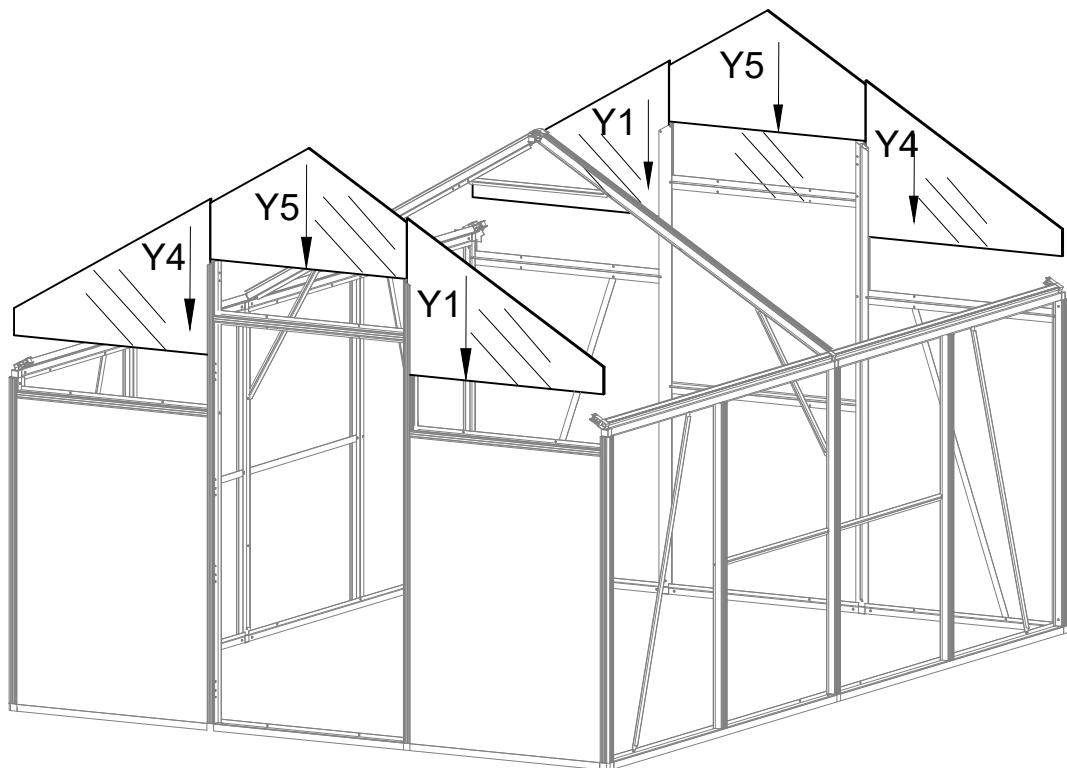
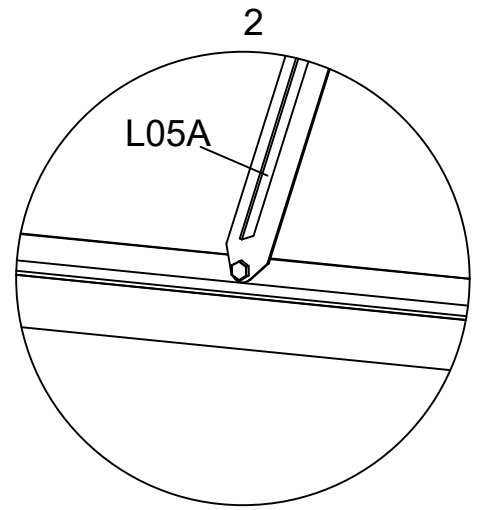
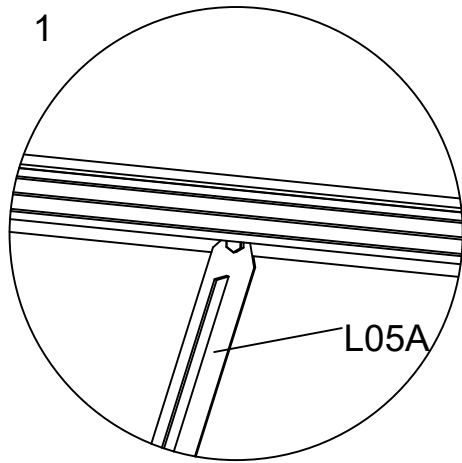
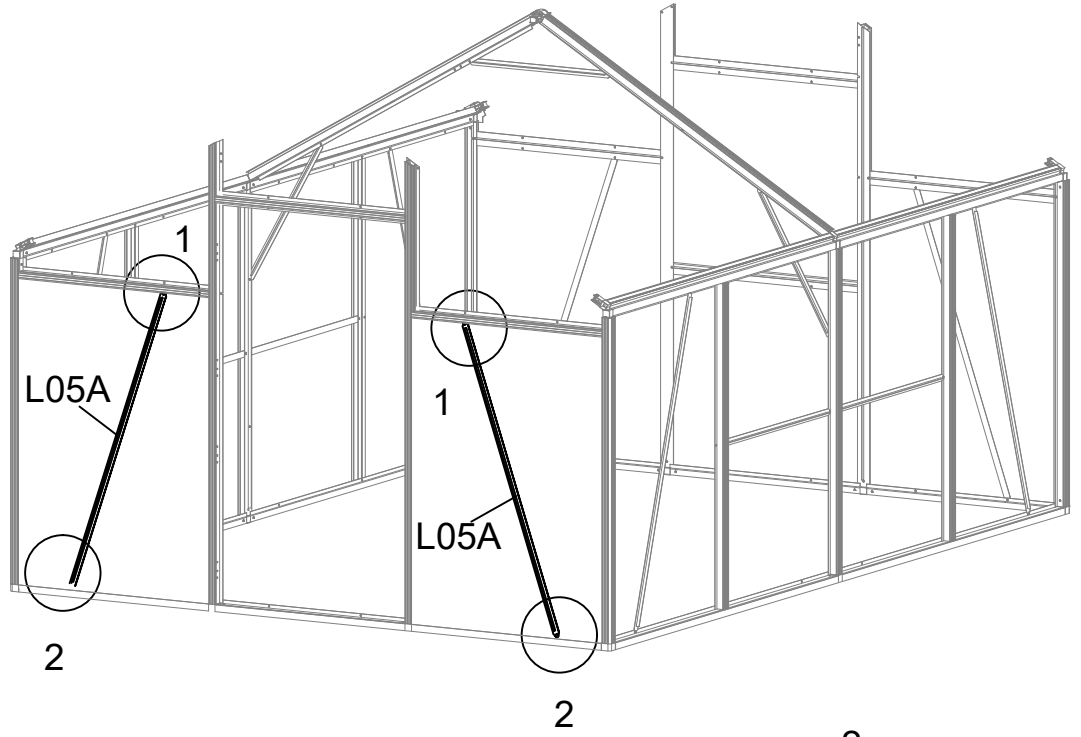

PART	NO.	QTY.
	L05A	2
	Y1	2
	Y4	2
	Y5	5
	S05	4
	M6X12	
	M03	4
	M6	





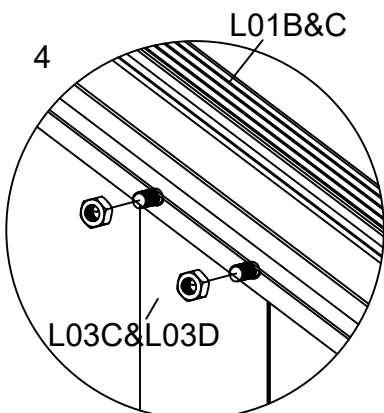
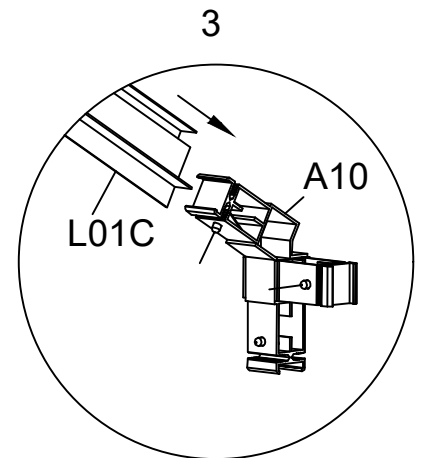
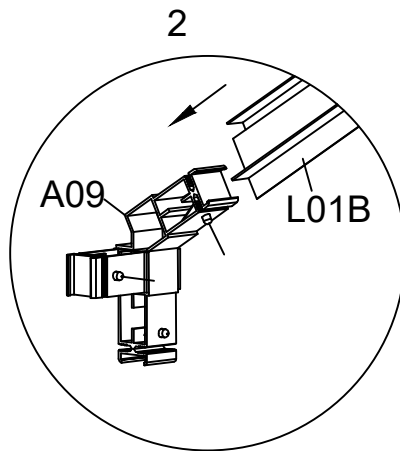
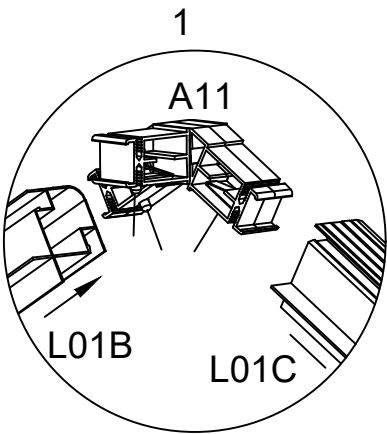
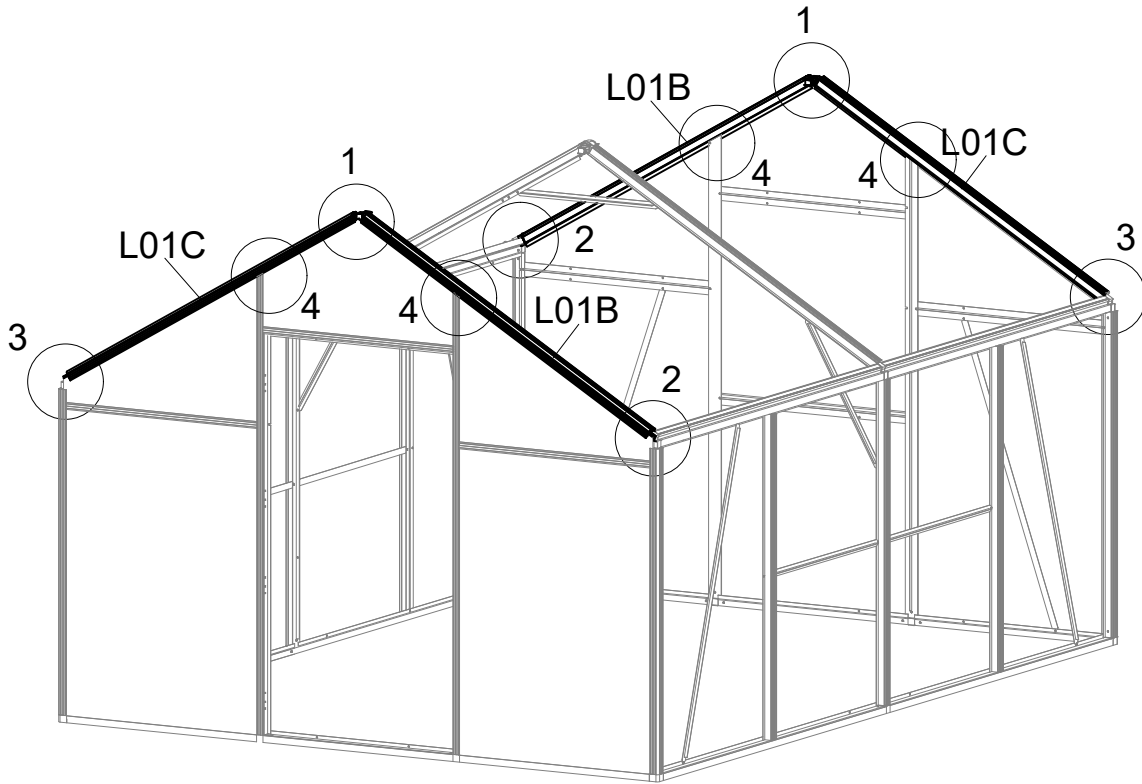

PART	NO.	QTY.
	L01B	2
	L01C	2
	A11	2

Note: please insert upper roof supports but do not lock in place until you have aligned the polycarbonate inserts.

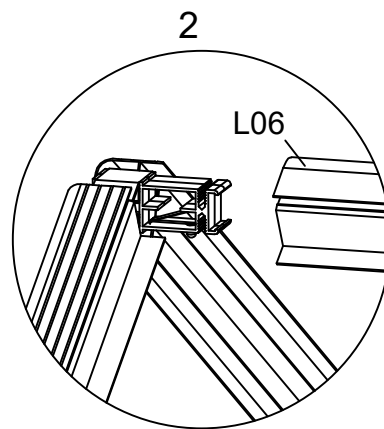
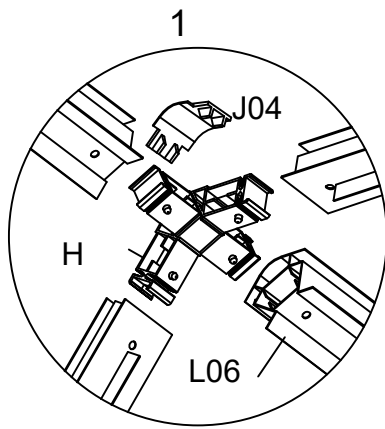
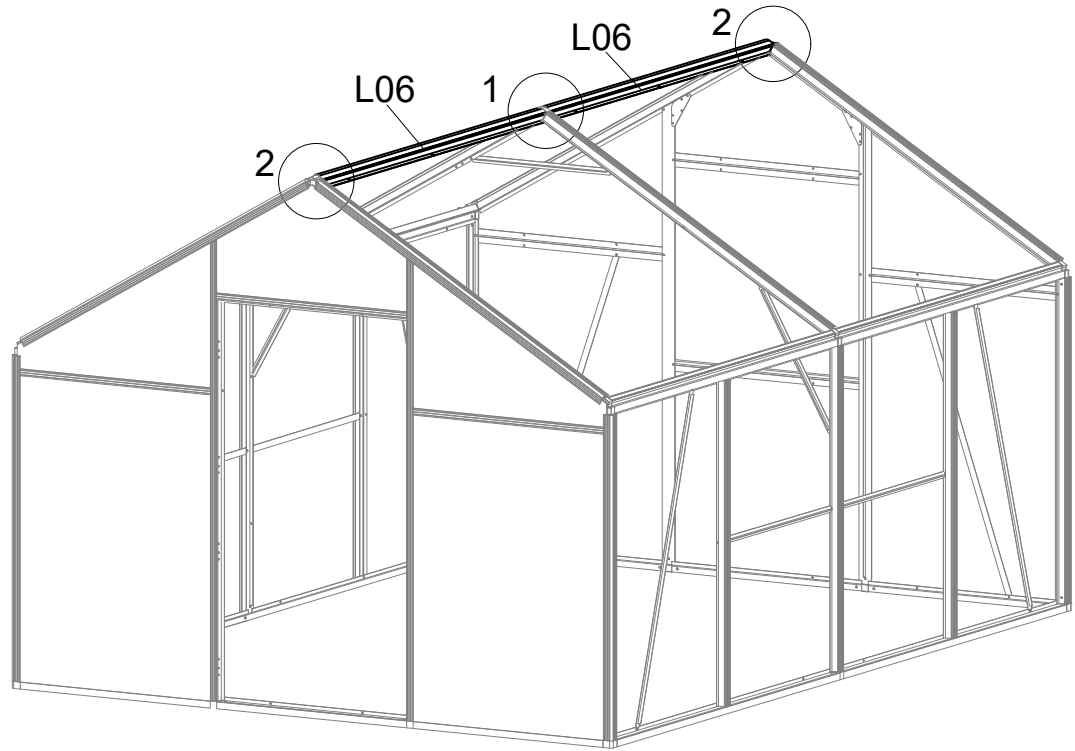

PART	NO.	QTY.
	L06	2
	J04	1





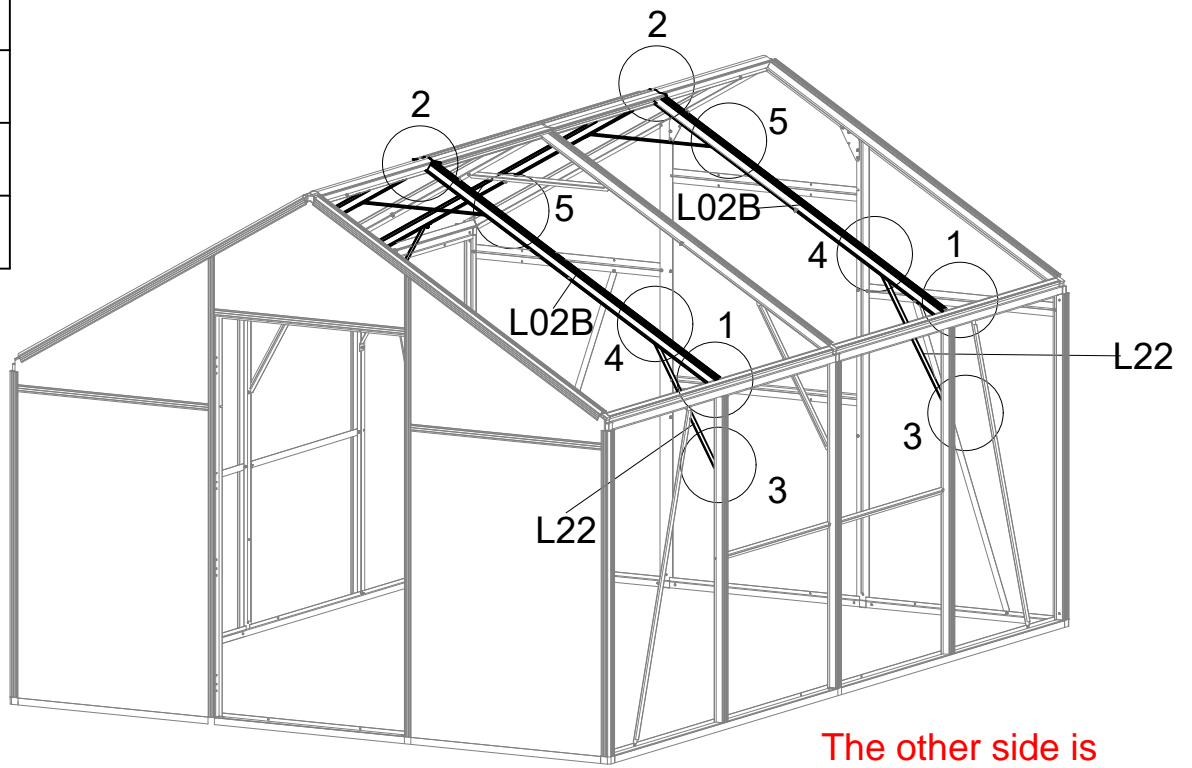





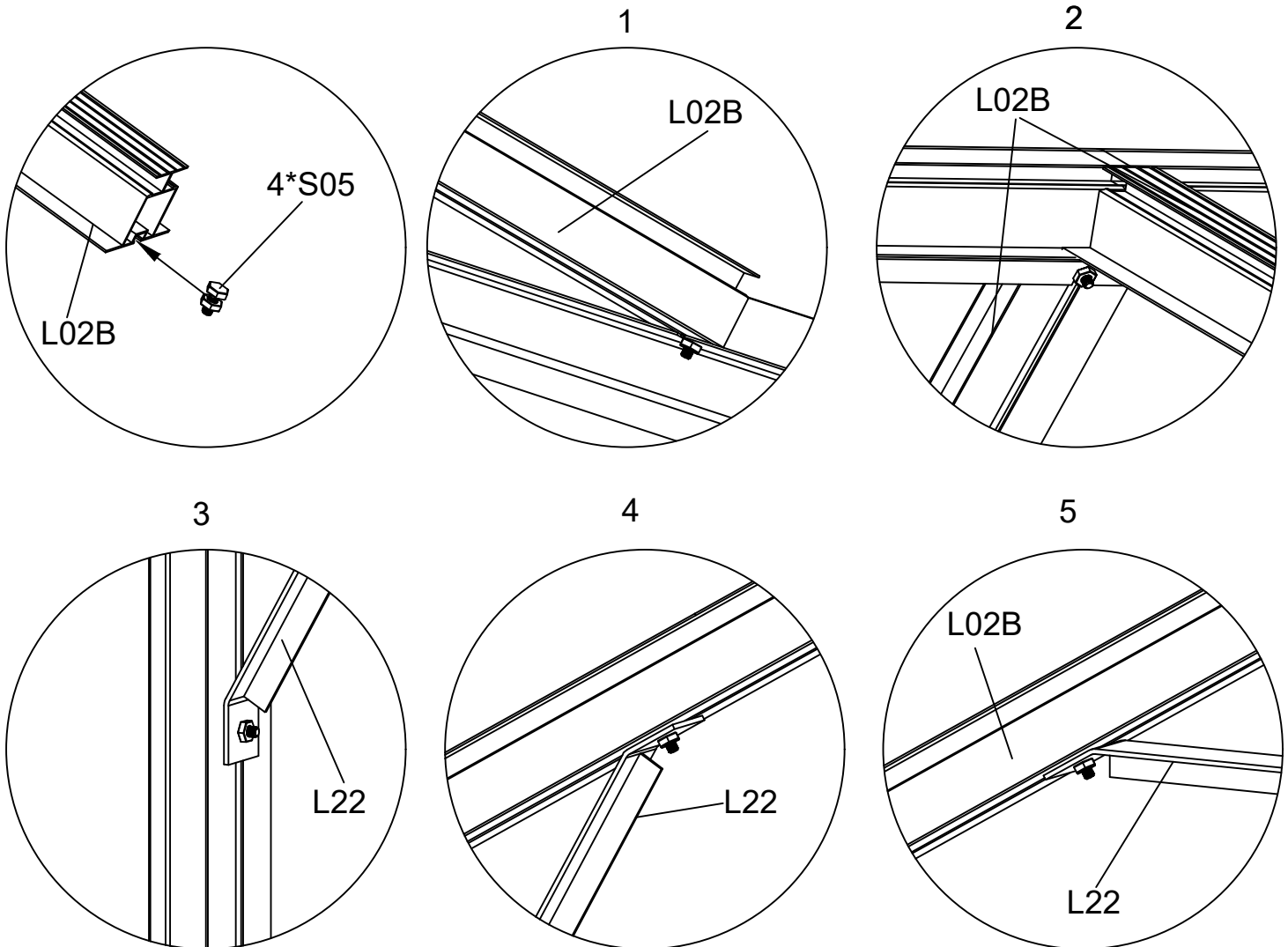

PART	NO.	QTY.
	L02B	4
	L22	6
	S05	16
	M6X12	
	M03	20
	M6	



The other side is installed the same way

Slide 4xS05 into each L02B and tighten them at each end.



PART	NO.	QTY.
	Roof Vent Assembly	4
	L04E	4
	L05D	4
	A01	8
	A69	4
	A70	4
	S05	32
	M6X12	
	S11	8
	M6X20	
	M03	40
	M6	

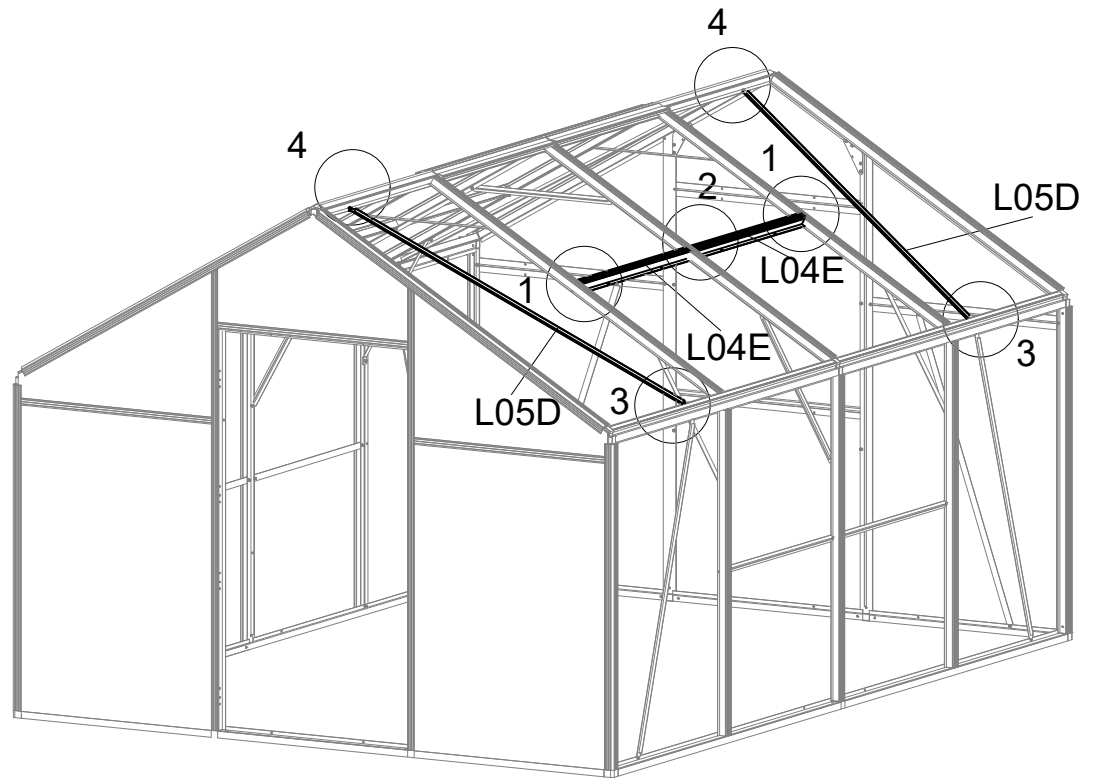



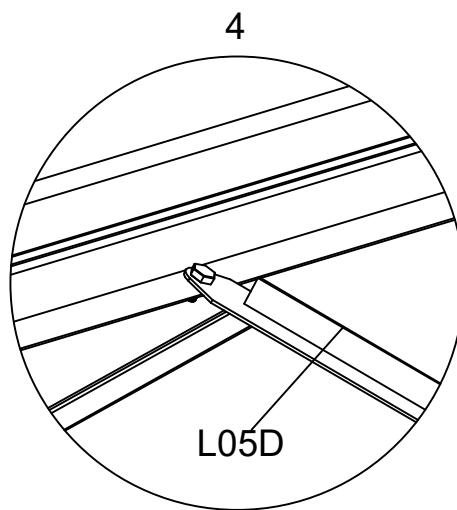
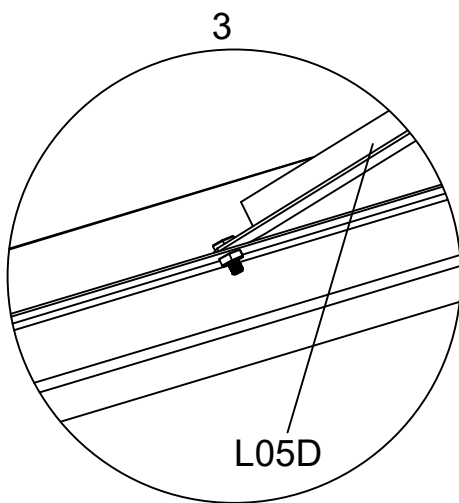
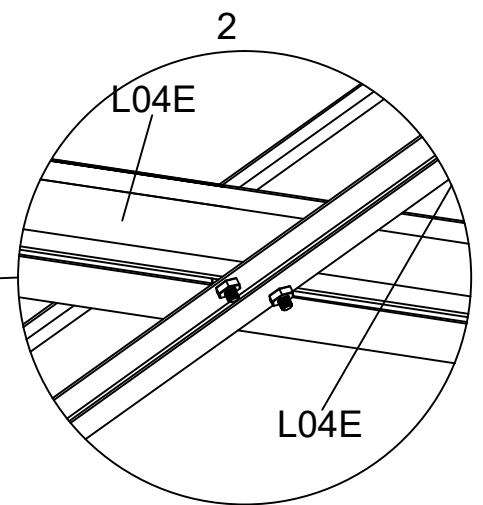
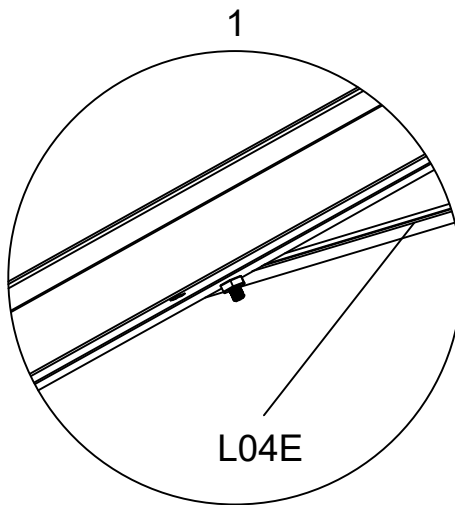
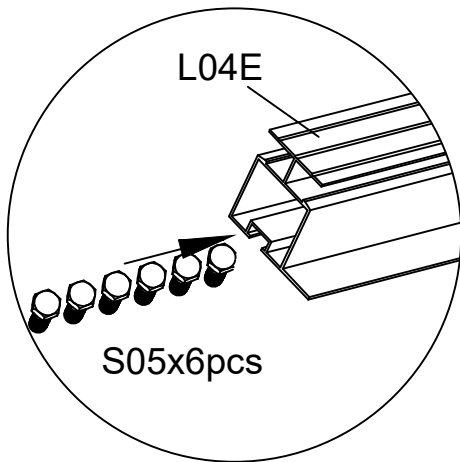

Pay attention to the cut edge of L04E which should be fixed, facing up.

The other side is installed the same way

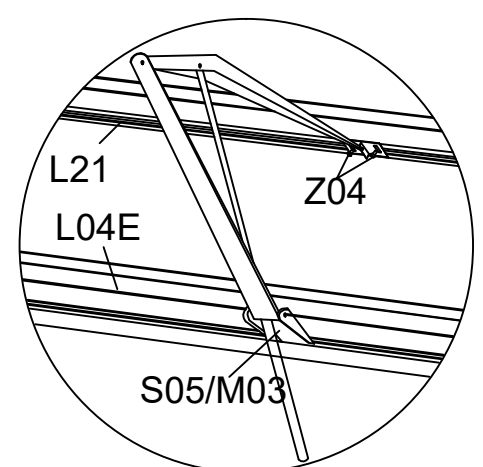
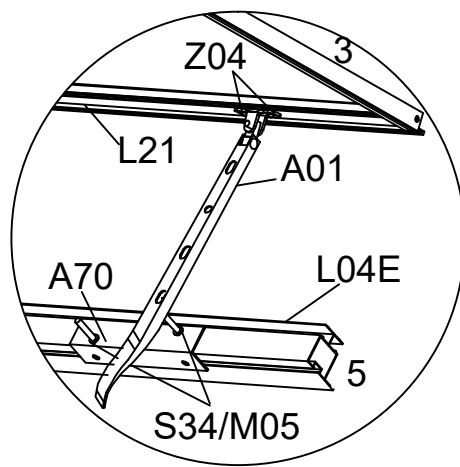
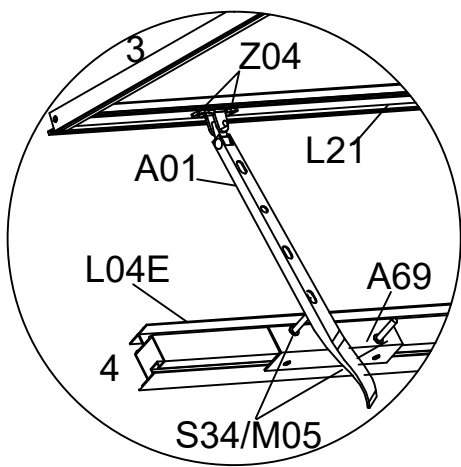
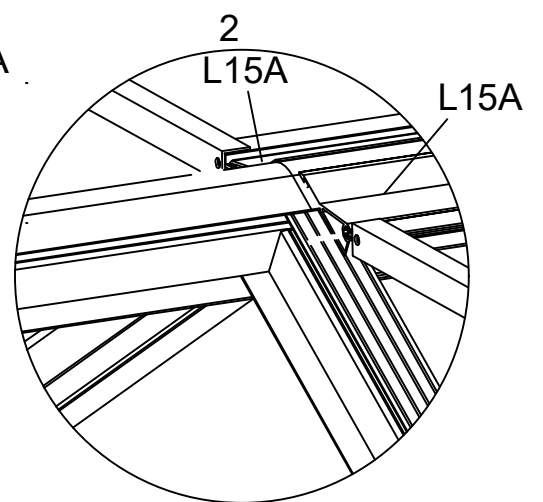
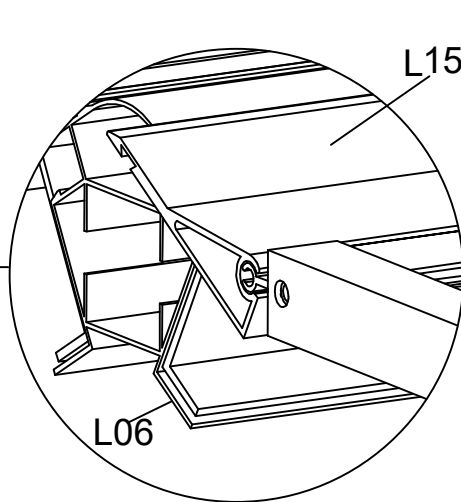
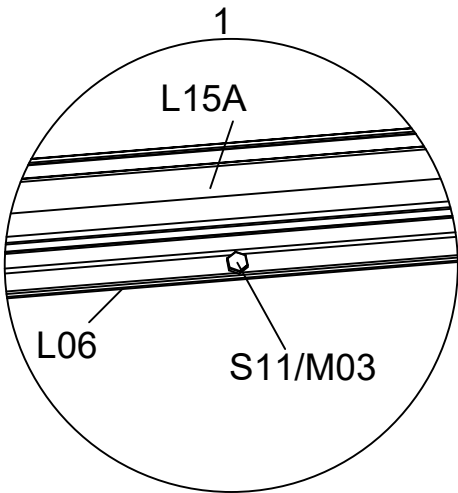
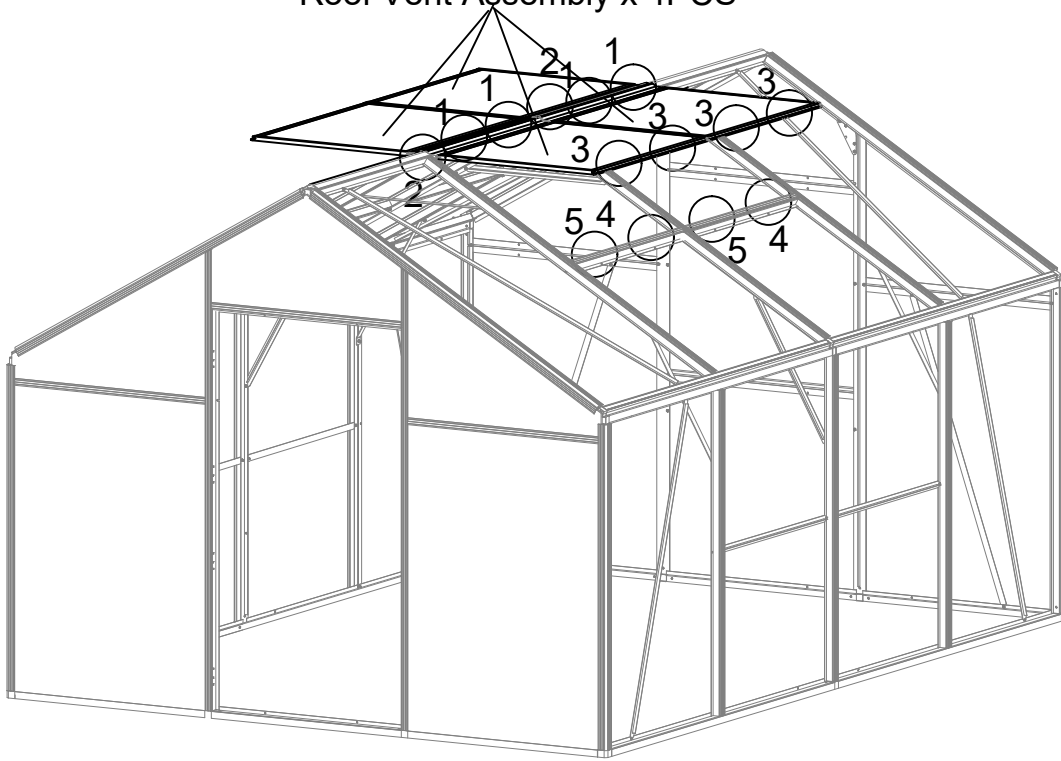

Roof Vent Assembly x 4PCS



PART	NO.	QTY.
	Y6	8
	Y7	4
	Y9	4

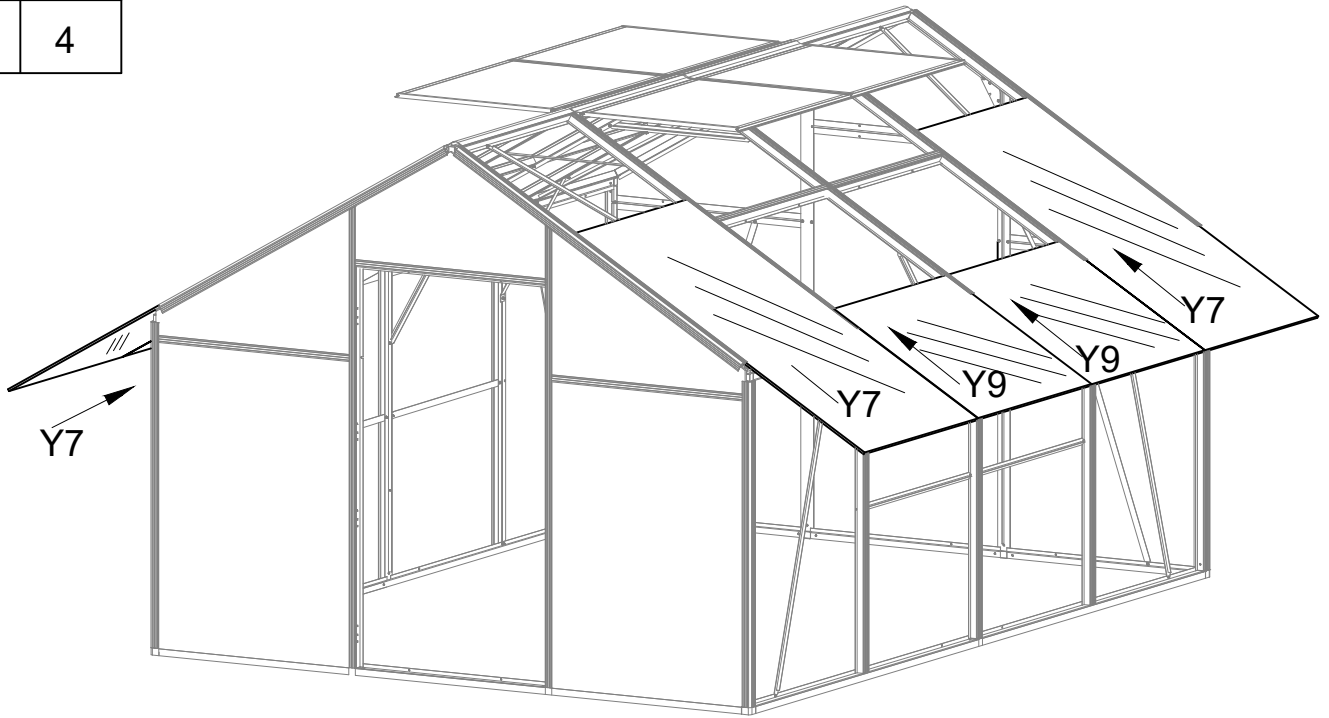





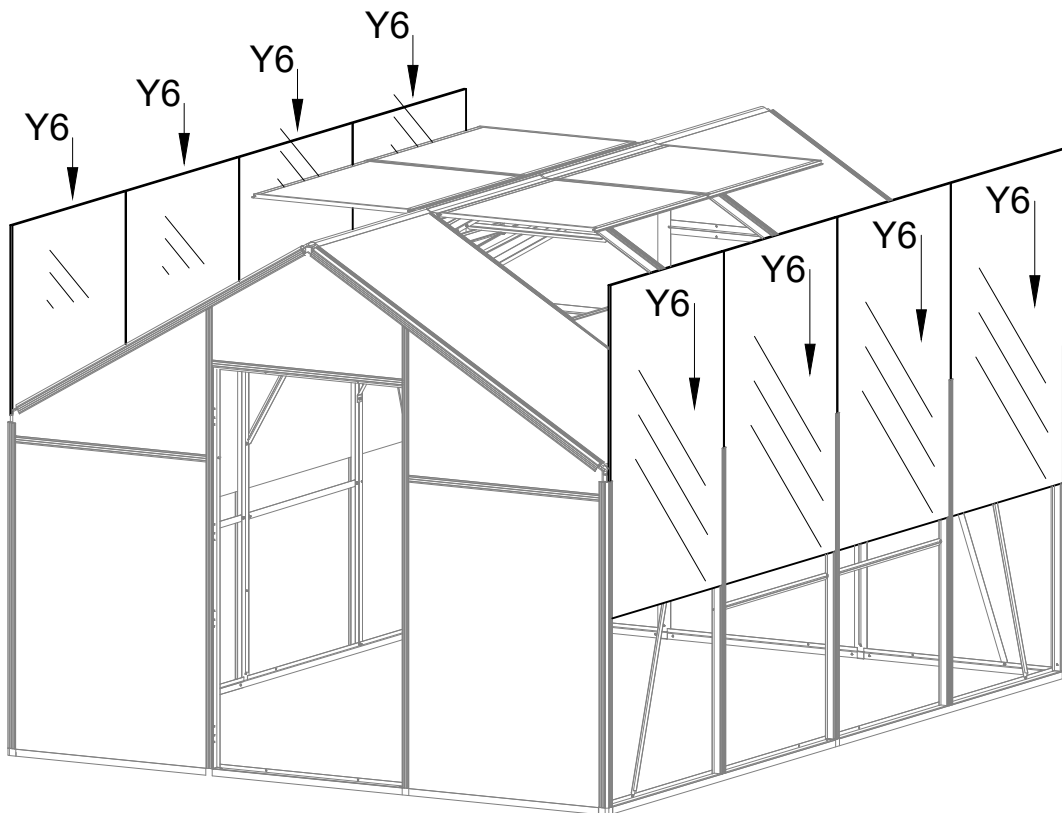

Insert all Y7 & Y9 panels into each roof of greenhouse.







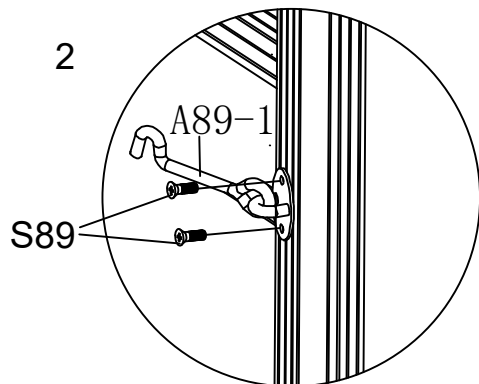
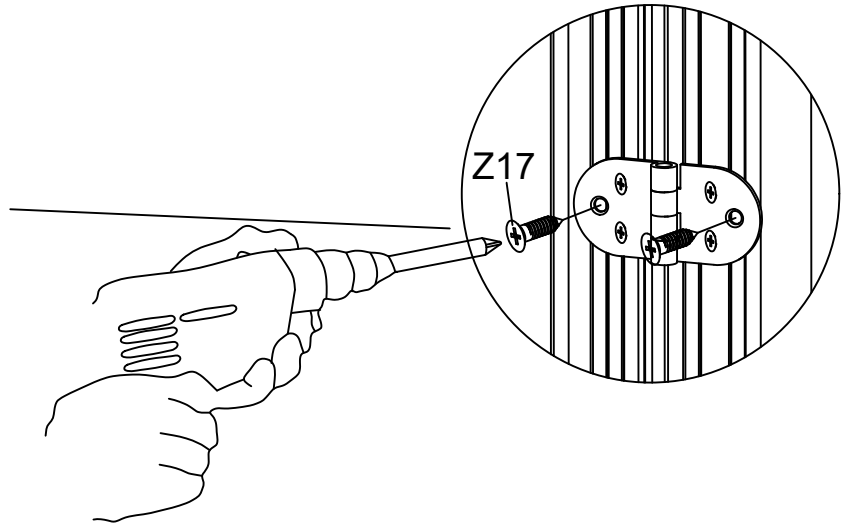
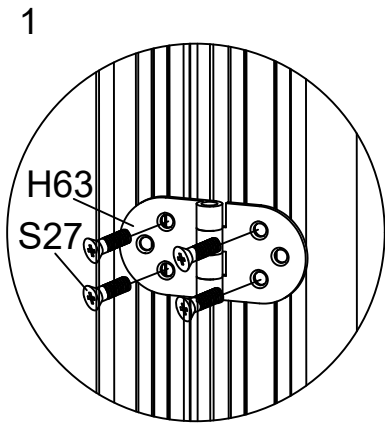
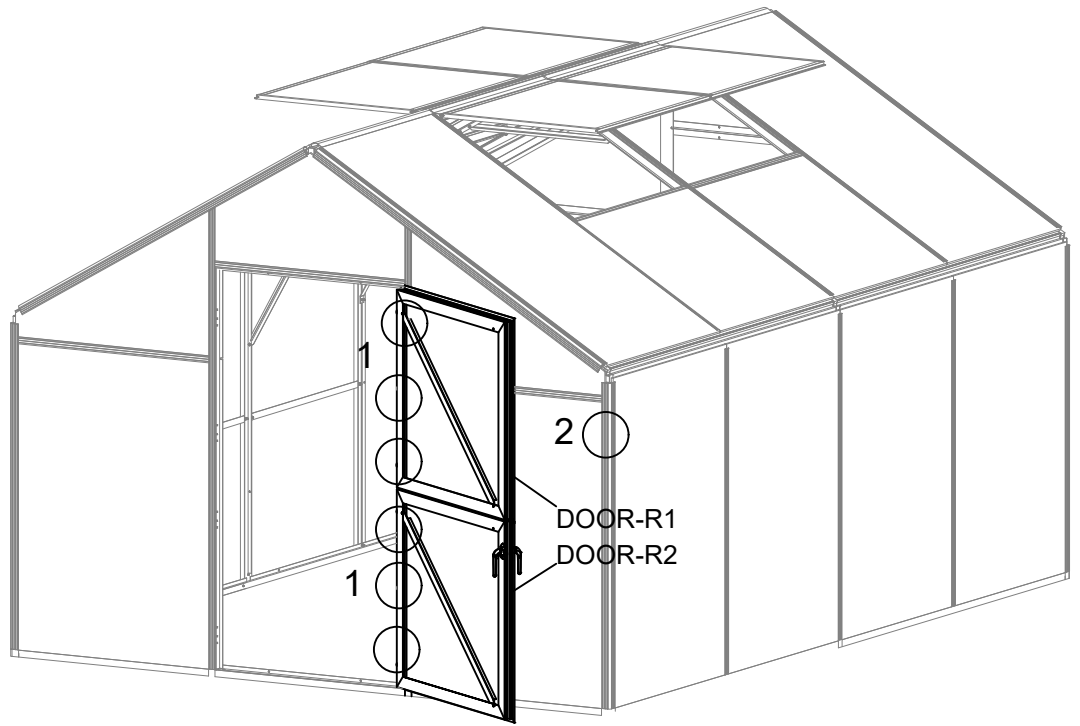

Note: If it is difficult sliding any panels in the channels, using soapy water or olive oil in the channels can reduce the friction.



Insert all Y6 panels into each side of greenhouse.

PART	NO	QTY
	H63	6
	A89-1	1
	Z17	12
	S27	
	M5X12	24
	S89	
	M3X12	2



PART	NO.	QTY.
	L09	4
	L30	4
	J02	2
	J06R/L	2/2
	J07	2
	J93	4
	J92	4
	Z10	16
	Ø5X30	
	Z02	12
	Ø4X16D	

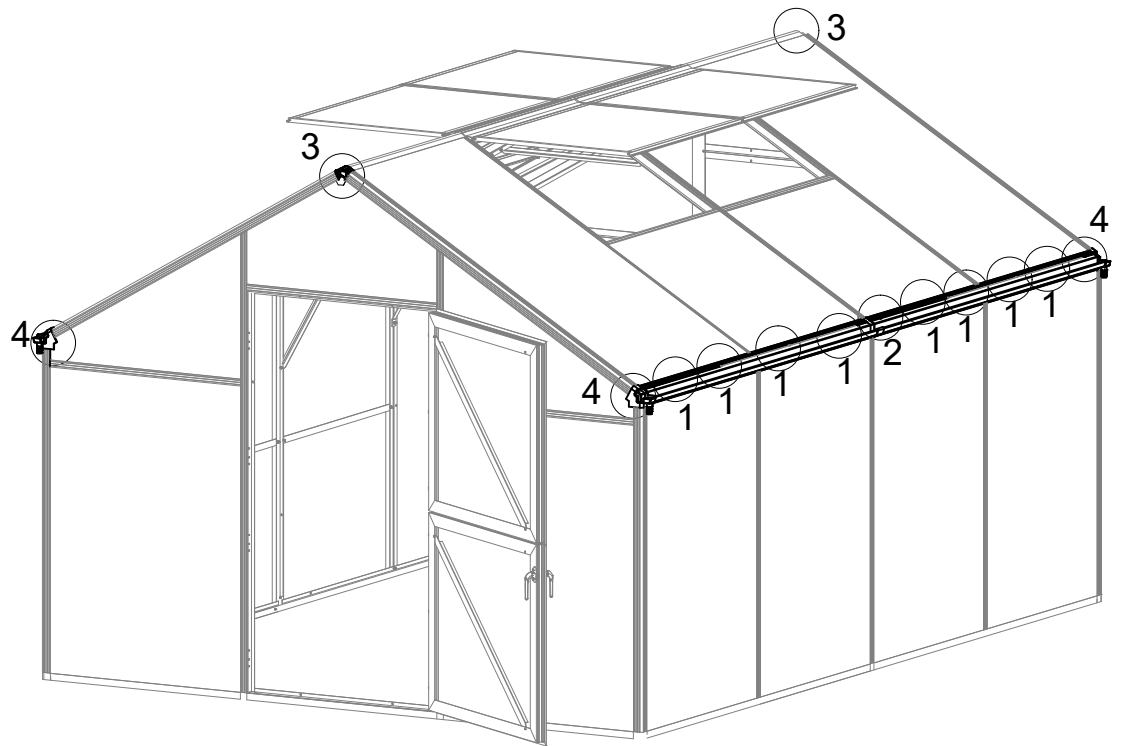

When installing the J07 and the second section of gutter, it can help if you have 2 people, one guiding the gutter into the J07 and the other gently tapping the end of the gutter with a rubber mallet. It can help to install the J07 into one end of the gutter before hand.

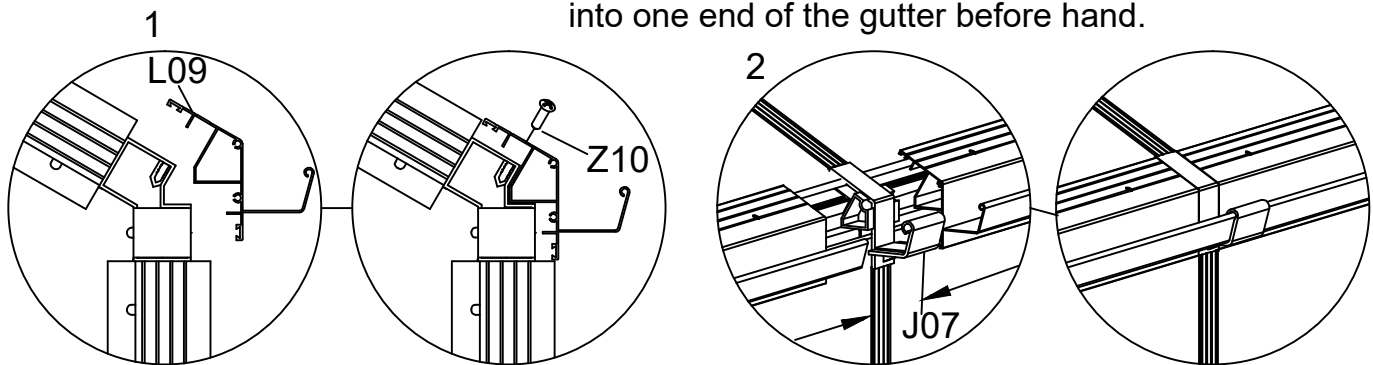

Install the L09 gutter profile over the edges of the panels, ensuring the rubber strip seals against the panels. Then fix into place with the Z10 screws, do not over tighten.

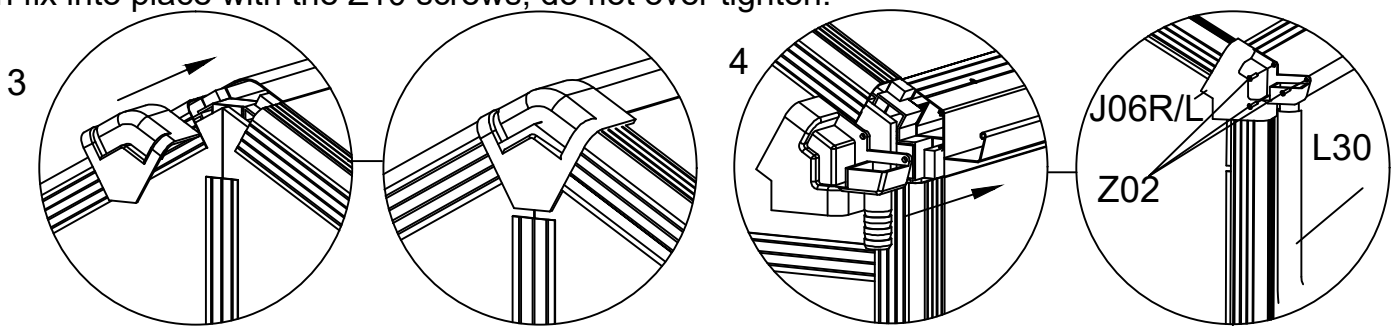

Drill one hole on both L01A & D approx 500mm up from the bottom, Dia. 2.5mm, then tighten J92 with Z02, and push L30 into the channel of J92 (see Fig. above).

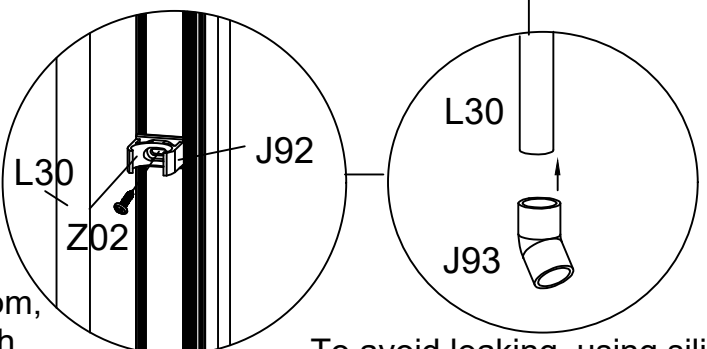

To avoid leaking, using silicone on J06R / L, L30 and J93 is an option (see Fig. above).

To avoid water leakage, we recommend applying silicone sealant to the junctions between the frame and poly panels and any gaps between the frame members (see highlighted areas in diagram below).

Note: Exterior grade clear silicone sealant is recommended and should be available at your local hardware store.

