

# GROW MORE Greenhouses

## Assembly Instructions

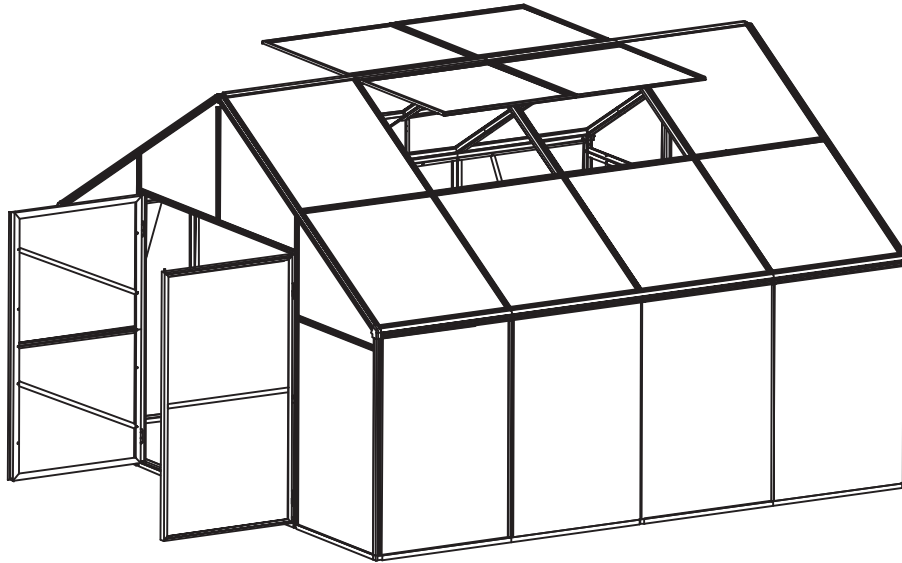

**MODEL: GM13D**

**GREENHOUSE SIZE: 13' 3 7/8"L x 13' 3 7/8"W x 8' 11 1/2"H**  
406cm L x 406cm W x 273cm H

**EXTENSION SIZE: 6' 6 3/4"L x 13' 3 7/8"W x 8' 11 1/2"H**  
200cm L x 406cm W x 273cm H

**PLEASE READ INSTRUCTIONS CAREFULLY BEFORE ASSEMBLY**

Item No.	Model No.	Packing List				
		AL No.1	AL No.2	AL No.3	PC No.1	PC No.2
2533210	GM13D	1CTN <input type="checkbox"/>	1CTN <input type="checkbox"/>	1CTN <input type="checkbox"/>	1CTN <input type="checkbox"/>	2CTNS <input type="checkbox"/>
2553250	GM13 ext			1CTN <input type="checkbox"/>		1CTN <input type="checkbox"/>



**Customer Support**

[Support@ACFgreenhouses.com](mailto:Support@ACFgreenhouses.com)

1-888-888-9050

# CONTENTS

1. Assembly Advice .....	Page 1
2. Product Features .....	Page 1 - 2
3. Parts List .....	Page 3 - 6
4. Base Assembly .....	Page 7 - 10
5. Door Assembly .....	Page 11 - 13
6. Roof Vent Assembly .....	Page 14
7. Framework & Panel Assembly .....	Page 15-32

## Assembly and Maintenance Advice

1. For safety purposes, we strongly recommend that this product is assembled by at least two people.
2. Some components have sharp metal edges. Please be careful when handling metal components. Please wear gloves, shoes and safety goggles during assembly.
3. Lay all of the components on a soft carpet or blanket to avoid any scratches or damages.
4. DO NOT climb or stand on the roof. Heavy articles should not be leaned against the greenhouse.
5. Keep the roof and gutter clear of snow, dirt & leaves. Allowing snow to build up on the roof may damage the product.
6. Unlike steel, if the paint finish is scratched this will not harm the aluminium underneath.
7. When your product needs cleaning, use a mild detergent solution and rinse with cold clean water. Do not use acetone, abrasive cleaners or strong detergents to clean the panels.

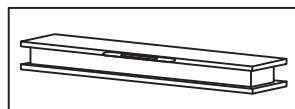
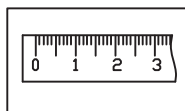
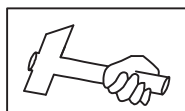
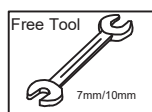

## Functions and Features:

1. Compared with traditional greenhouses this exciting product features many significant improvements. The hollow box profile aluminium framing is much stronger than other greenhouses and it can withstand much greater pressure.

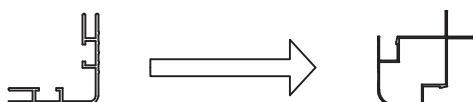

2. Easy and fast assembly.

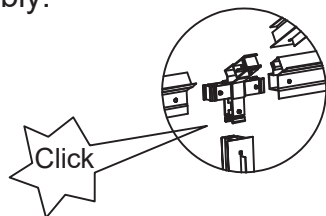

3. The strong two part eaves beam includes an integral gutter. Downpipes are also included as standard so you can collect rainwater.

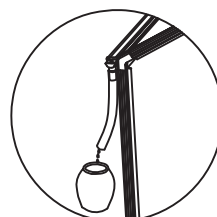

5. A steel base is not required as the aluminium base frame is fixed to the necessary concrete footings with the expansion bolts provided, alternatively you can easily secure it to a timber base with timber screws(not provided).

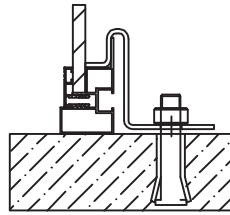

Expansion screw / Concrete ground

6. The Grange Series greenhouses come standard with Manual opening arms. Automatic openers can be purchased seperately and fitted to any window vent. We recommend two automatic vent openers be fitted to each vent in the same positions the standard manual vent arms.

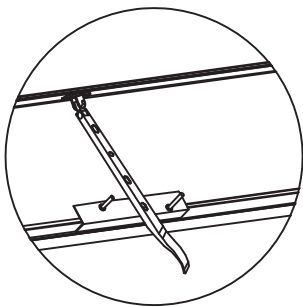

Manual opener

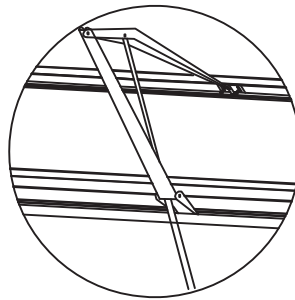





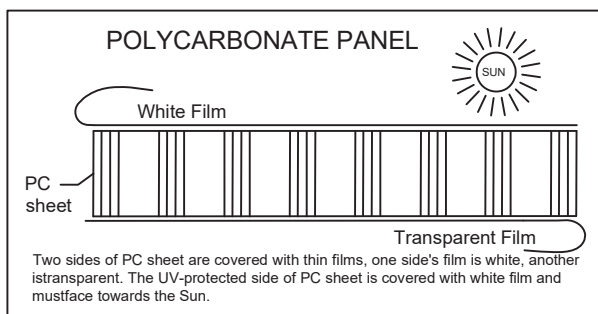



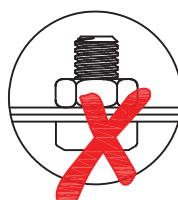
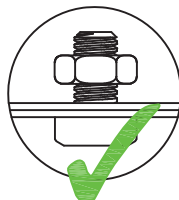













Automatic opener





















7. Please ensure the roof vents are not installed into the end roof bays of the greenhouse as this is where you need the bracing.
8. Each Polycarbonate Panel comes with UV protected properties. Please ensure the clear film with the text faces out, toward the sun Remove both films before installation of the panels.



















9. Nuts not to be tightened before the end of assembly! Unless otherwise stated, do not tighten the bolts/nuts/screws until the shed is finally erected!













PART	NO.	QTY.	
	L01D	2	
	L01E	2	
	L01B	2	
	L01C	2	
	L03E	2	
	L03F	2	
	L04A	2	
	L04B	4	
	L04C	2	
	L17	2	
	L05A	4	
	L05G	8	
	L05H	8	
	L08A	4	
	L08B	2	
	L18A	4	
	L18B	4	
	L18C	2	
		L16A	2
		L16B	2
		L16C	2
	L18D	2	
		L18F	2
	L18E	4	
	L30	4	









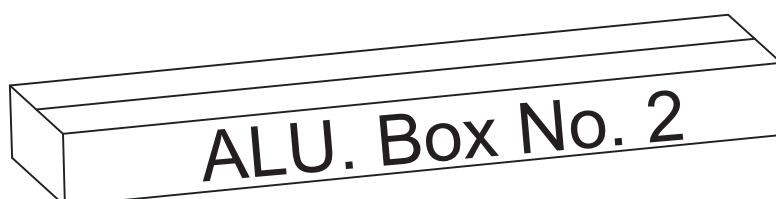













PART	NO.	QTY.
	A52	2
	A53	2
	A54	4
	A09	2
	A10	2
	A11	2
	A14	24
	D17	6
	D04	2
	S05	86
	M6X12	
	M03	86
	M6	
	D07	4
	S08	4
	M8X60	
	Z02	12
	Ø4X16D	
	Z09	48
	Ø5X15	
	J01R/L	2 /2
	J03	4
	J02	2
	J06R/L	2 /2
	J92	4
	J93	4











ALU. Box No. 1









	PART	NO.	QTY.
1		L02A	2
2		L02B	2
3		L04B	2
4		L05B	2
		L05C	2
		L05D	2
5		L06	1
6		L07	2
7		L08B	2
8		L09	2
9		L15A	2
10		L19	4
		L20	2
		L21	2
11		L04E	2
12		L22	3

PART	NO.	QTY.
	A01	4
	A69	2
	A70	2
	S05	42
	M6X12	
	S11	4
	M6X20	
	M03	46
	M6	
	Z02	12
	Ø4X16D	
	Z10	6
	Ø5X30	
	Z04	8
	Ø4X8	
	D07	4
	S08	4
	M8X60	



	PART	NO.	QTY.
1		L02A	2
2		L02B	2
3		L04B	2
4		L05B	2
		L05C	2
		L05D	2
5		L06	1
6		L07	2
7		L08B	2
8		L09	2
9		L15A	2
10		L19	4
		L20	2
		L21	2
11		L04E	2
12		L22	3
13		L03A	2
14		L03B	2
15		L03K	2
16		L08A	2
17		L05E	2
		L05F	4

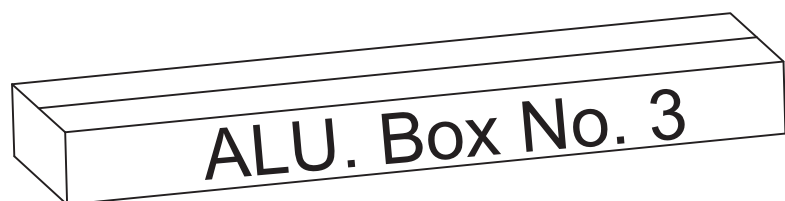

PART	NO.	QTY.
	A01	4
	A69	2
	A70	2
	S05	56
	M6X12	
	S11	4
	M6X20	
	M03	60
	M6	
	Z02	12
	Ø4X16D	
	Z10	6
	Ø5X30	
	Z04	16
	Ø4X8	
	D07	6
	S08	6
	M8X60	

PART	NO.	QTY.
	D17	2
	A12	2
	A13	1
	A15	2
	A16	2
	J03	2
	J04	1
	J07	2







# PC Box No. 1





## Door Assembly

PART	NO.	QTY.
	Y11	4
	Y12	4

## Front Wall Assembly

PART	NO.	QTY.
	Y1	1
	Y2	2
	Y4	1
	Y5	1
	Y13	1

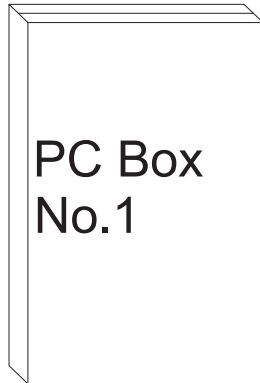

## Back Wall Assembly

PART	NO.	QTY.
	Y1	1
	Y2	2
	Y4	1
	Y5	1
	Y13	1



# PC Box No. 2

## 2 Sections Assembly

PART	NO.	QTY.
	Y6	4
	Y7	6
	Y10	2

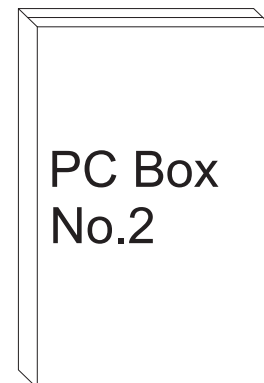



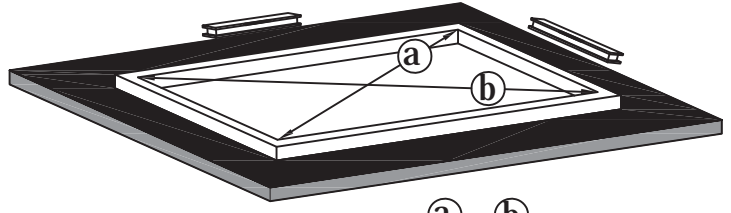
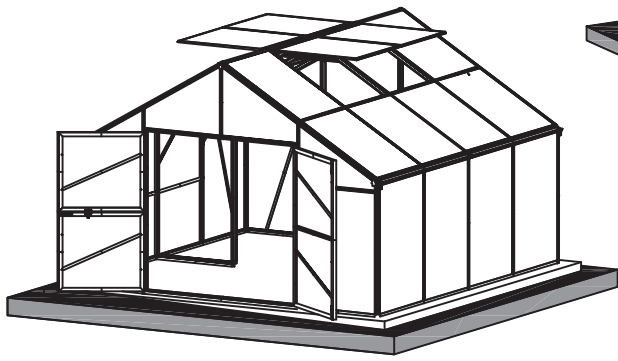

a = b

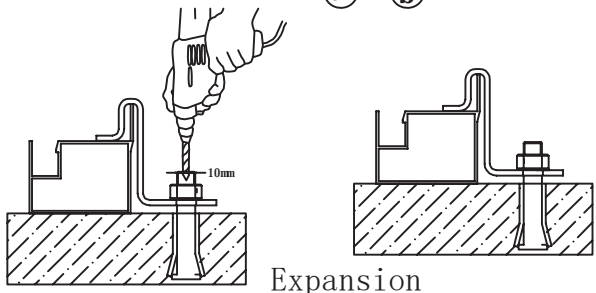

Expansion screw/Concrete ground

It is essential the dimensions a + b are the same to ensure the base is square.

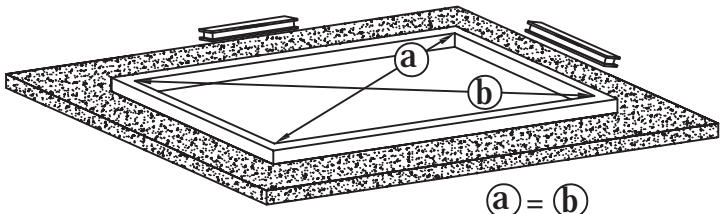
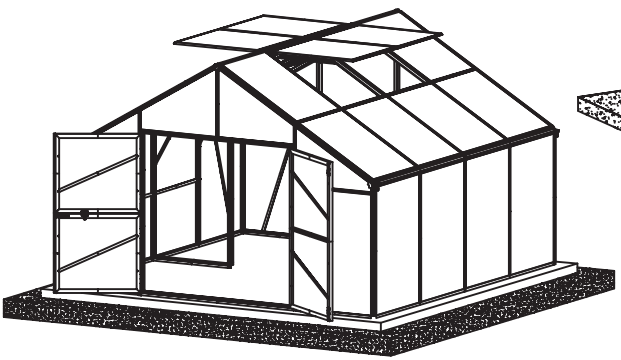

a = b

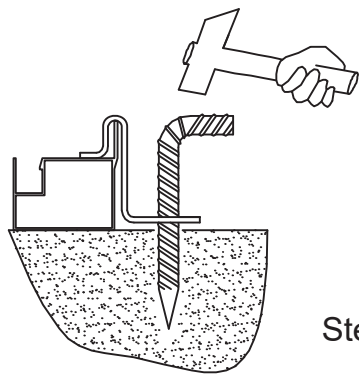

Steel pegs in soil

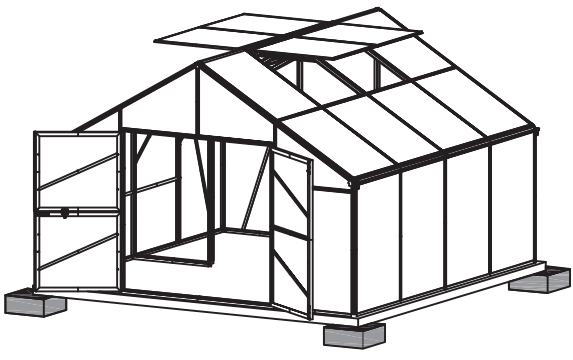

Support at the corners only is inadequate.

# GM13D

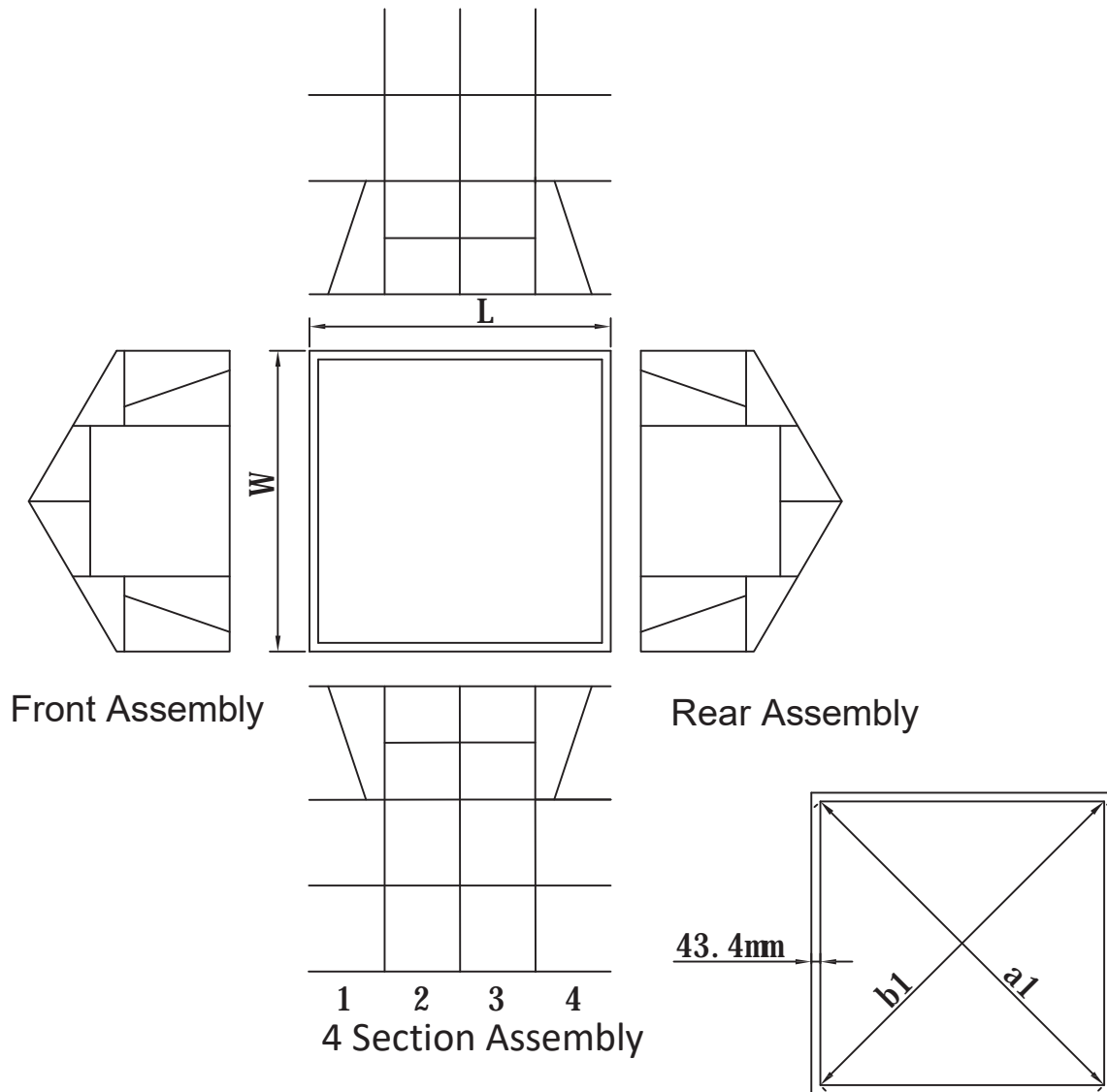

Dim/Model	GM 3D	GM 3D+Ext (1)	GM 3D+Ext (2)	GM 3D+Ext (3)	GM 3D+Ext (4)	GM 3D+Ext (5)	etc.
W (mm)	4059.4	4059.4	4059.4	4059.4	4059.4	4059.4	
L (mm)	4059.4	6061.6	8063.8	10066	12068.2	14070.4	
a=b (mm)	5740.9	7295.3	9027.9	10853.7	12732.7	14644.3	
a1=b1 (mm)	5615.3	7172.3	8909	10738.5	12620.6	14534.8	

- \* W= Outer Width of Base Profiles
- \* L= Outer Length of Base Profiles
- \* a=b= Outer Diagonal of Base Profiles
- \* a1=b1= Inner Diagonal of Base Profiles



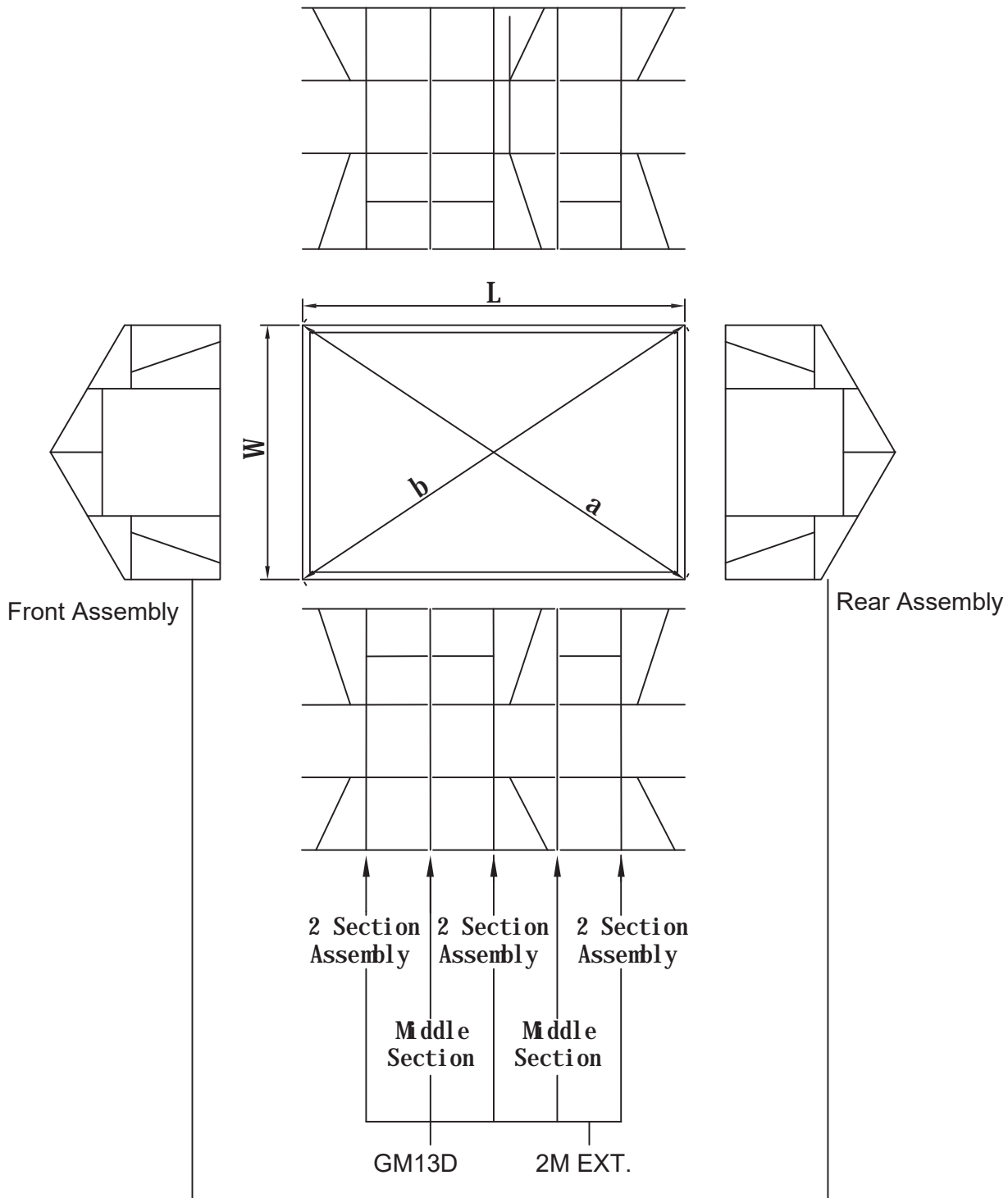



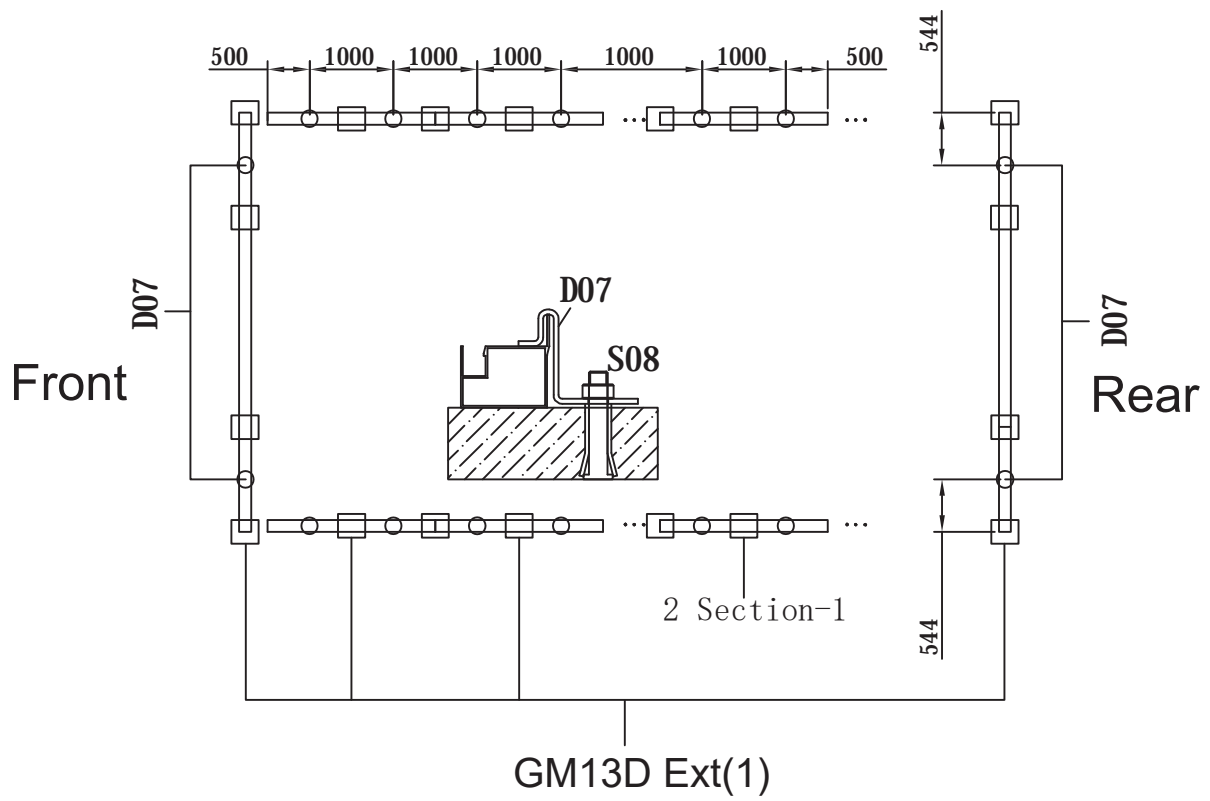



# GM13D + Ext(1)



\* The basic model, GM13D, can be easily extended by adding a '2 Section Assembly' each time for a longer size.



\* This shows a layout for W05's positions where it is placed in the middle of PC panel for each section.

PART	NO.	QTY.
	L18A	1
	L18B	1
	L18C	1
	L16C	1
	L05G	2
	Y11	1
	A14	4
	Z09	8
	Ø5X15	
	S05	4
	M6X12	
	M03	4
	M6	

### Door 1 Assembly

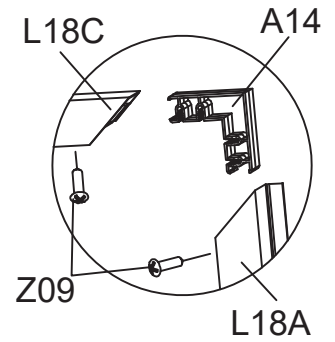
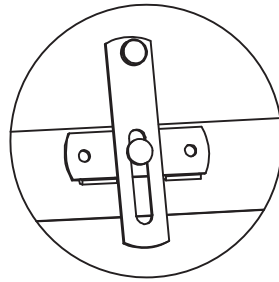
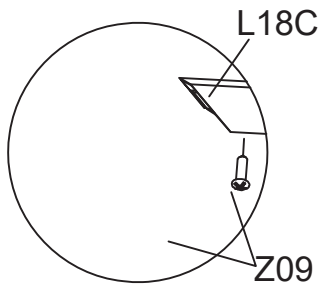
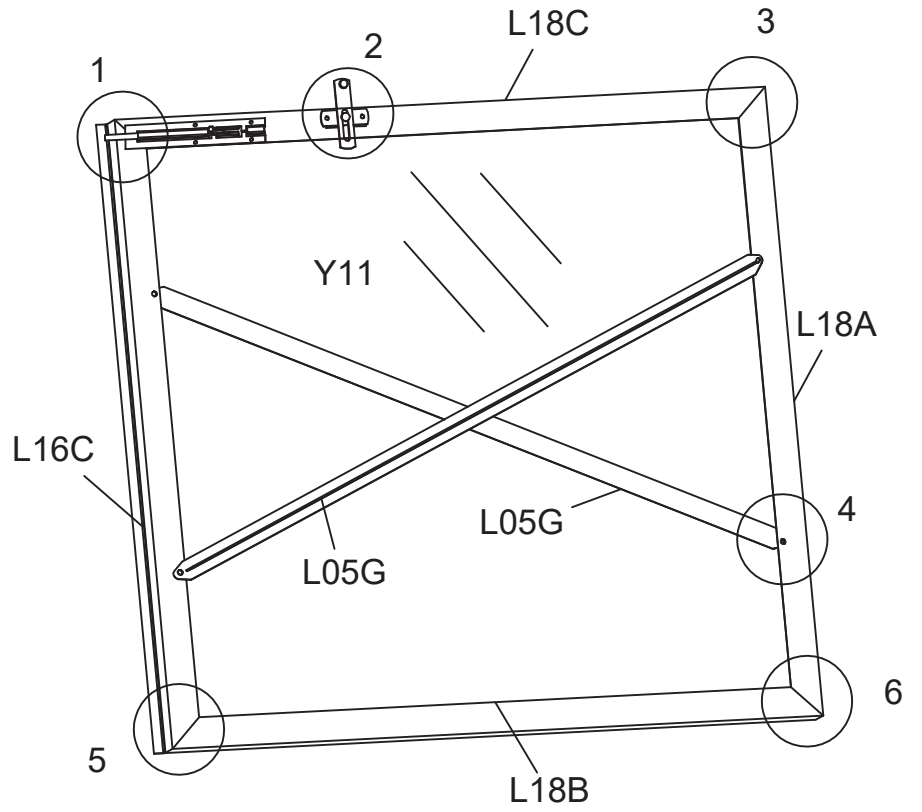







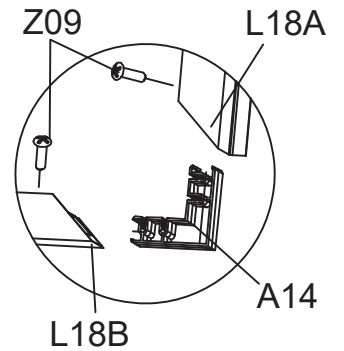
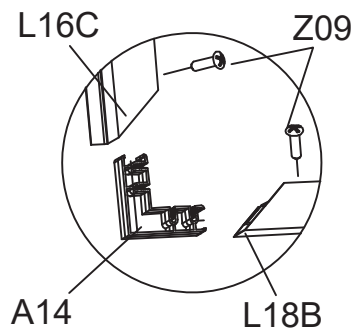
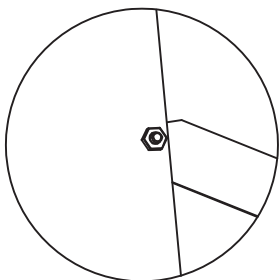



4

5









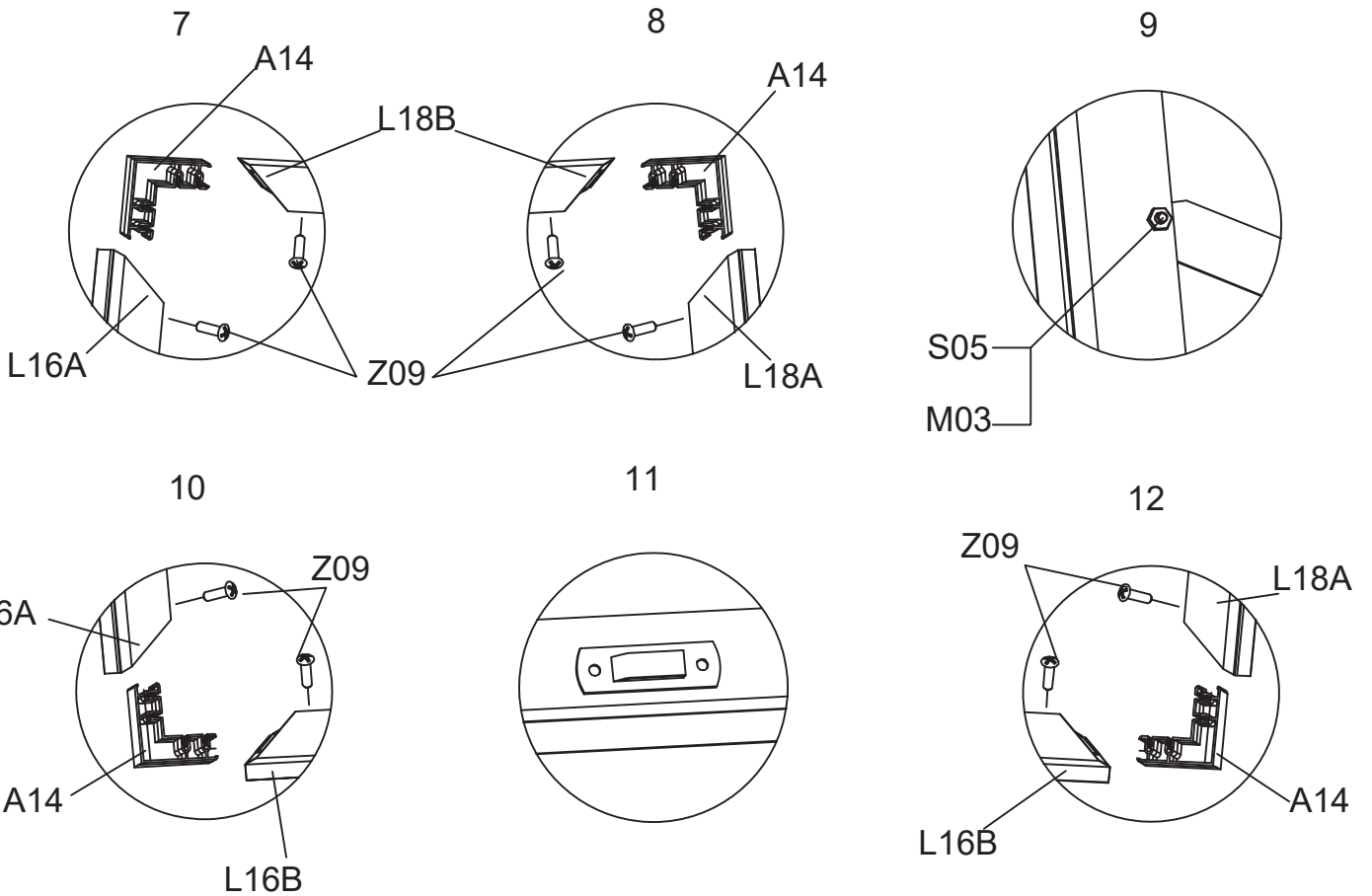
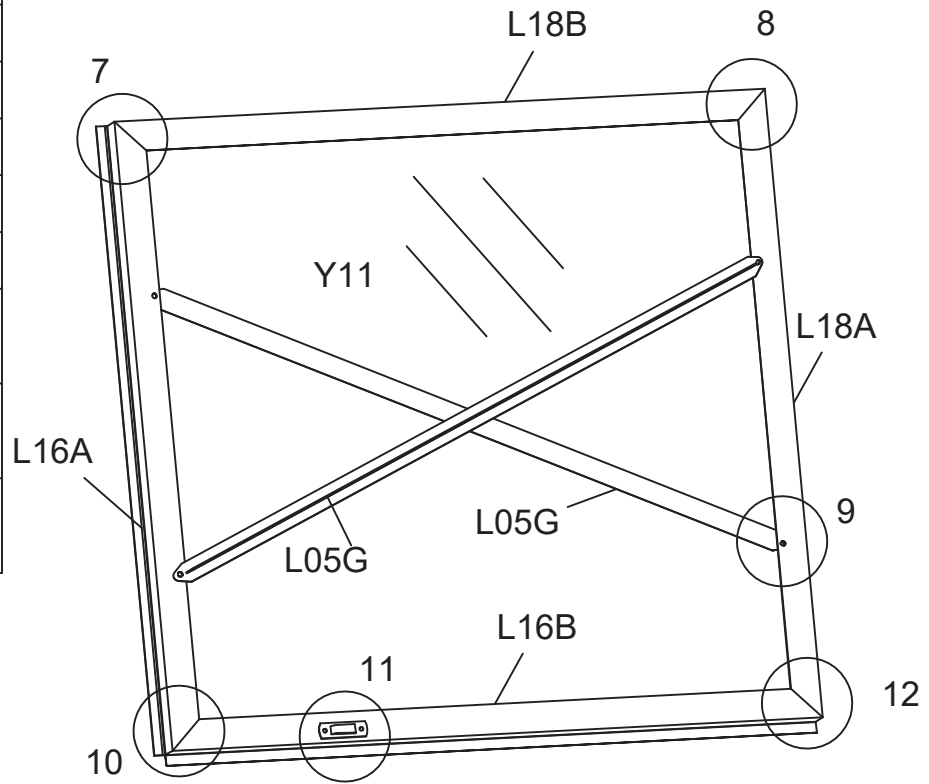

6



PART	NO.	QTY.
	L18A	1
	L18B	1
	L16A	1
	L16B	1
	L05G	2
	Y11	1
	A14	4
	Z09	8
	Ø5X15	
	S05	4
	M6X12	
	M03	4
	M6	









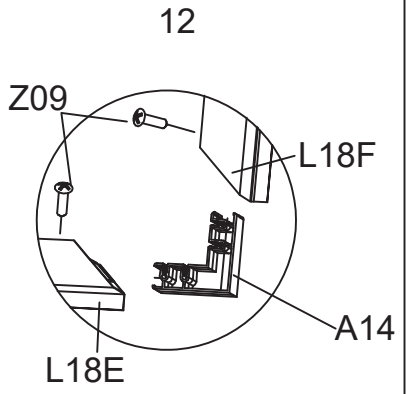
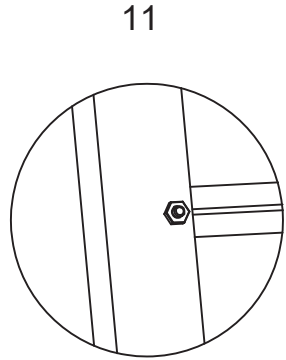
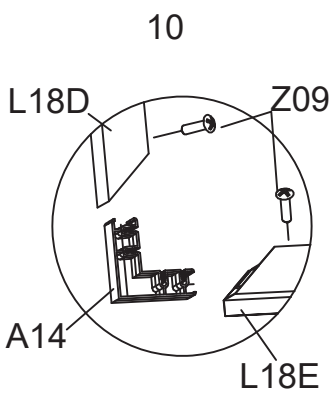
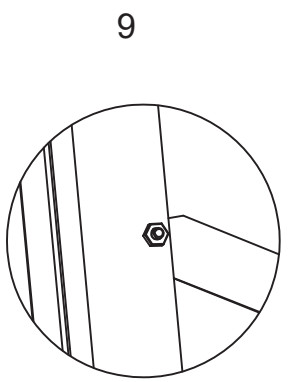
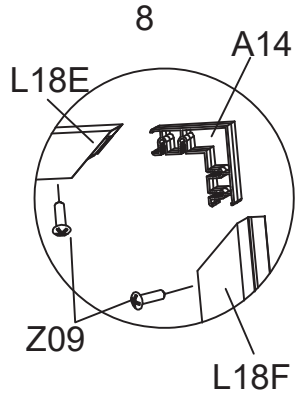
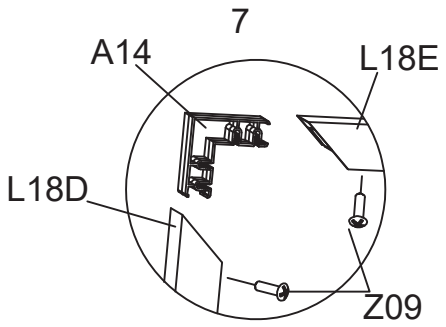
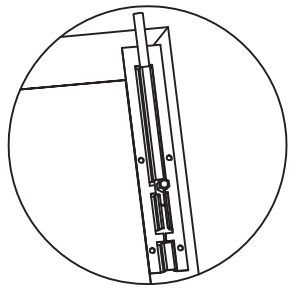
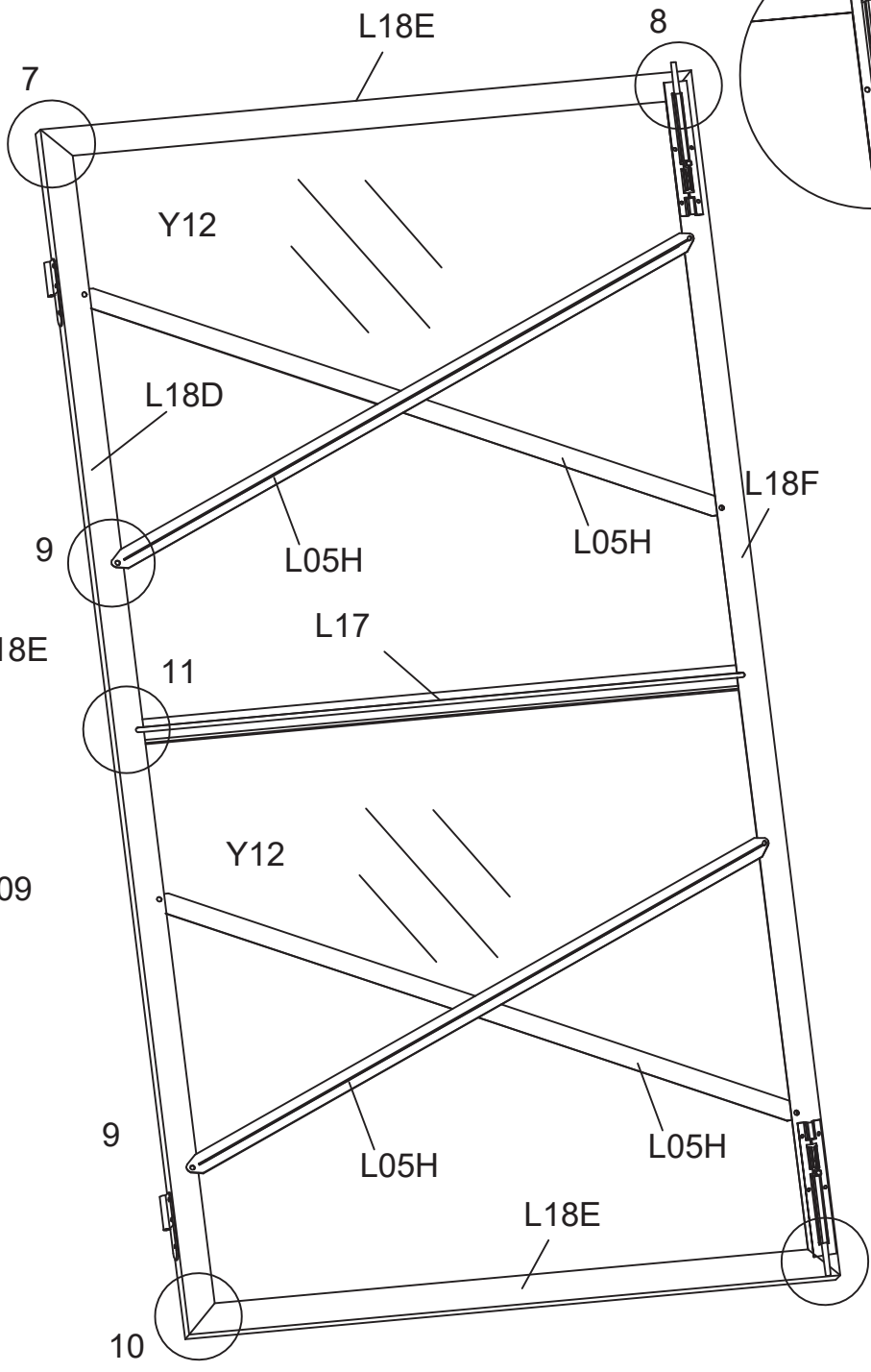

### Door 2 Assembly



PART	NO.	QTY.
	L18D	1
	L18E	2
	L18F	1
	L17	1
	L05H	4
	Y12	2
	A14	4
	Z09	8
	Ø5X15	
	S05	10
	M6X12	
	M03	10
	M6	

### Door 3 Assembly







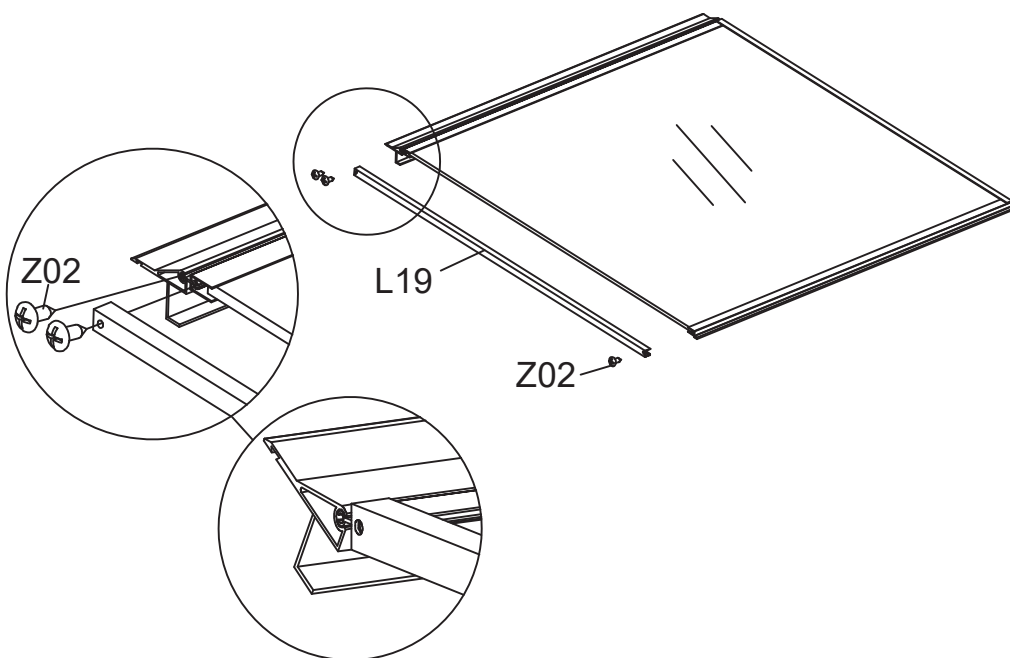
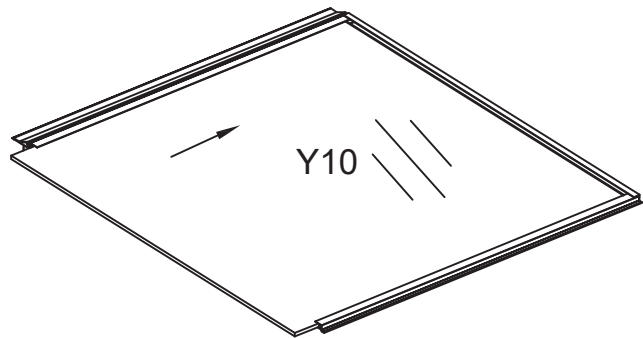
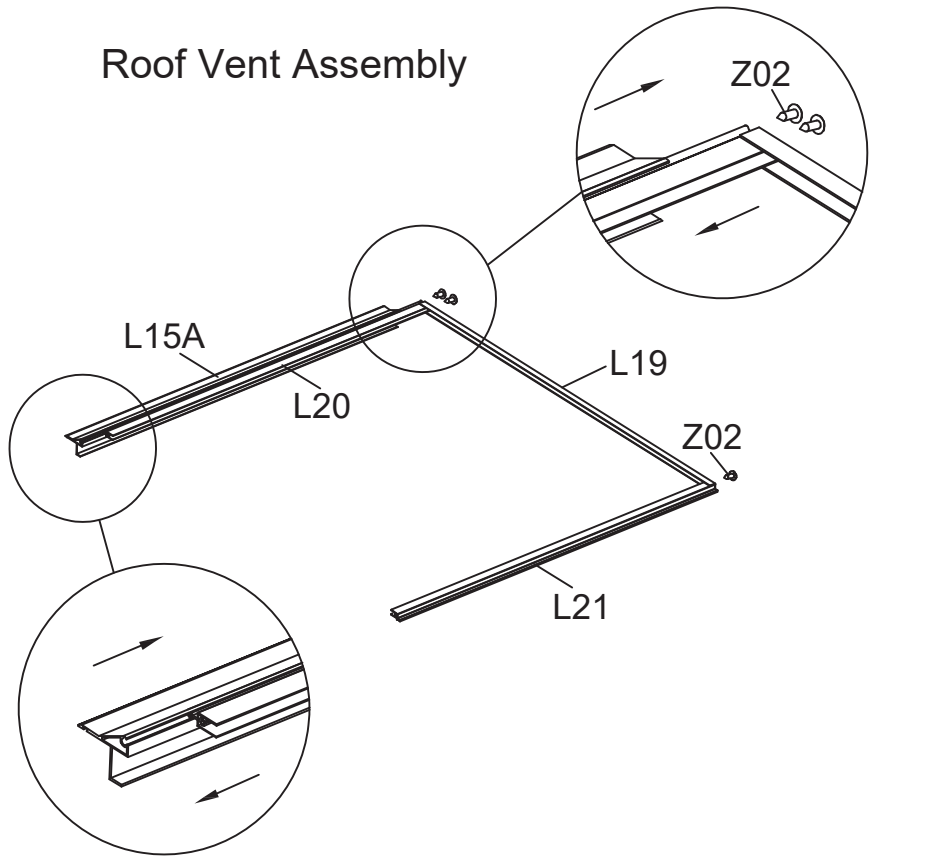



PART	NO.	QTY.
	L15A	1
	L19	2
	L20	1
	L21	1
	A01	2
	S11 M6X20	2
	M03 M6	2
	Z02 Ø4X16D	6
	Z04 Ø4X8	4
	Y10	1

### Roof Vent Assembly





PART	NO.	QTY.
	L08A	4
	L08B	6
	A52	2
	A53	2
	A54	4
	A16	2
	J01R/L	2/2
	J03	6

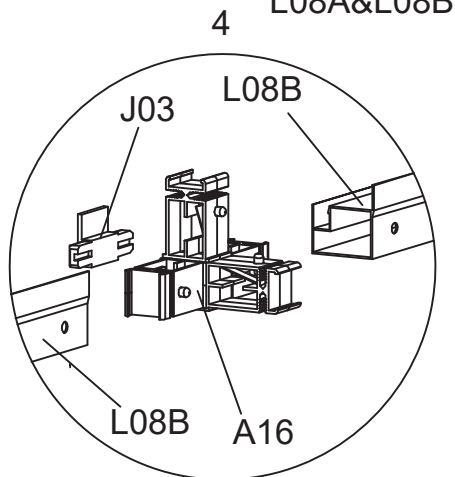
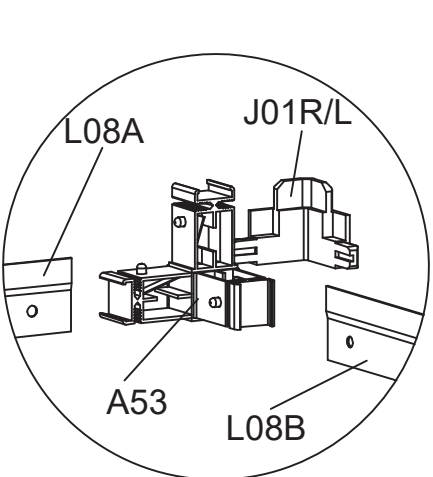
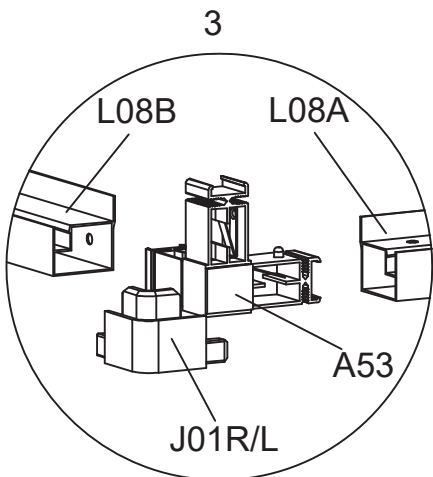
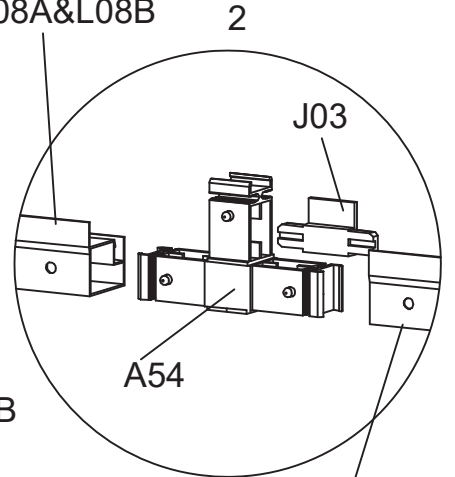
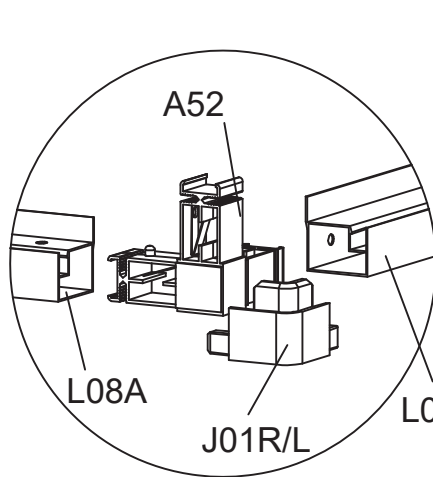
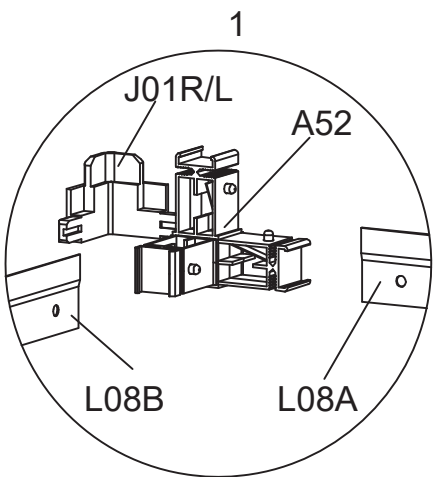
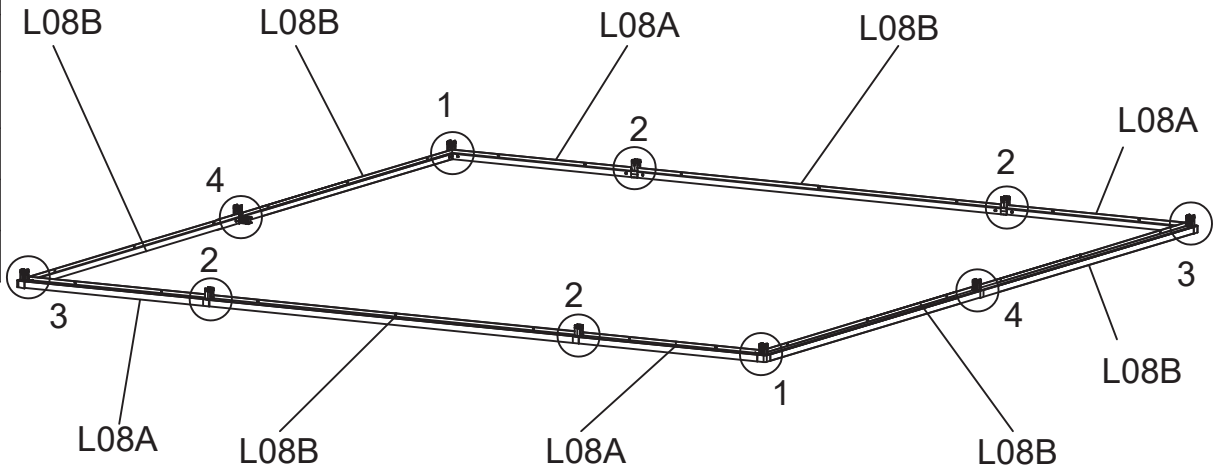



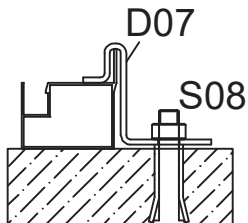

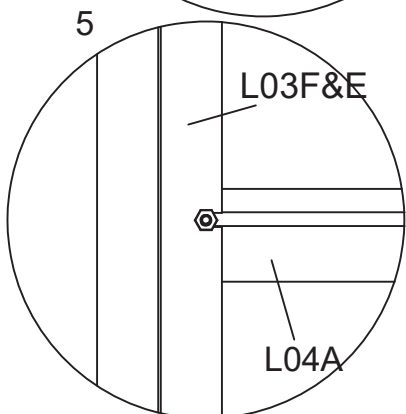
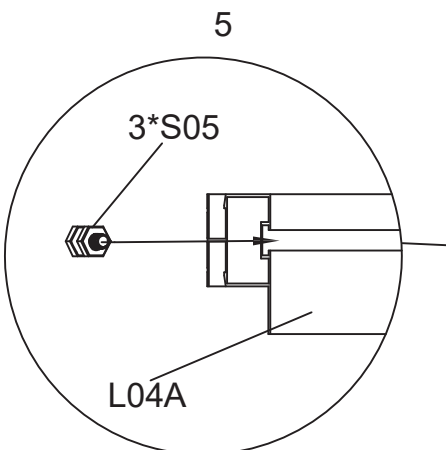
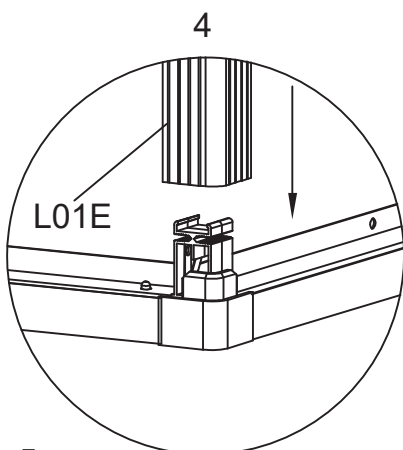
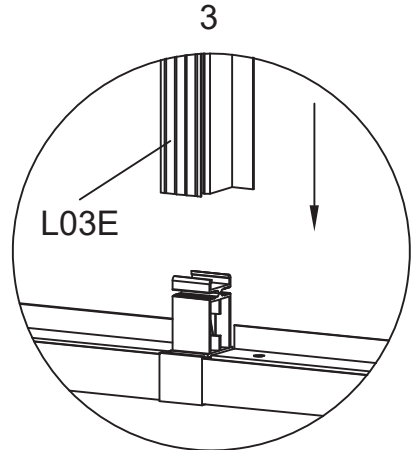
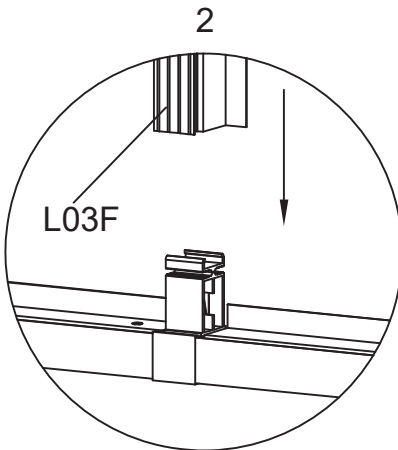
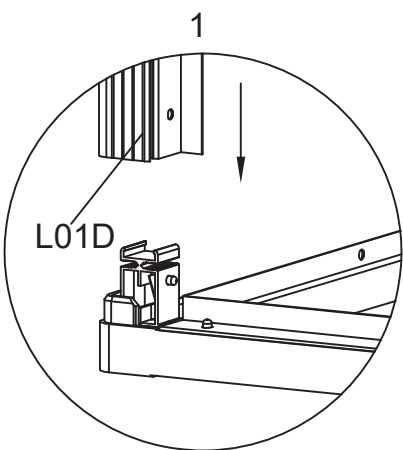
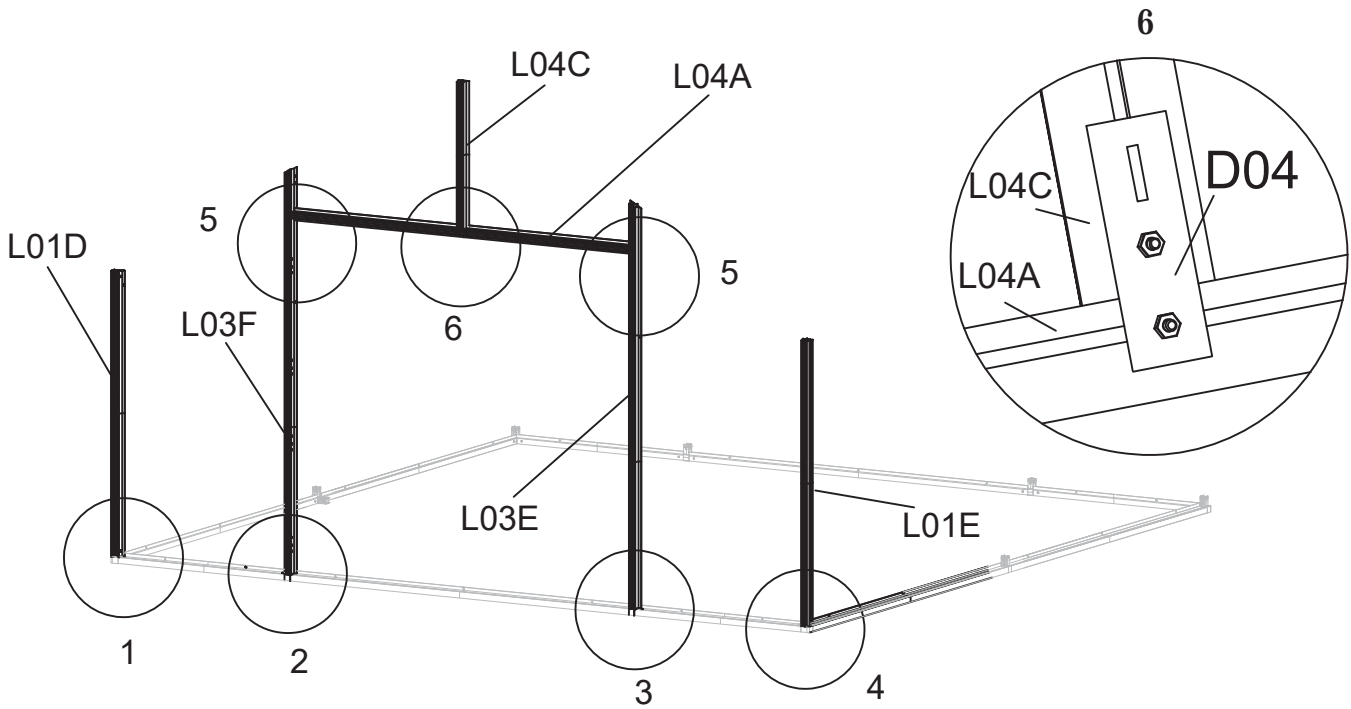









Assemble all D07 followed by previous Page 15 after each base profile is connected.





Slide 3\*S05 into L04A, and tighten L04A at each end with S05

PART	NO.	QTY.
	L01E	1
	L03E	1
	L03F	1
	L04A	1
	L04C	1
	D04	1
	S05	3
	M6X12	
	M03	3
	M6	

PART	NO.	QTY.
	L04B	2
	Y2	2
	Y4	2
	Y5	1
	Y13	1
	S05	4
	M6X12	
	M03	4
	M6	

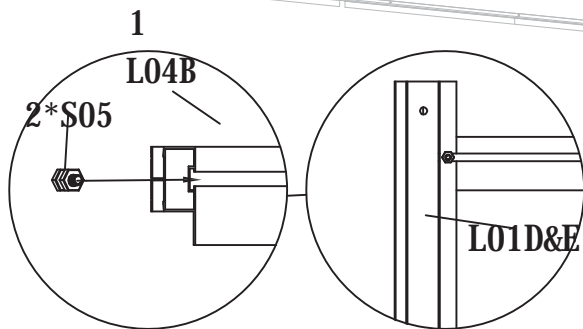
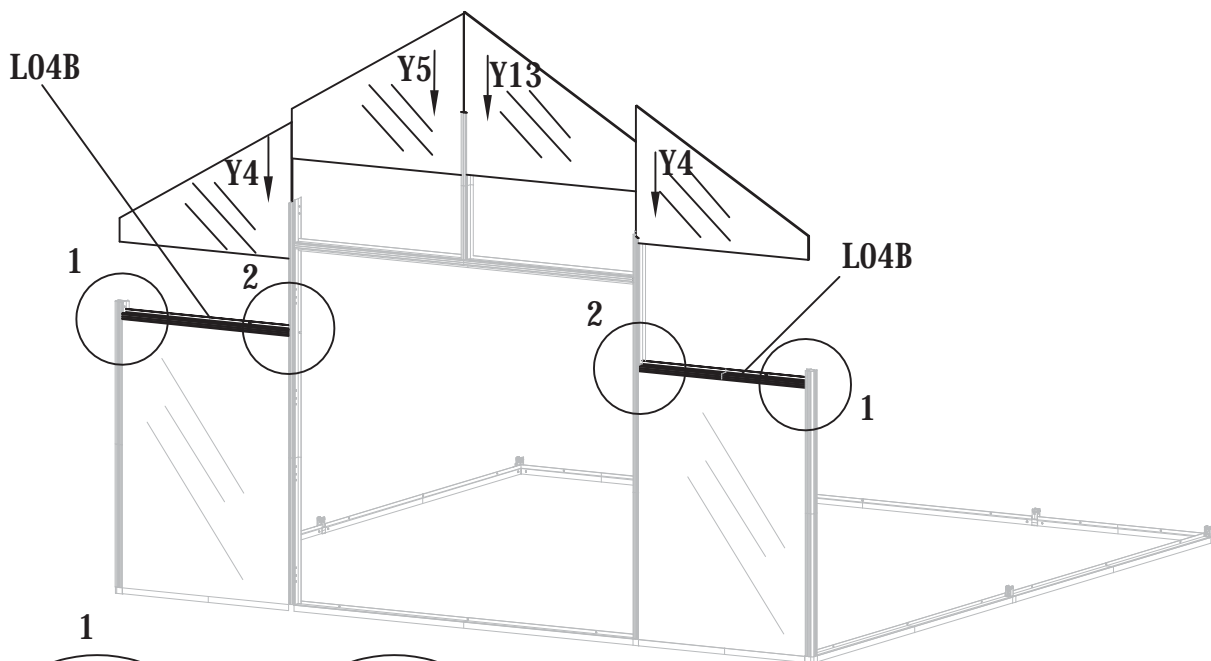
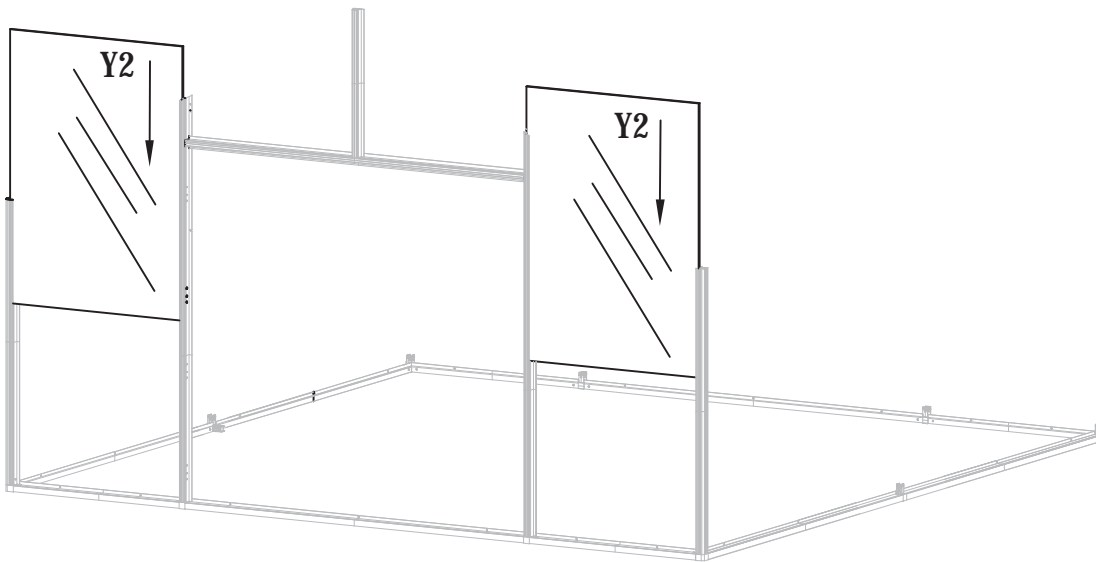

Slide 2\*S05 into L04B, and tighten L04B at each end with S05

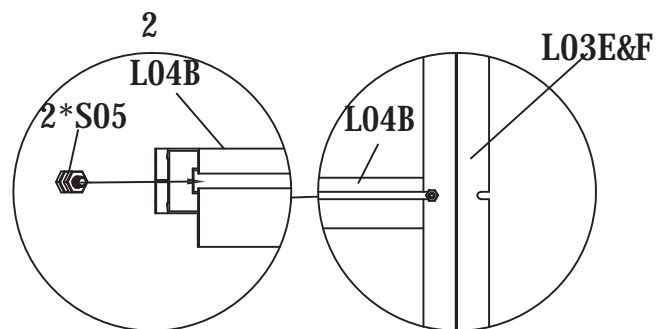

Slide 2\*S05 into L04B, and tighten L04B at each end with S05

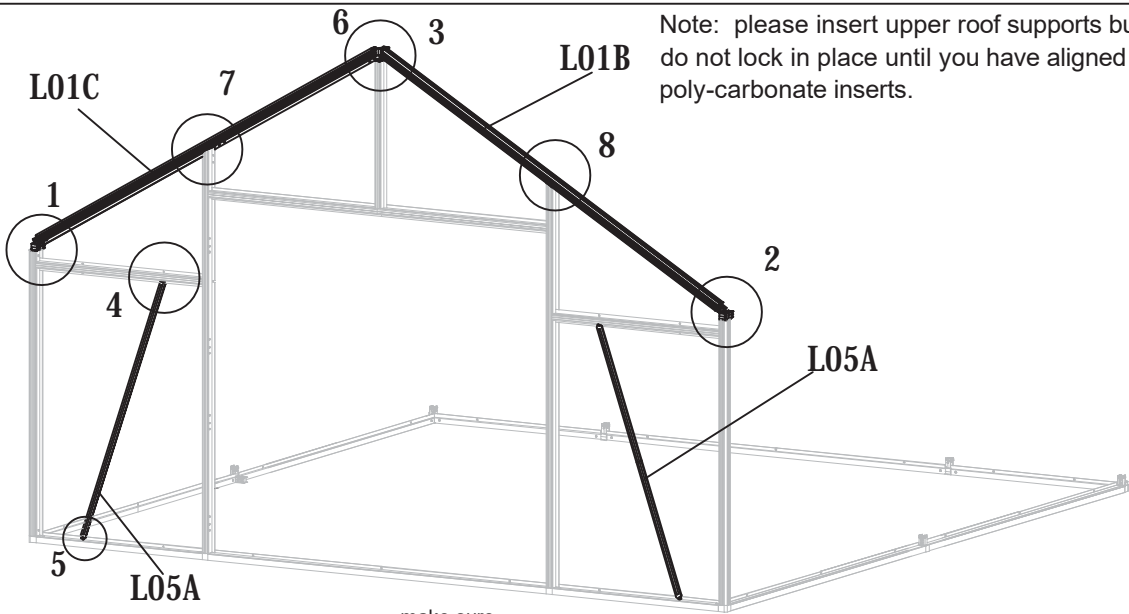







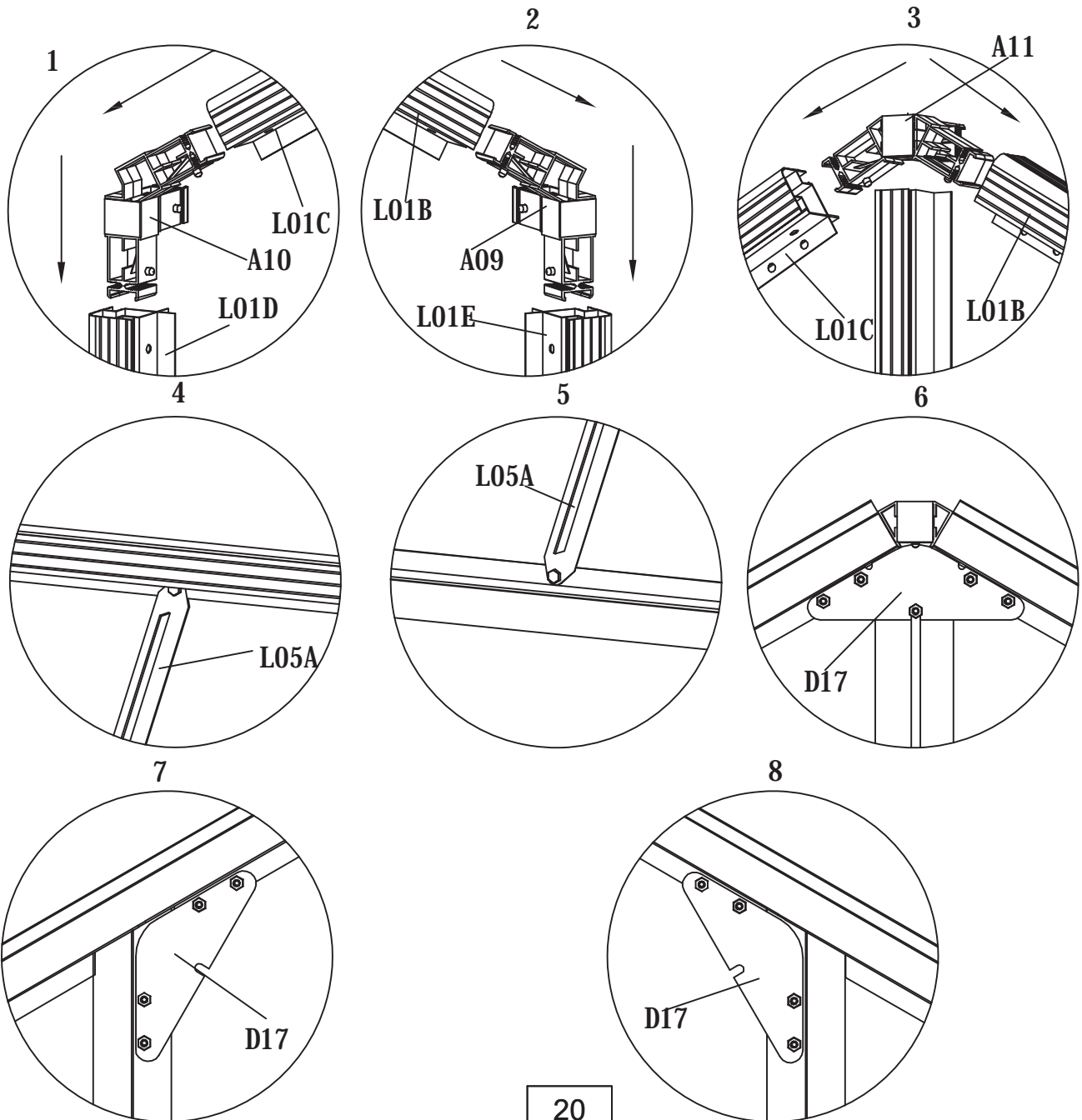

Note: please insert upper roof supports but, do not lock in place until you have aligned the poly-carbonate inserts.

PART	NO.	QTY.
	L01B	1
	L01C	1
	L05A	2
	A09	1
	A10	1
	A11	1
	D17	3
	S05	16
	M6X12	
	M03	16
	M6	

make sure you pay close attention to the direction of the pins



PART	NO.	QTY.
	L01D	1
	L01E	1
	L03E	1
	L03F	1
	L04A	1
	L04C	1
	D04	1
	S05	3
	M6X12	
	M03	3
	M6	

Slide 3\*S05 into L04A, and tighten L04A at each end with S05

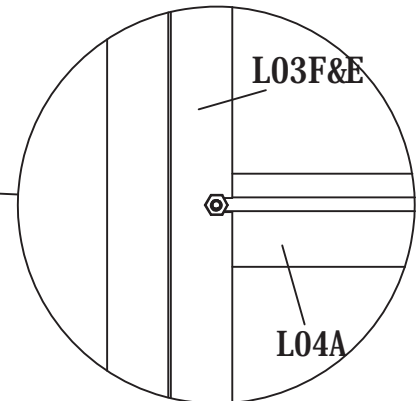
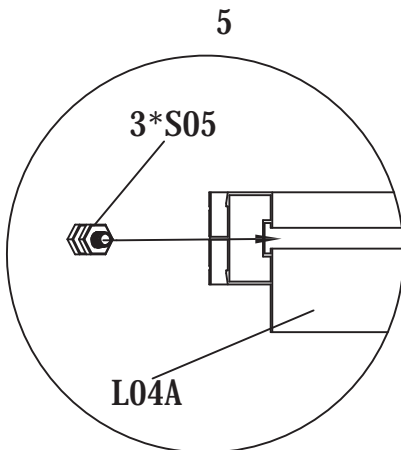
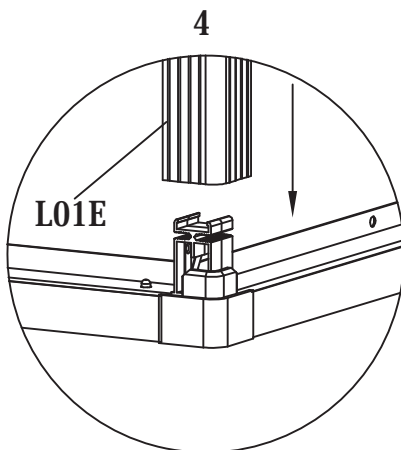
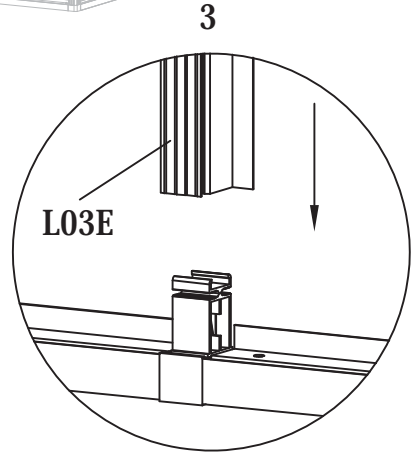
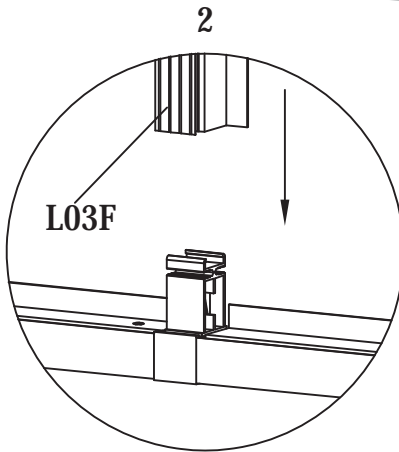
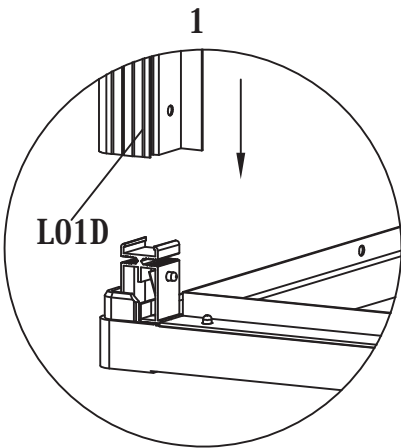
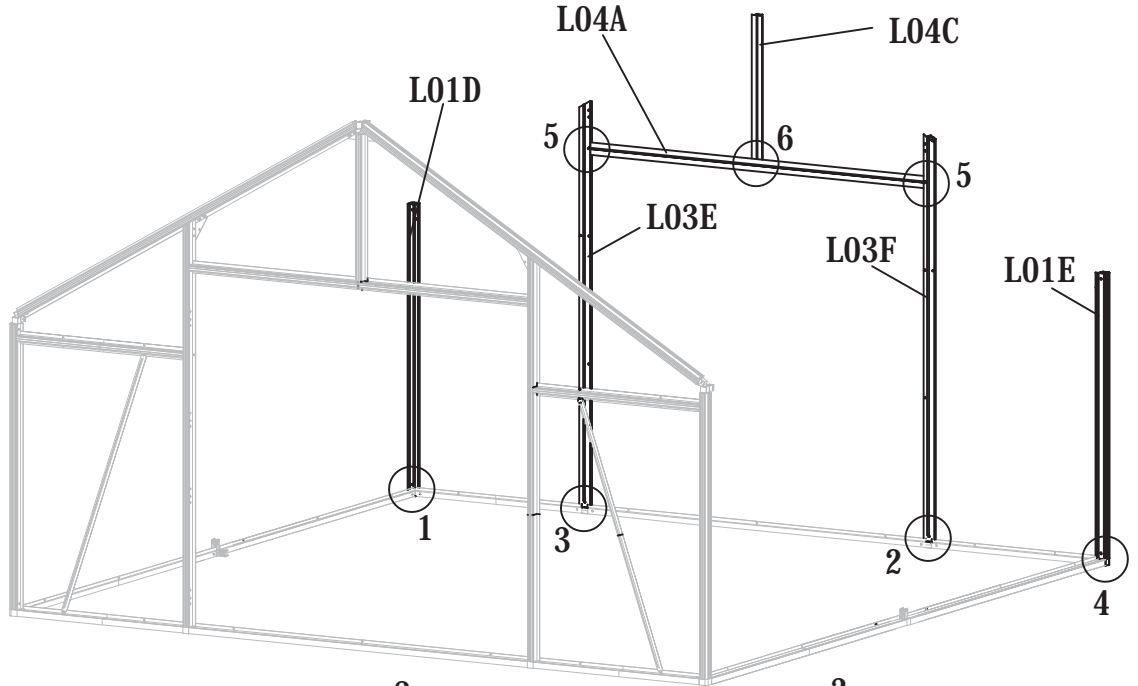
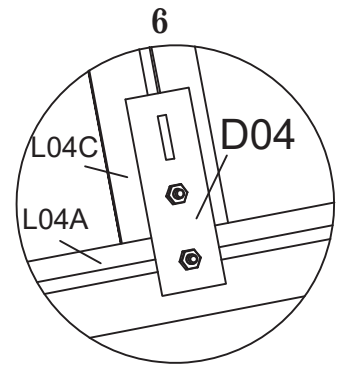

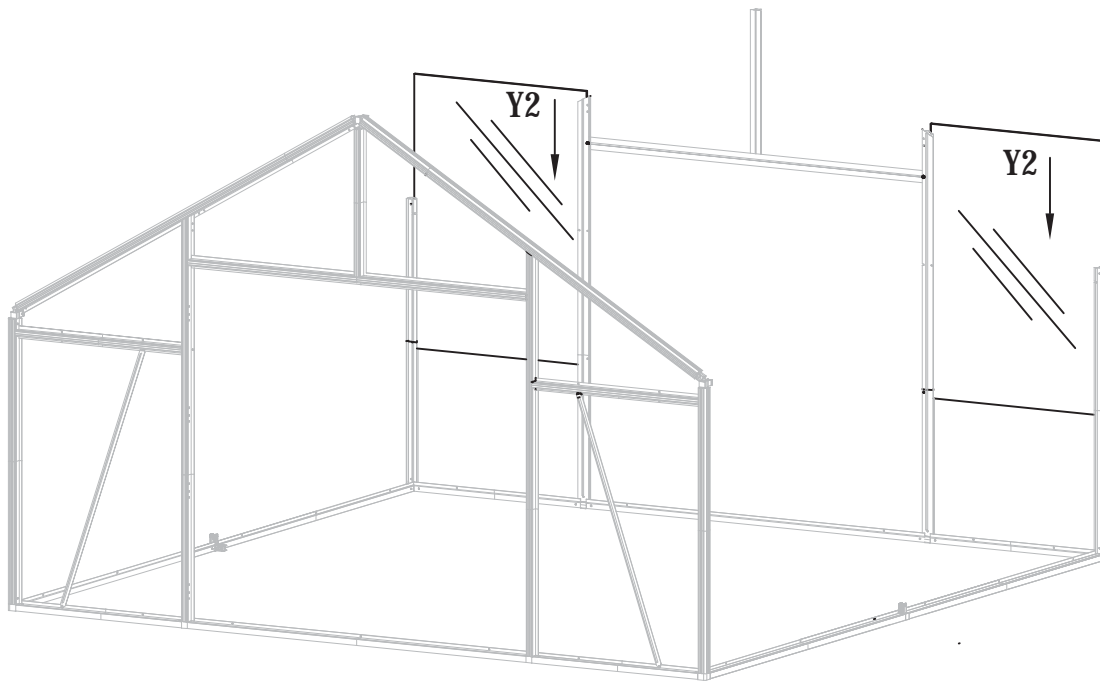



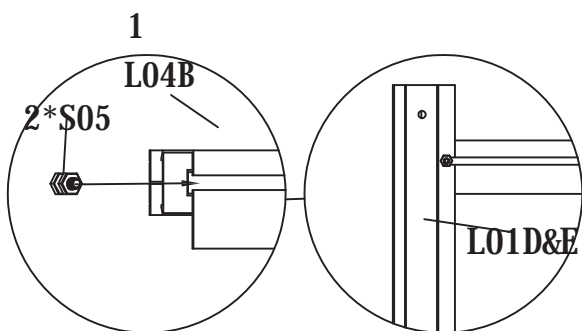
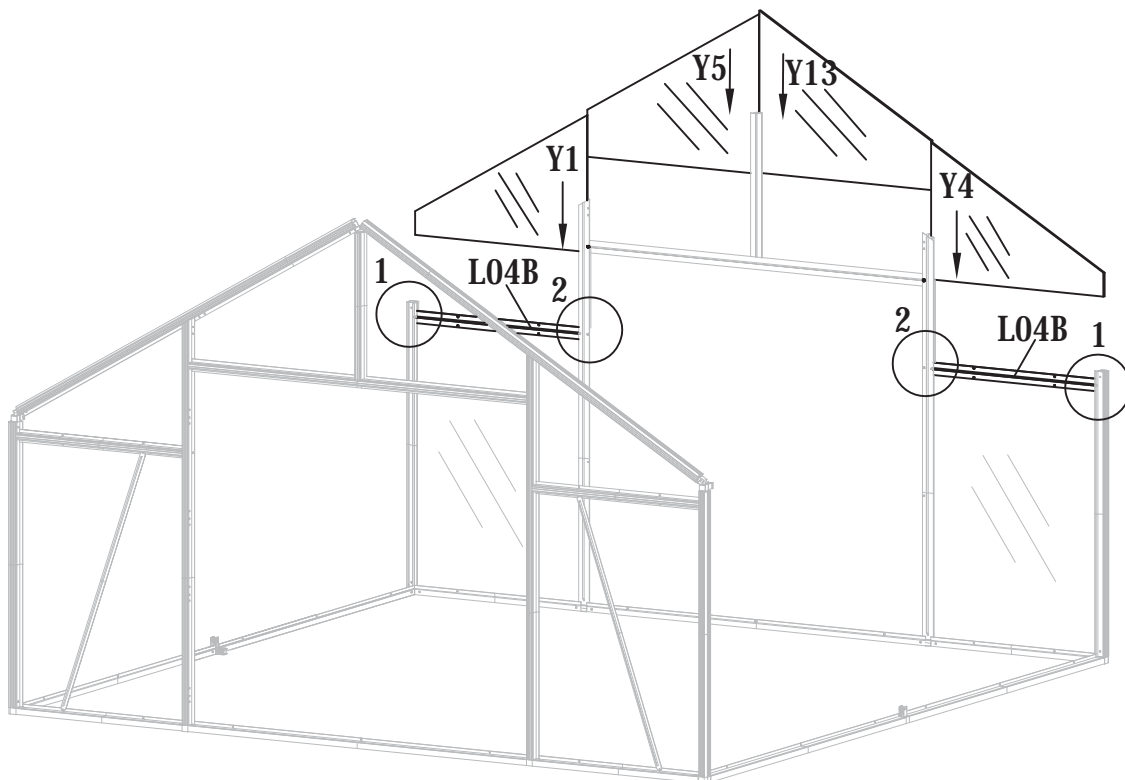



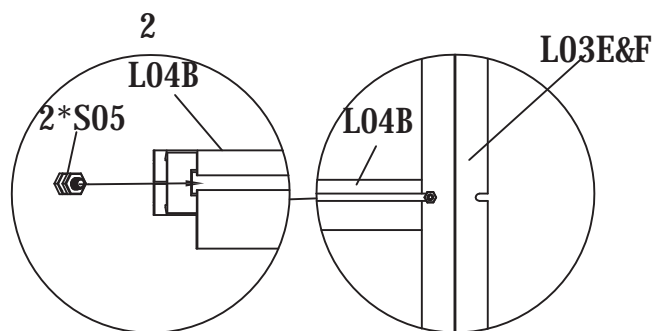



PART	NO.	QTY.
	Y1	1
	Y2	2
	Y4	1
	Y5	1
	Y13	1
	L04B	2
	S05	4
	M6X12	
	M03	4
	M6	



Slide 2\*S05 into L04B, and tighten L04B at each end with S05



Slide 2\*S05 into L04B, and tighten L04B at each end with S05

PART	NO.	QTY.
	L01B	1
	L01C	1
	L05A	2
	A09	1
	A10	1
	A11	1
	D17	3
	S05	17
	M6X12	
	M03	17
	M6	



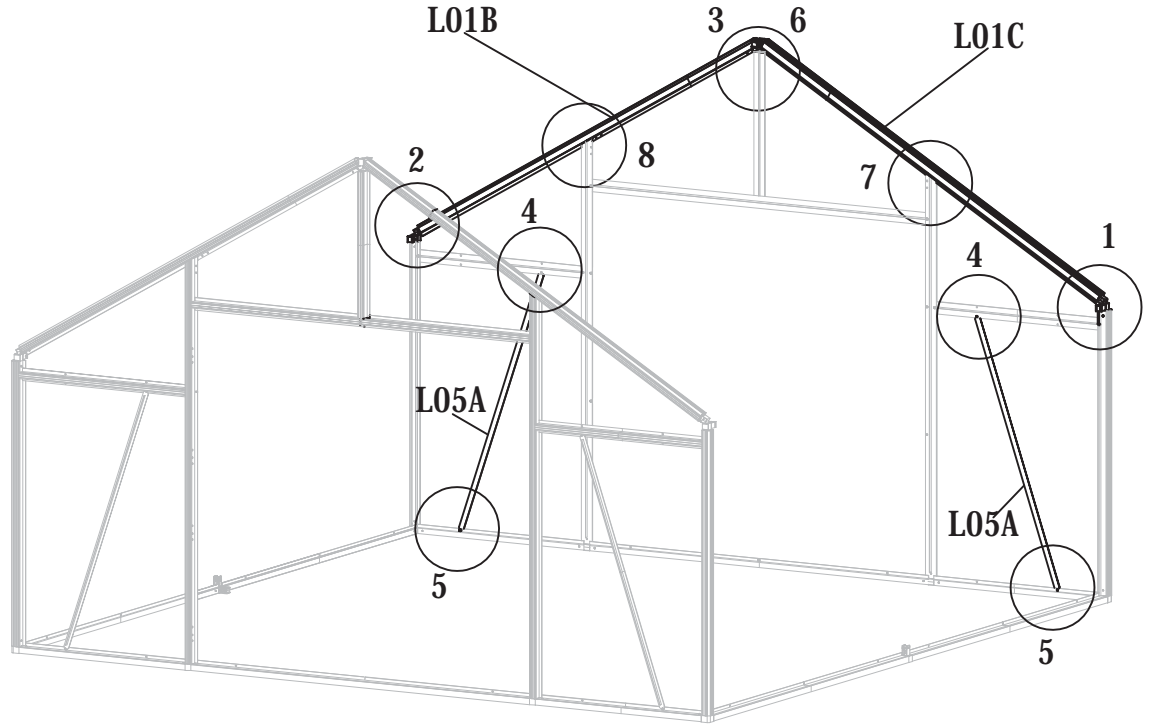

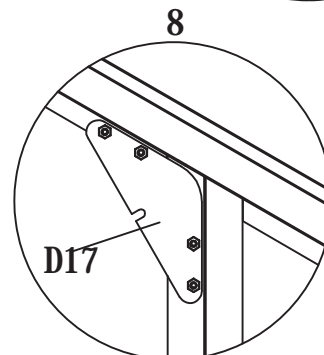
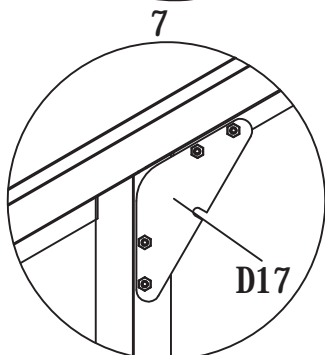
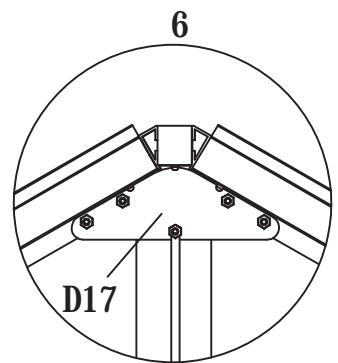
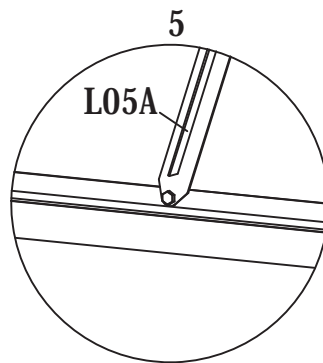
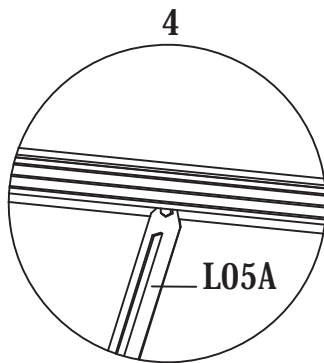
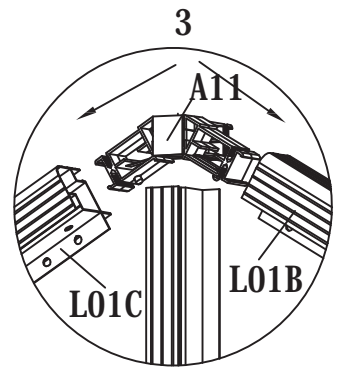
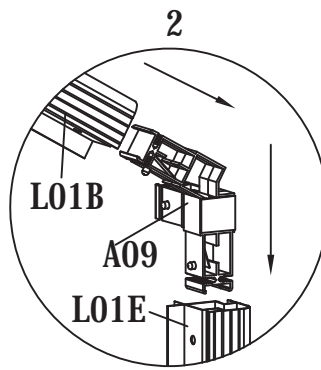
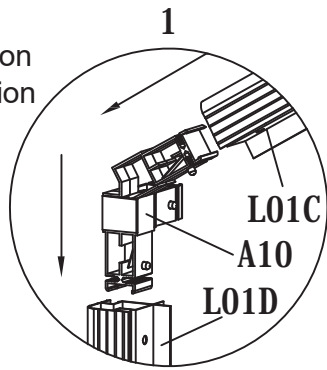

Note: please insert upper roof supports but, do not lock in place until you have aligned the polycarbonate inserts.



make sure you pay close attention to the direction of the pins







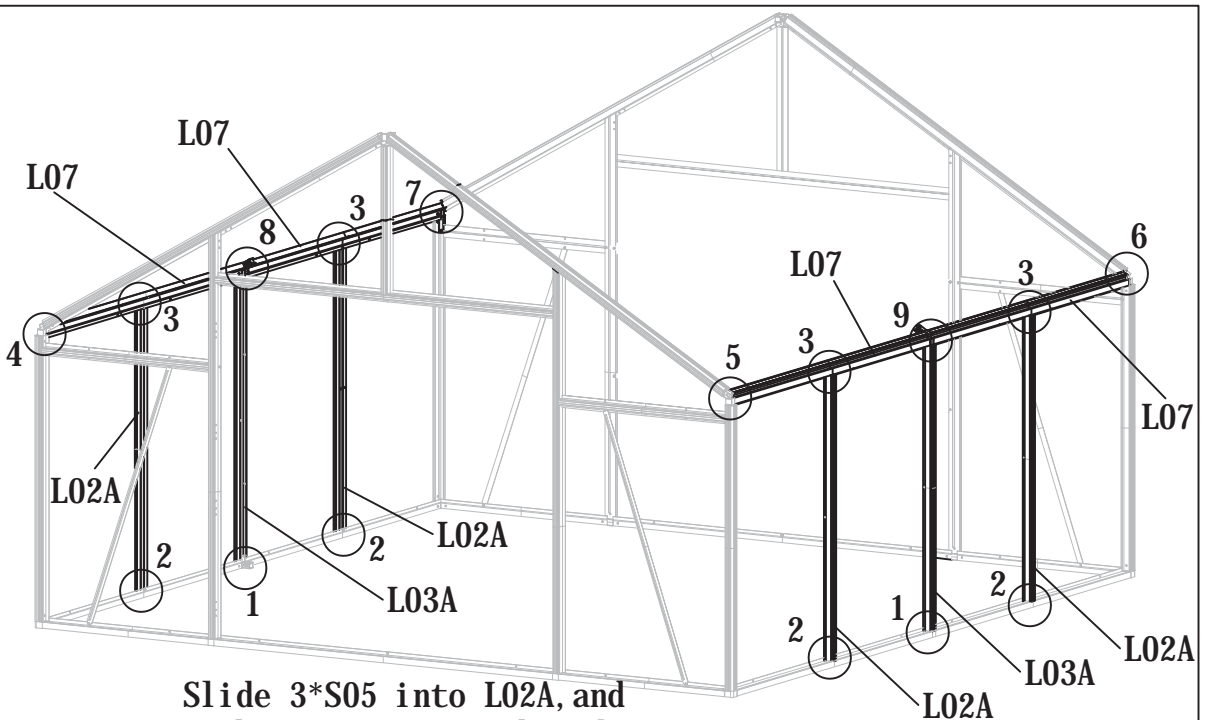

PART	NO.	QTY.
	L02A	4
	L03A	2
	L07	4
	A12	2
	S05	12
	M6X12	
	M03	12
	M6	

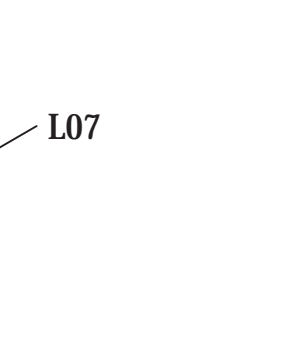
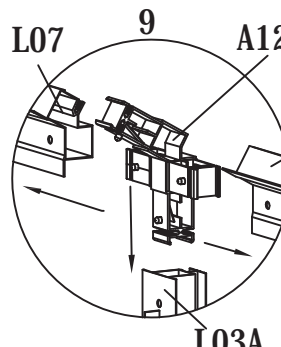
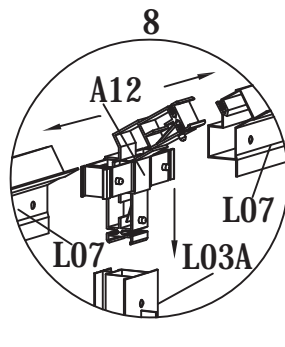
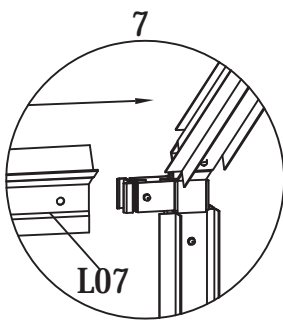
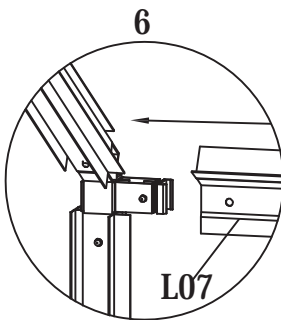
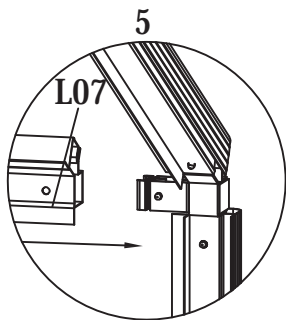
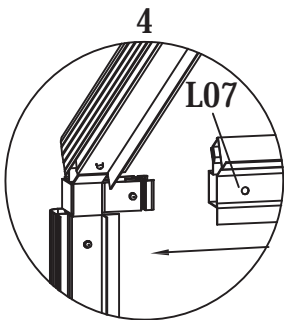
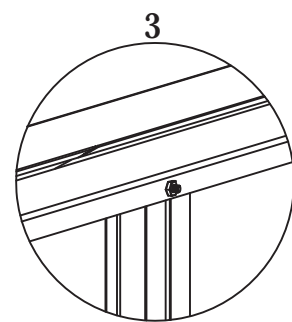
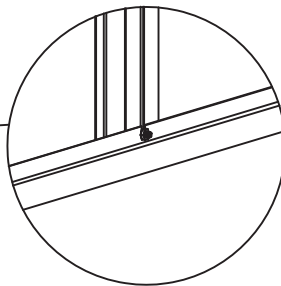
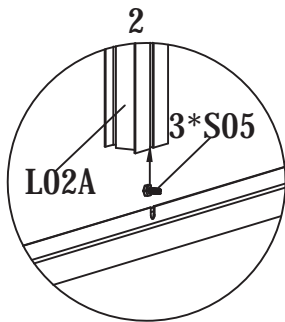
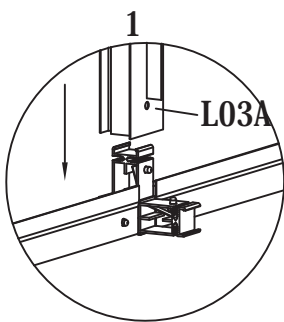

Slide 3\*S05 into L02A, and tighten L02A at each end with S05







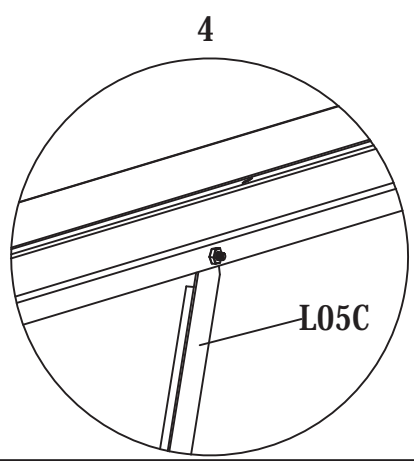
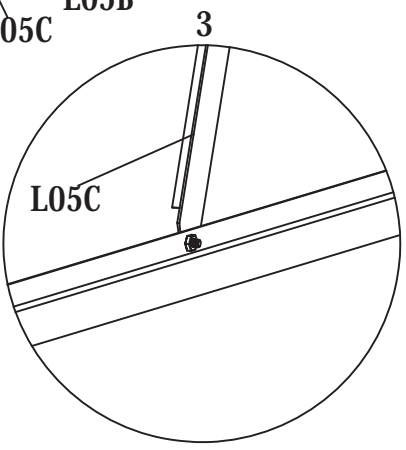
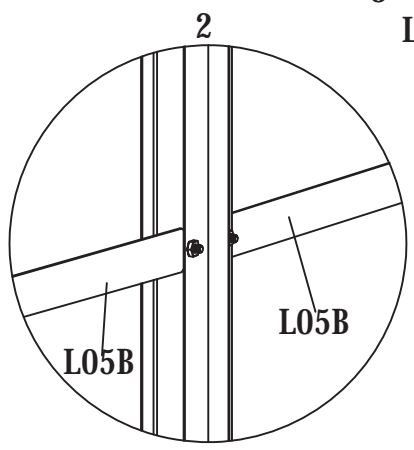
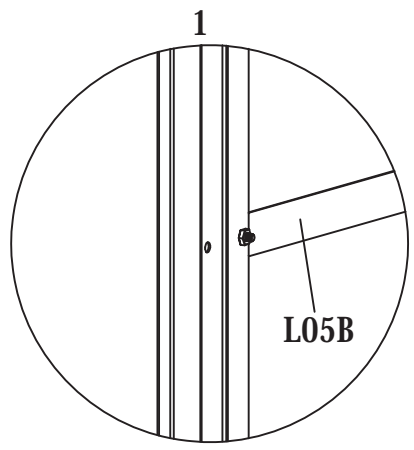
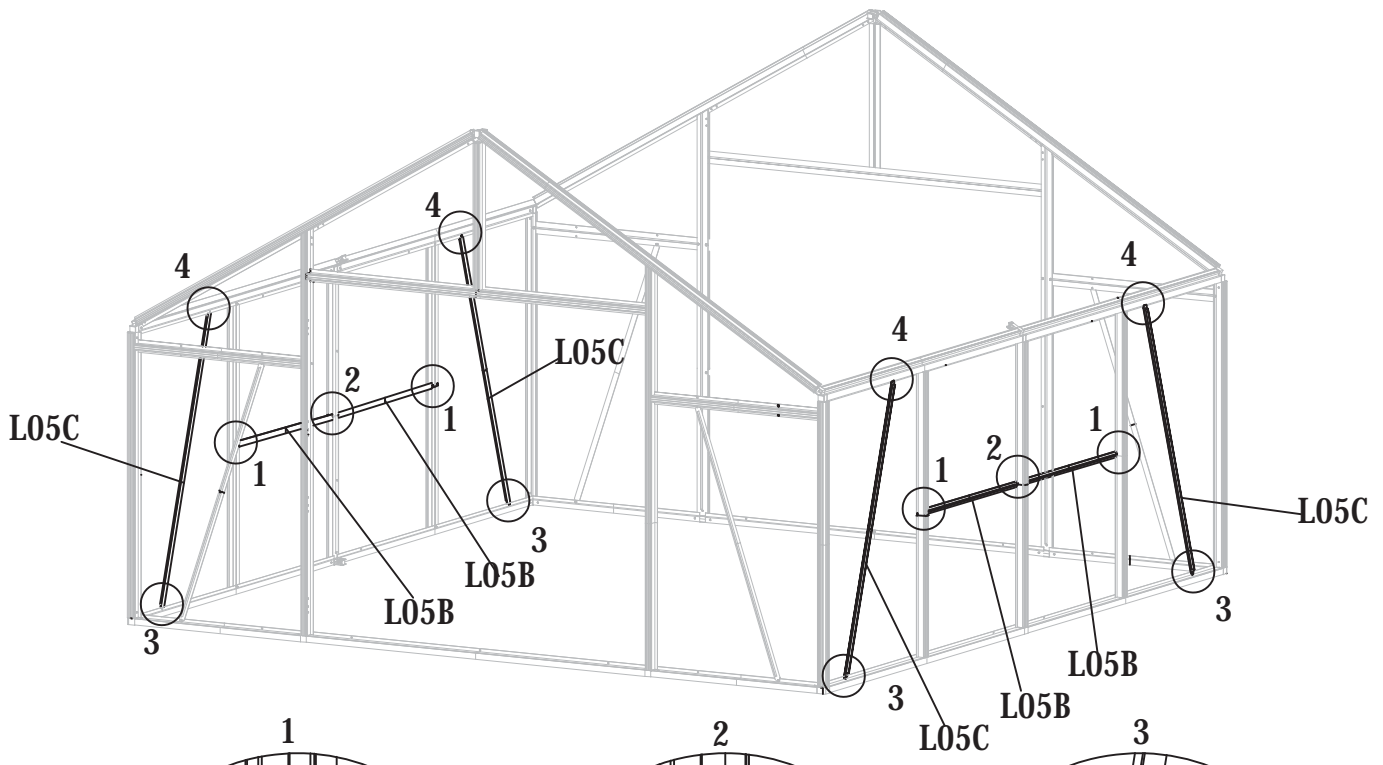

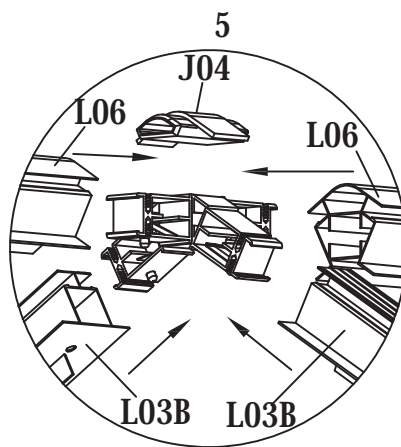
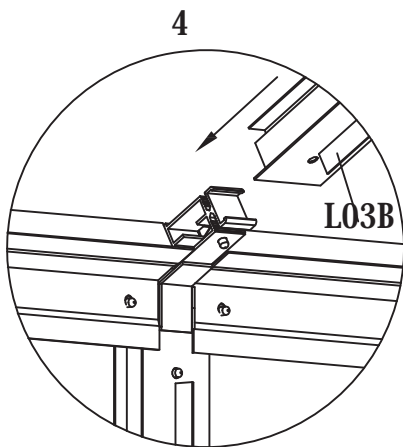
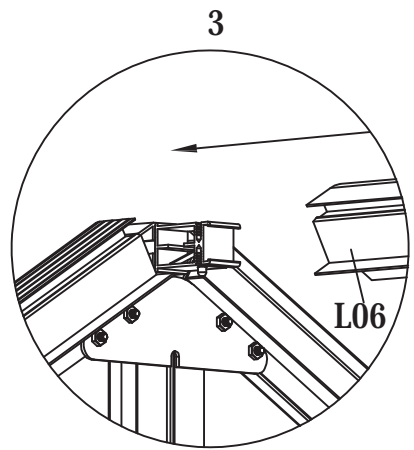
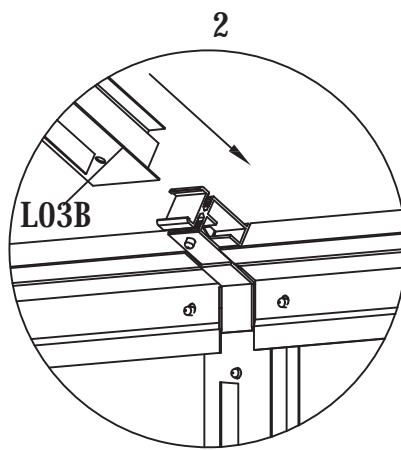
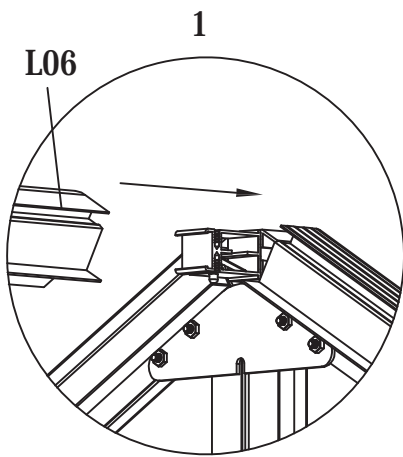
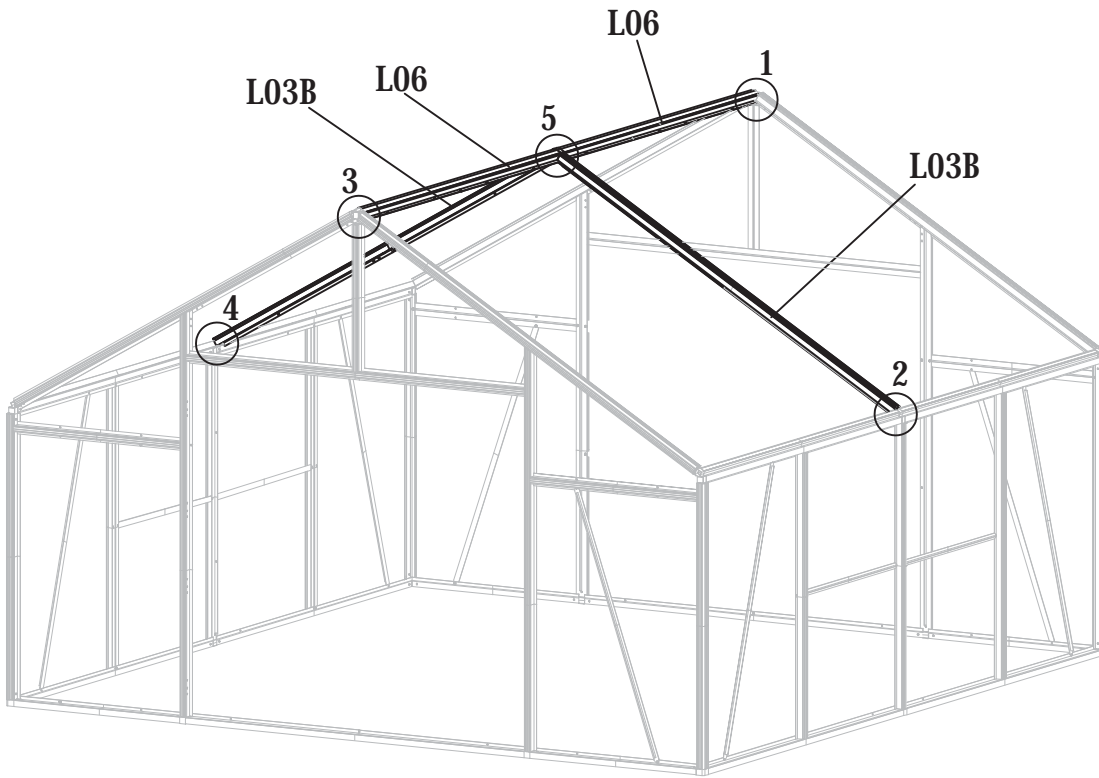



PART	NO.	QTY.
	L05B	4
	L05C	4
	S05	16
	M6X12	
	M03	16
	M6	







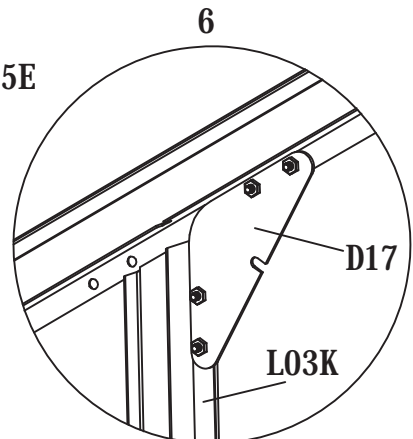
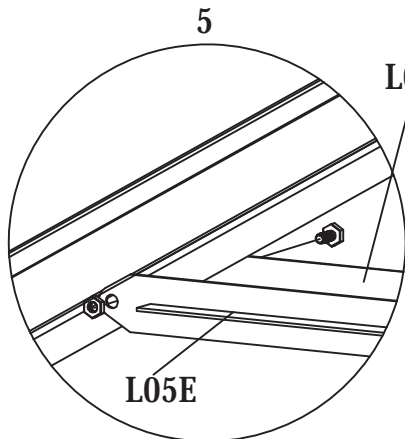
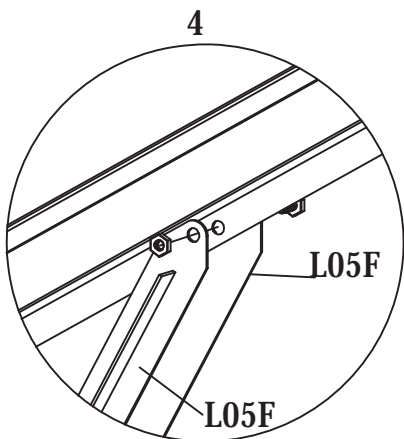
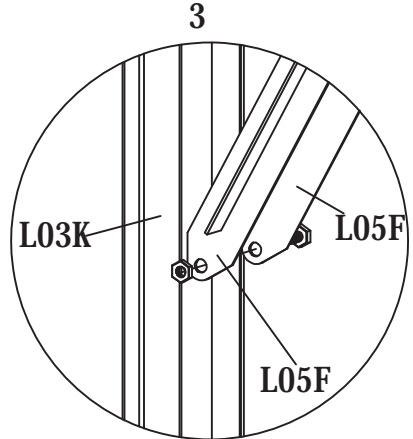
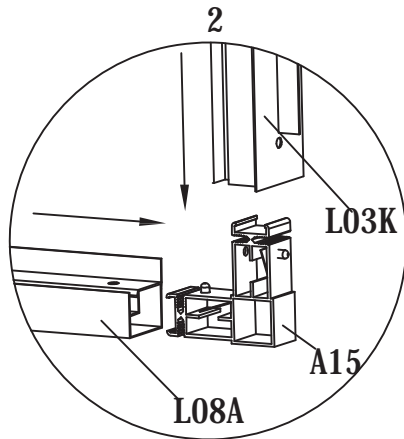
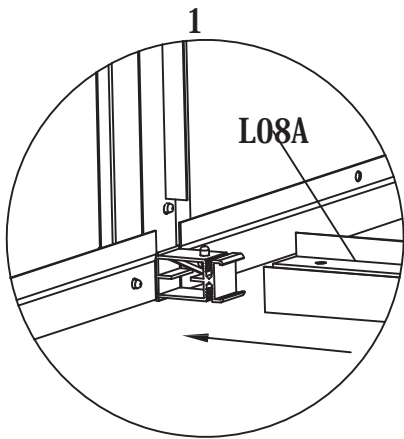
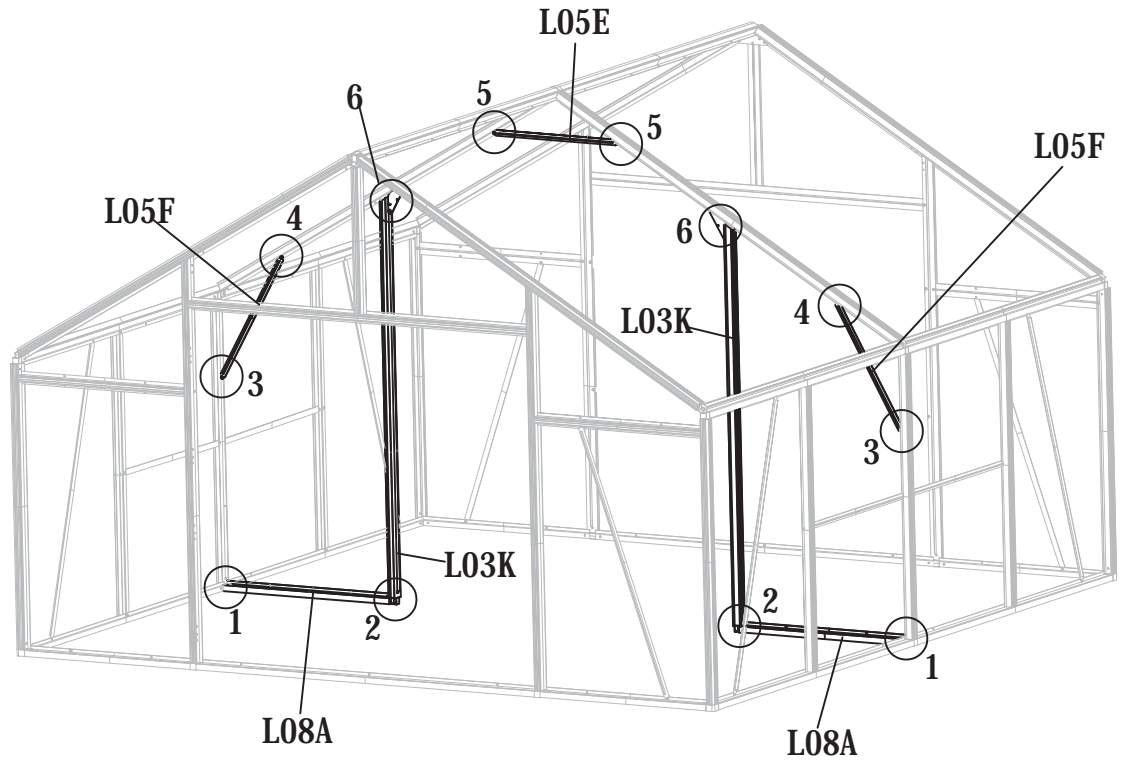

PART	NO.	QTY.
	L03B	2
	L06	2
	A13	1
	D17	2
	J04	1
	S05	8
	M6X12	
	M03	8
	M6	

PART	NO.	QTY.
	L03K	2
	L05E	2
	L05F	4
	L08A	2
	A15	2
	D17	2
	S05	14
	M6X12	
	M03	14
	M6	



PART	NO.	QTY.
	L02B	4
	L22	6
	S05	16
	M6X12	
	M03	16
	M6	

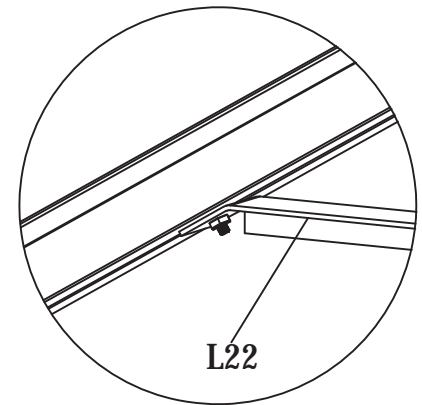
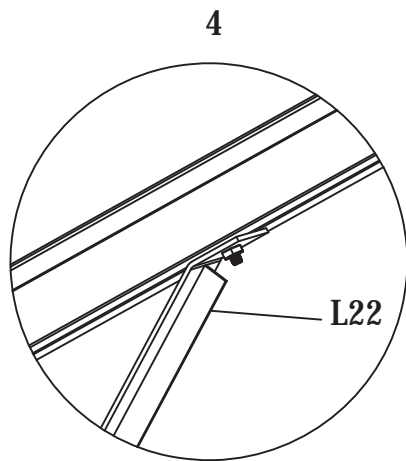
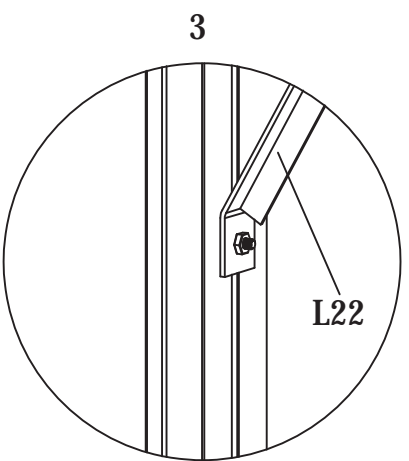
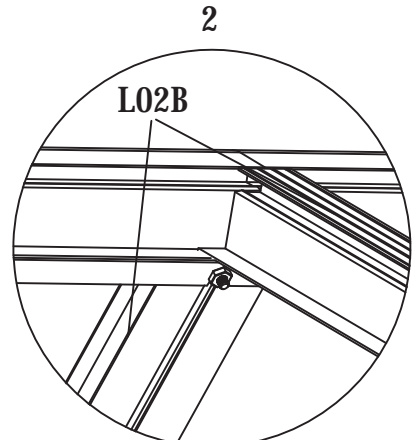
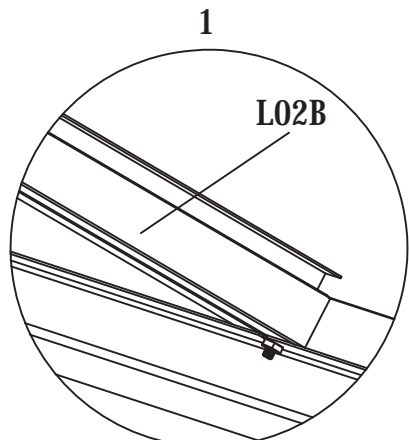
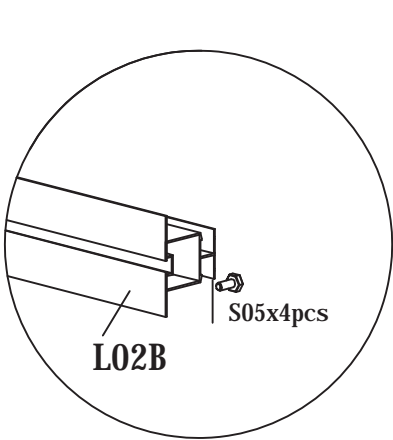
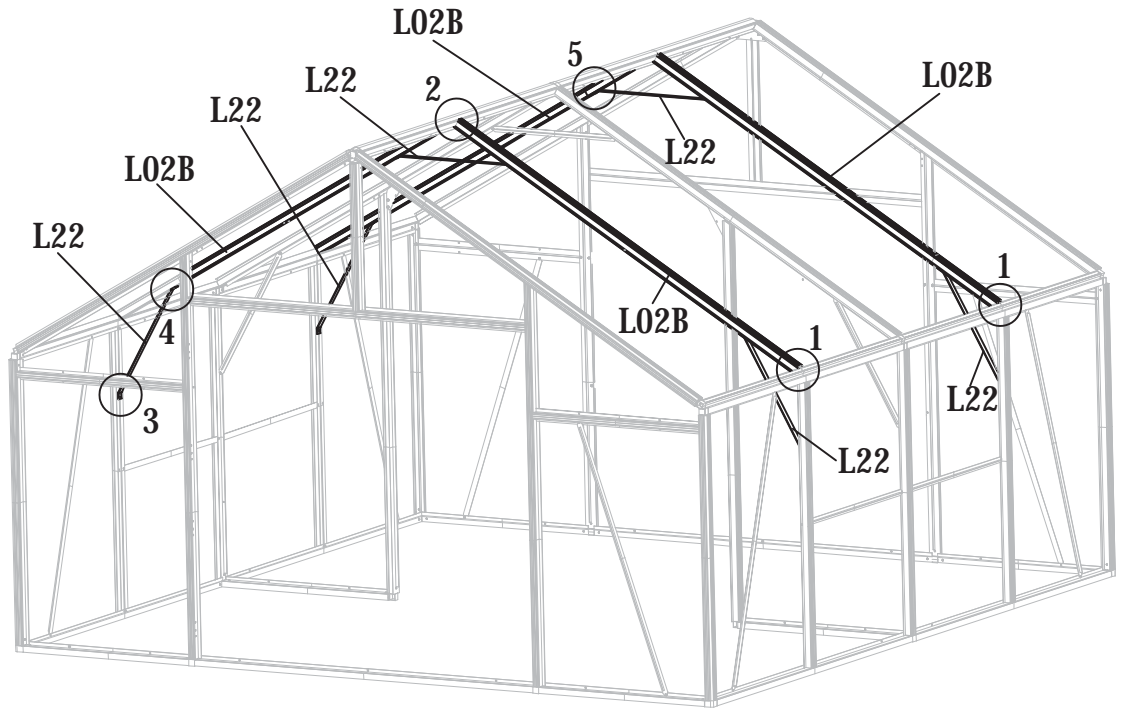

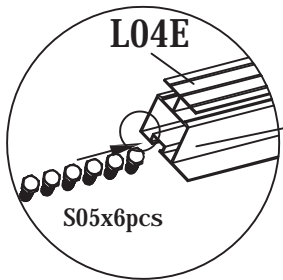
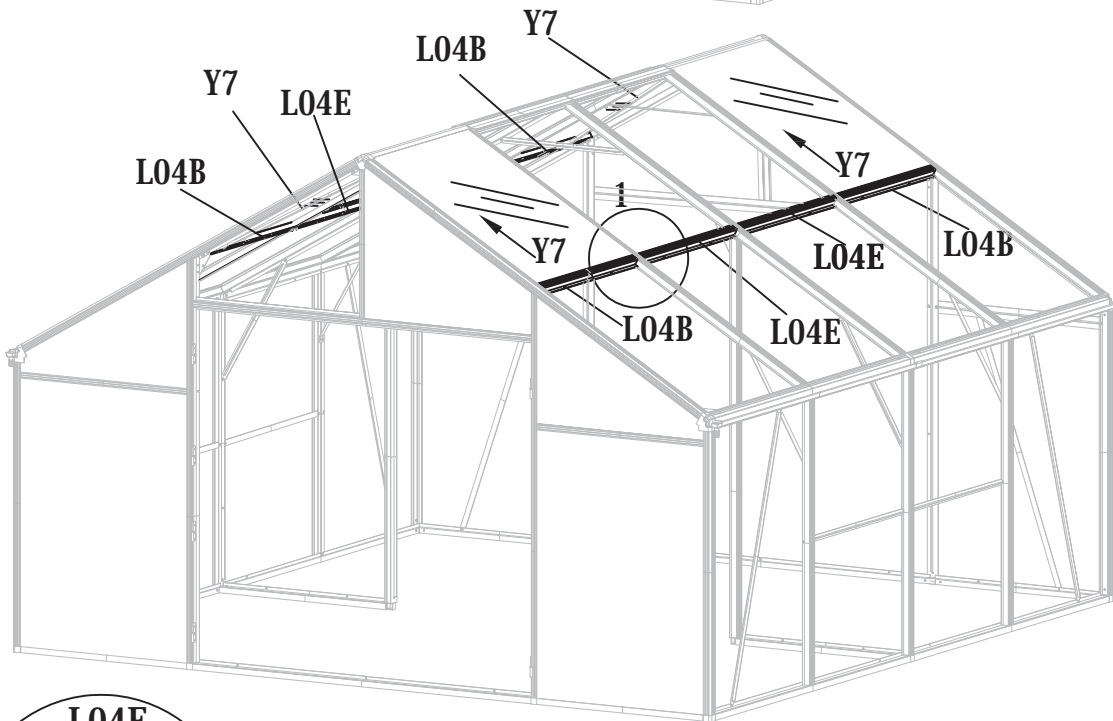
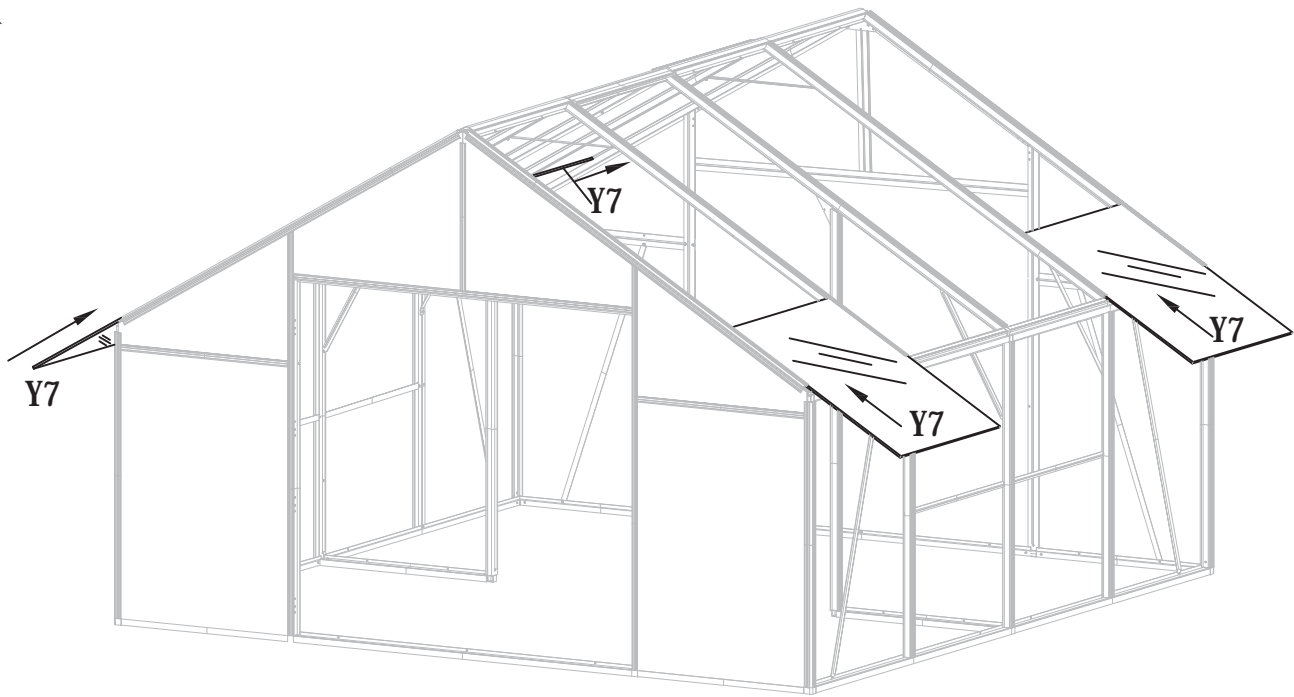



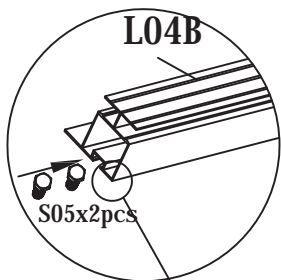



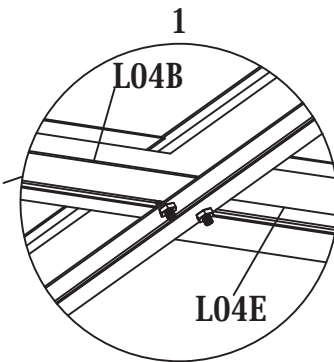





Pay attention to the cut edge of L04E which should be fixed, facing up.



Pay attention to the cut edge of L04B which should be fixed, facing down.



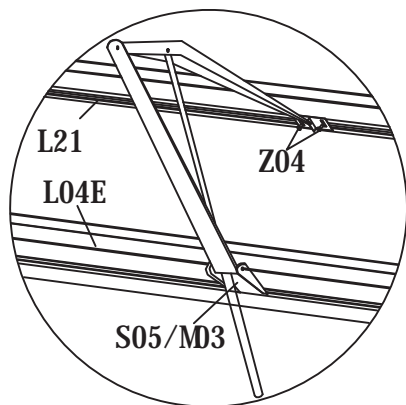
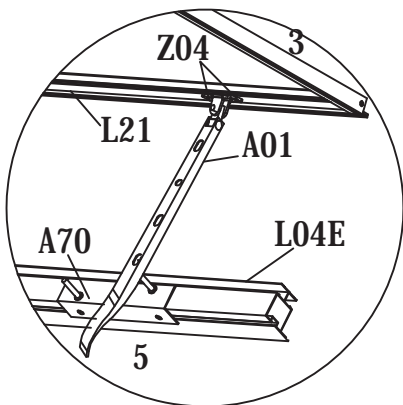
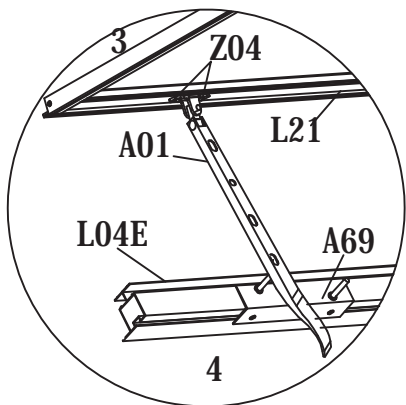
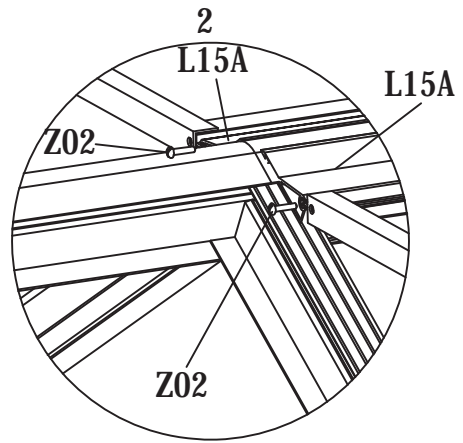
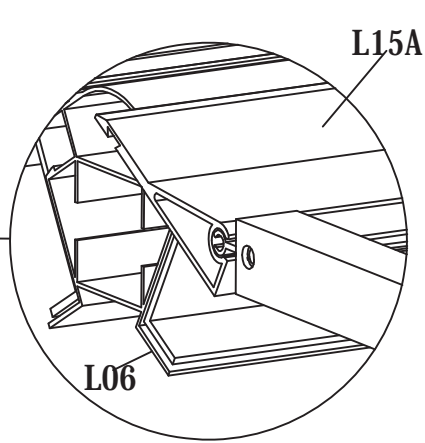
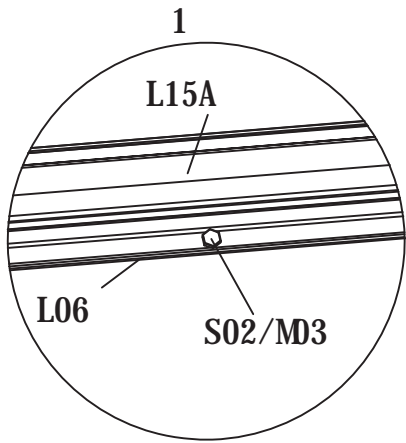
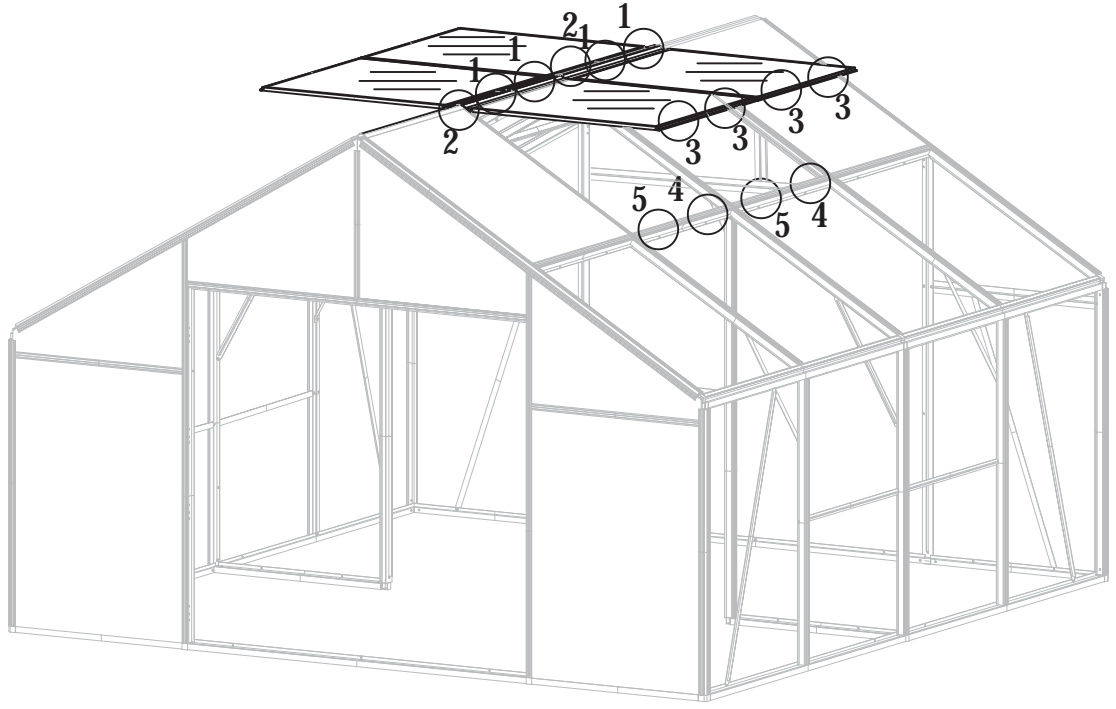

PART	NO.	QTY.
	L04B	4
	L04E	4
	Y7	4
	S05	32
	M6X12	
	M03	32
	M6	

PART	NO.	QTY.
	Roof Vent	4
	A01	8
	A69	4
	A70	4
	Z04	16
	Ø4X8	
	S11	8
	M6X20	
	M03	24
	M6	





PART	NO.	QTY.
	Y7	8
	Y6	8

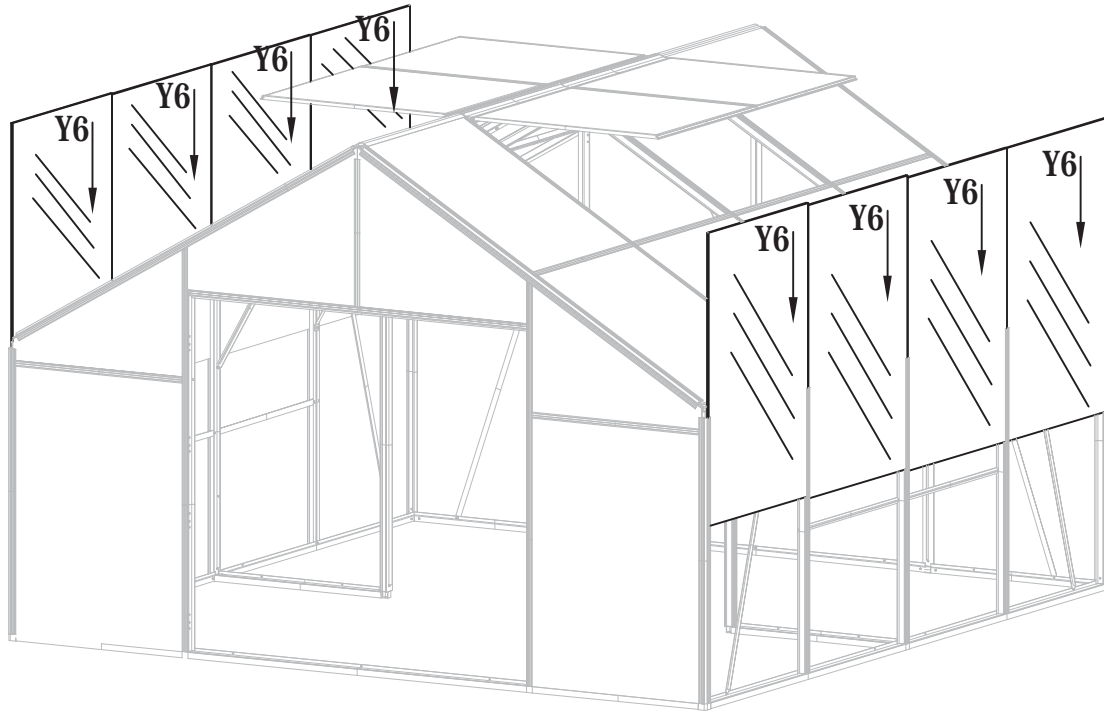
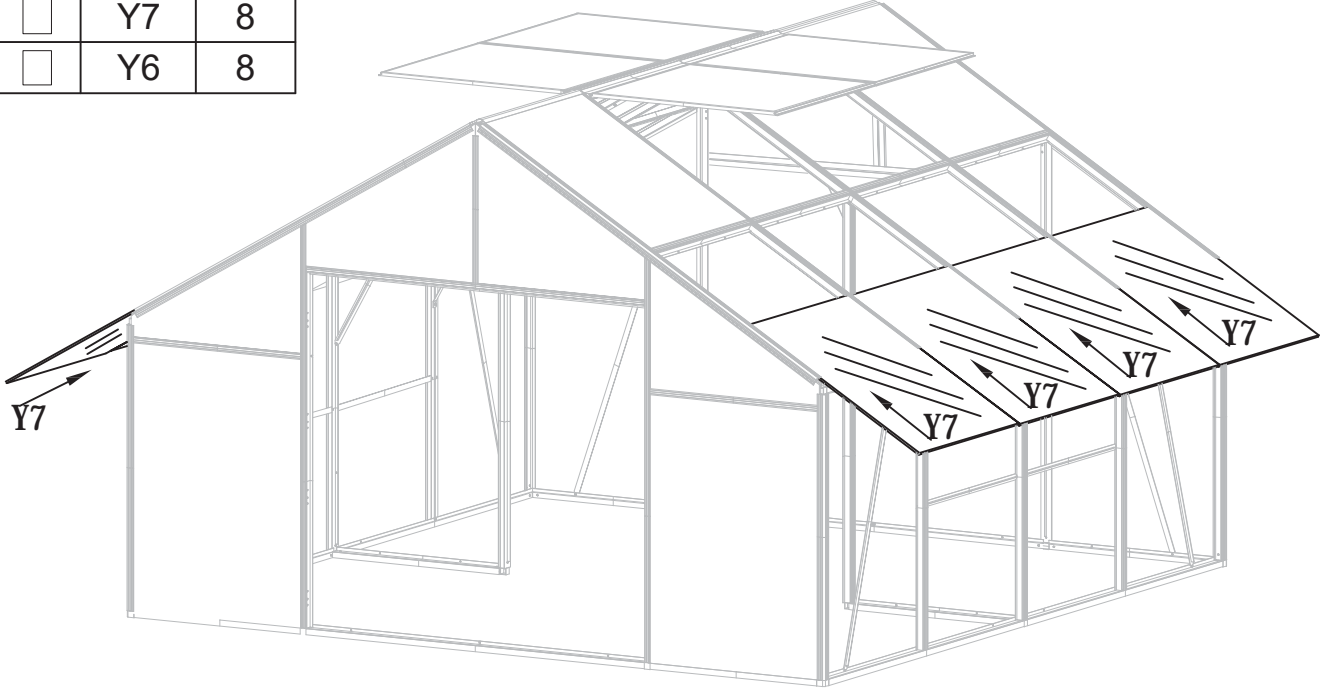

PART	NO.	QTY.
	L09	4
	J07	2
	J02	2
	J06R/L	2/2
	L30	4
	J92	4
	J93	4
	Z10	16
	Ø5X30	
	Z02	16
	Ø4X16D	

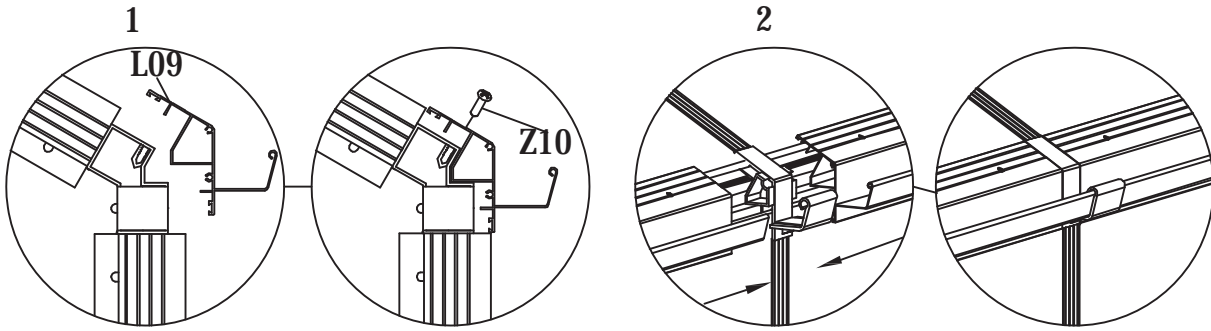
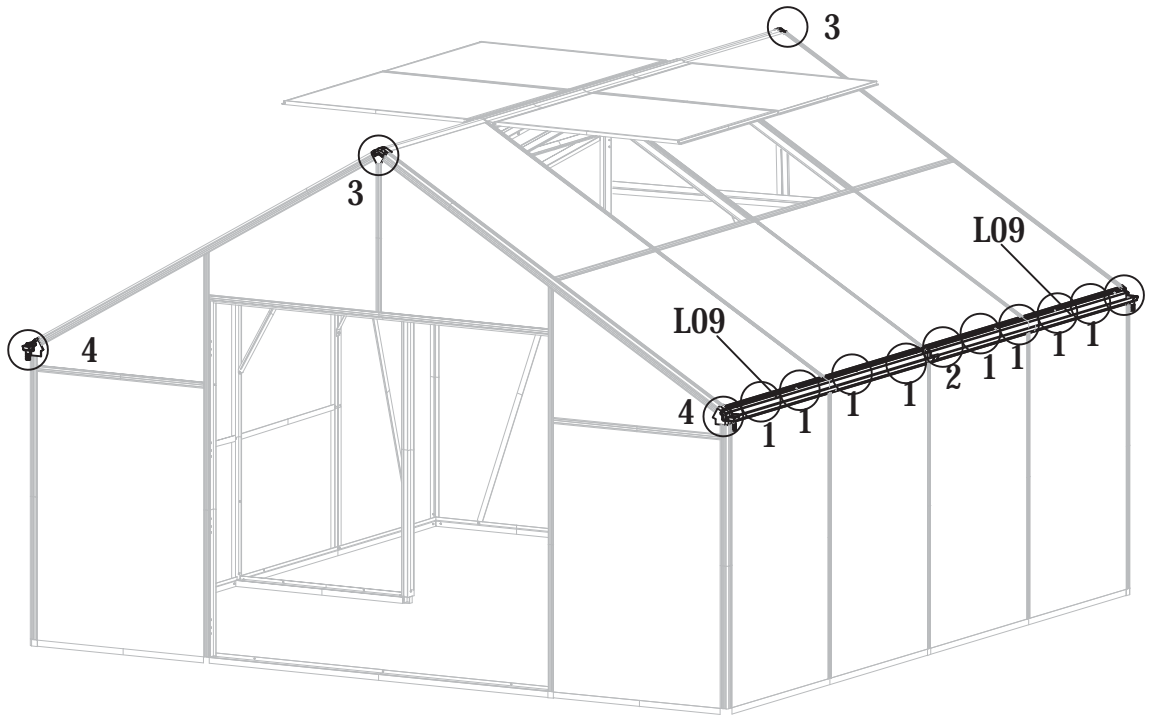

Use L09 to cover the edges of all Y9 after all roof PC panels are fixed in place, then tighten them with Z10.

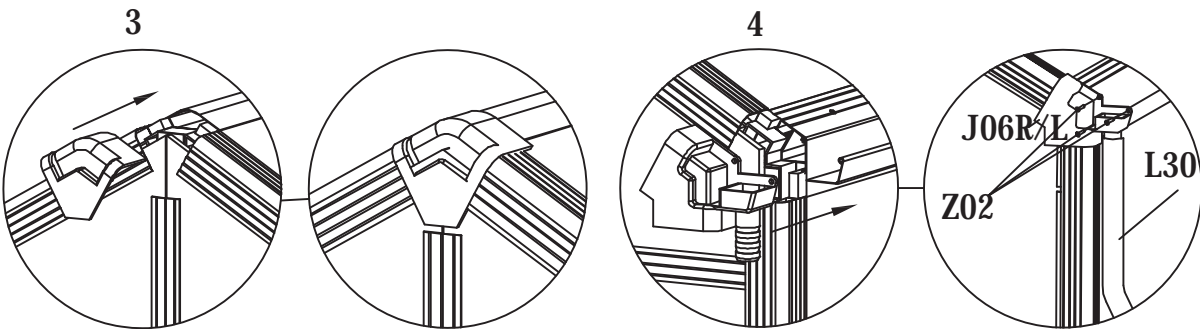

Drill one hole on both L01A & L01D & L01E approx 500mm up from the bottom, Dia. 2.5mm, then tighten J92 with Z02, and push L30 into the channel of J92 (see Fig. above).

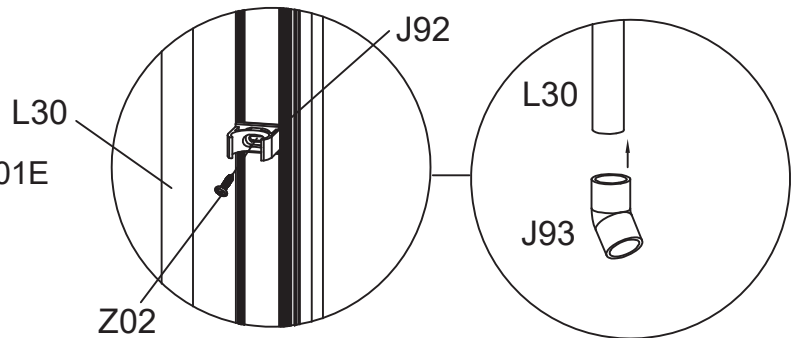

To avoid leaking, using silicone on J02R / L, L30 and J93 is an option (see Fig. above).

REPEAT the same assembly for the other side.



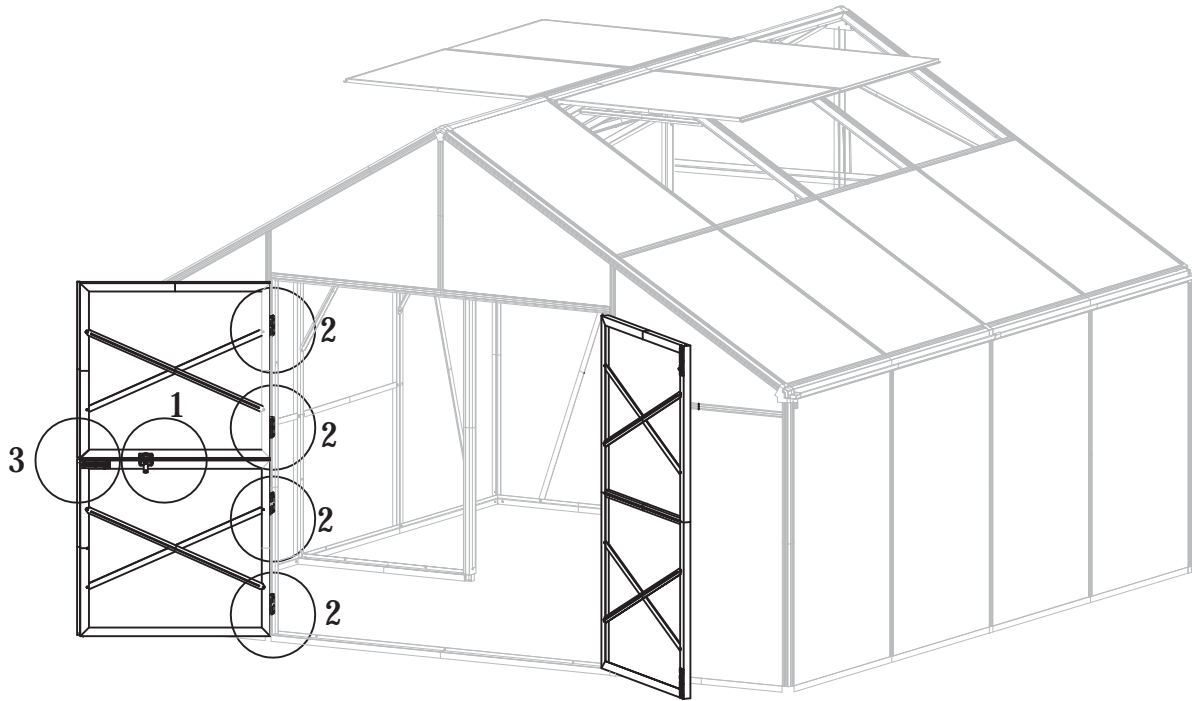





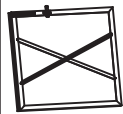
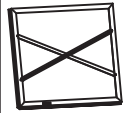

To install the doors, simply slide the hinge pins on the doors into the corresponding hinge sleeves on the greenhouse. The latch shown in image 1 joins the two sections of the doors together.

To make minor height adjustments you can remove or add the spacers provided on the pin section of the hinge.

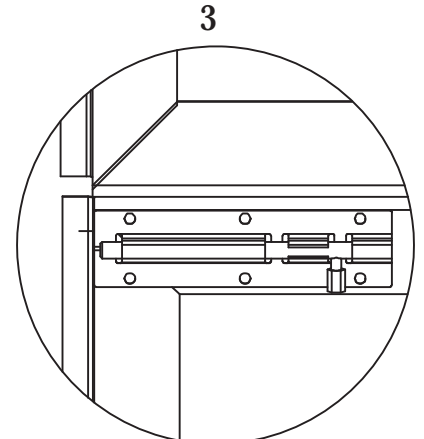
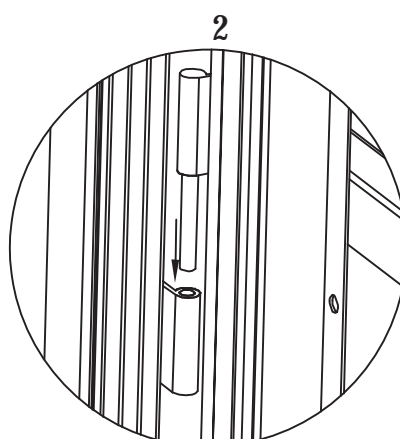
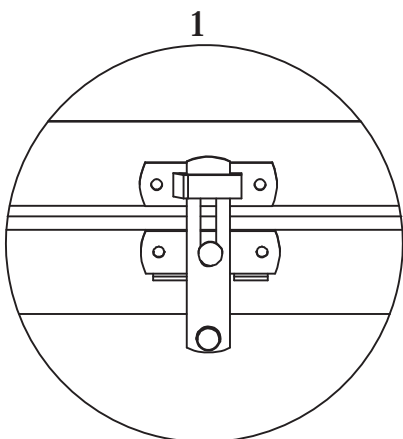
You can also adjust the squareness of the doors by loosening the diagonal braces, then holding pressure in the direction you may want to adjust the door and then tighten the braces.

PART	NO.	QTY.
	Door 1	1
	Door 2	1
	Door 3	1



PART	NO.	QTY.
	L05D	4
	S05	8
	M6X12	
	M03	8
	M6	

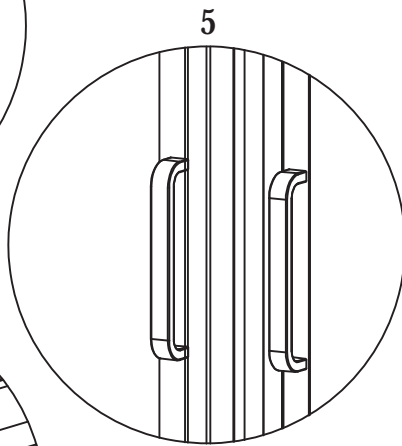
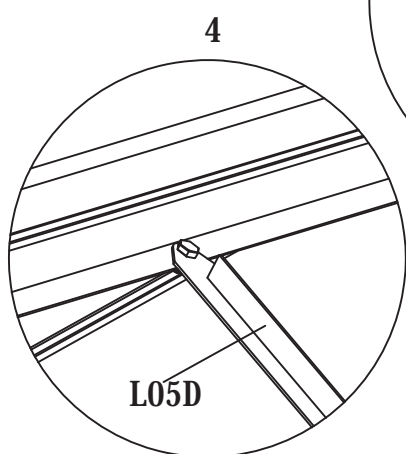
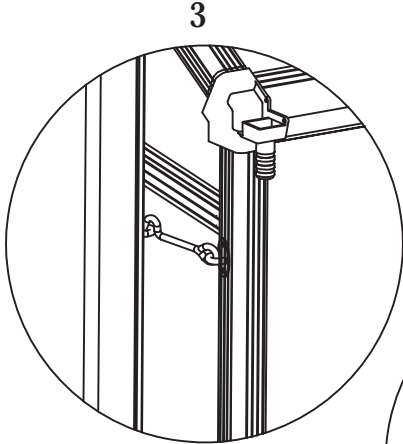
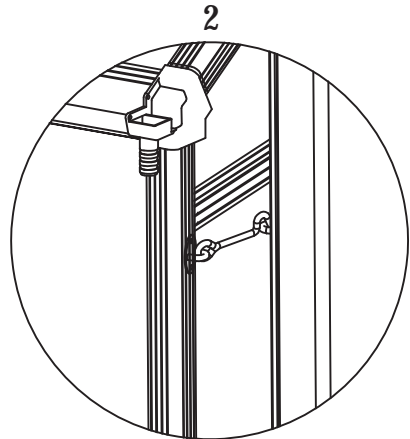
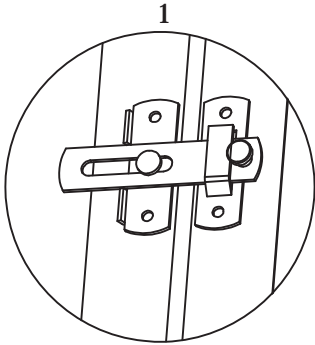
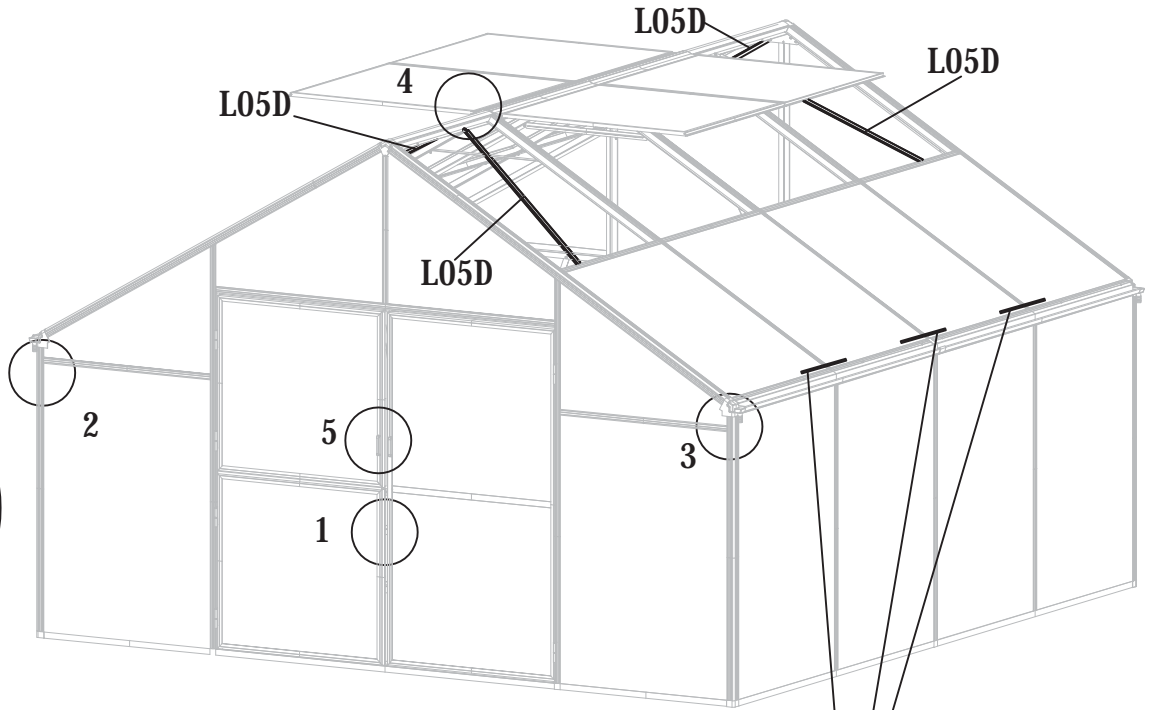

Once the L09 is in place.  
A small bead of silicon suitable for polycarbonate can assist in preventing leaks.

